

Mating behaviour, spermatophore structure,
ecology and systematics of the
Cicindela splendida group
(Coleoptera: Cicindelidae)

by

Larry Aldo Schincariol ©

A thesis
presented in partial fulfillment of the requirements
for the degree of Master of Science

Department of Biology
Lakehead University
Thunder Bay, Ontario

1988

©

ProQuest Number: 10611781

All rights reserved

INFORMATION TO ALL USERS

The quality of this reproduction is dependent upon the quality of the copy submitted.

In the unlikely event that the author did not send a complete manuscript and there are missing pages, these will be noted. Also, if material had to be removed, a note will indicate the deletion.



ProQuest 10611781

Published by ProQuest LLC (2017). Copyright of the Dissertation is held by the Author.

All rights reserved.

This work is protected against unauthorized copying under Title 17, United States Code
Microform Edition © ProQuest LLC.

ProQuest LLC.
789 East Eisenhower Parkway
P.O. Box 1346
Ann Arbor, MI 48106 - 1346

Permission has been granted to the National Library of Canada to microfilm this thesis and to lend or sell copies of the film.

The author (copyright owner) has reserved other publication rights, and neither the thesis nor extensive extracts from it may be printed or otherwise reproduced without his/her written permission.

L'autorisation a été accordée à la Bibliothèque nationale du Canada de microfilmer cette thèse et de prêter ou de vendre des exemplaires du film.

L'auteur (titulaire du droit d'auteur) se réserve les autres droits de publication; ni la thèse ni de longs extraits de celle-ci ne doivent être imprimés ou autrement reproduits sans son autorisation écrite.

ISBN 0-315-48193-5

ABSTRACT

Observations of copulating pairs of conspecific and interspecific individuals of *Cicindela splendida* Hentz and *Cicindela limbalis* Klug revealed behaviour similar to that previously described for *Pseudoxychila tarsalis* Bates, and for five species of *Cicindela* including *C. limbalis*.

Differences in behaviour of both species studied here compared to previous studies included: absence of a distinct phase 3 in copulation; ejection of the spermatophore by the female immediately after the aedeagus was withdrawn; repeated copulation with increased intercopulatory intervals and smaller spermatophores; and contact guarding by the male during time spans ranging from 6 to 10 hours in length.

The spermatophore consisted of a two-chambered capsule, the outer surface of both being rippled and cratered. The smaller capsule, referred to here as the lateral capsule, contained a mass of sperm cells and other cellular material. Although the lumen of the large capsule appeared empty in examination the presence of a few suspended cells suggested that it was probably fluid filled. The rapid transfer of the spermatophore and the details of its complex structure suggested that the male carried a pre-made spermatophore which probably formed within a field of spines and was moulded around one of the sclerites of the internal sac.

The life cycle of *C. limbalis* in Thunder Bay was

shown to last for approximately three years, a finding consistent with life cycle studies of other tiger beetles from this region and with studies of *C. limbalis* in Manitoba. The prolongation of the larval life of *C. limbalis* over a second winter in the northern part of its distribution is probably caused by shorter summers which limit total food intake and delay progress through the larval stages.

Collection dates of adults indicated that members of the *C. splendida* group (*C. splendida*, *C. limbalis* and *C. denverensis*) are spring-fall species, and northern populations emerged later during spring than southern populations. Despite the differences in time of peak abundance, the three species overlapped in time and space, thus excluding these factors as species isolating mechanisms.

Male and female genitalia of the three studied species were very similar. Those of *C. splendida* and *C. limbalis* were more similar to each other than to *C. denverensis*. Mating experiments between *C. splendida* and *C. limbalis* suggested that mechanical isolation due to genitalic incompatibility was not present between these species, but the ability of the female to eject a spermatophore may represent a post-copulatory isolating mechanism which serves to maintain species integrity. The absence of large numbers of hybrids of these three species, suggested that although closely related, they can be distinguished from each other, and should retain their rank as species, until further

investigations can prove that they are not reproductively isolated.

Comparison of geographical distribution of these species with that of dominant soil types revealed that all three had similar soil preferences. Specimens of *C. splendida* and *C. limbalis* occurred more frequently with each other than with those of *C. denverensis*. However, the geographical distribution of all three species was smaller than the range of their preferred soil types, probably because of the same factors that influence their local distributions.

Numerical analyses of morphometric data of these species revealed a closer similarity between *C. splendida* and *C. limbalis*. In both sexes, elytral pattern, percentage maculation, elytral colour and non-sensory setae number, collectively, distinguish these species from each other whereas body measurements, body ratios, sensory setae and labral setae, collectively, fail to distinguish them.

The ancestor of this species group probably evolved during the later stages of the Tertiary Period as a North American resident and was a continental, riparian, cool-temperate form that ranged across Canada and the northeastern and central United States. Extant forms speciated during the late Pleistocene Epoch as a result of isolation and adaptation during glacial and interglacial periods. During the first glaciation *C. denverensis* became

isolated in the southwest. The species *C. splendida* became isolated in the southeast United States in the foothills of the Appalachian Mountains during the second glaciation and subsequent to the ice retreat, spread westward across the Mississippi Valley. The remaining portion of the ancestral group returned northward following the ice retreat and spread across Canada from east to west, forming the species *C. limbalis*. The elytral pattern, percentage maculation, elytral colour and non-sensory setae number of these species corresponds to their adaptations to differing climatic and geographic factors.

ACKNOWLEDGEMENTS

I wish to express my sincere appreciation to my supervisor, Dr. R. Freitag for his advice and encouragement during this study; the members of my committee, Dr. K. Deacon, Dr. G.W. Ozburn and my external examiner, Dr. G.E. Ball; and the curators of the insect collections for their co-operation, consideration and patience.

Thanks are also extended to A. MacKenzie for technical assistance with electron microscopy; to Dr. P.F. Lee and Dr. R.L. Counts for advice on statistical procedures; to L. Hauta for assistance with computing; to C.E. Garton for identifying study site vegetation; to G. Hashiguchi for assistance with photo-reduction of thesis figures, maps and photographs; to D.W. Brzoska and M. Carter for collecting and shipping live specimens; and to W.N. Johnson and N.L. Rump for sharing their unpublished data.

Special thanks to my family, especially my sister D.L. Pugh, for assistance in field work, sorting and labeling borrowed specimens, typing, proofreading, and aiding in preparation of the transcript including figures, maps and photographs.

Financial support for this study was provided by NSERC grant A 4888 to Dr. R. Freitag, and by an Ontario Graduate Scholarship.

TABLE OF CONTENTS

TITLE PAGE	1
DECLARATION	3
ABSTRACT	4
ACKNOWLEDGEMENTS	8
TABLE OF CONTENTS	9
LIST OF TABLES	11
LIST OF FIGURES	13
PART A: Mating Behaviour and Spermatophore Structure	17
INTRODUCTION	18
MATERIALS AND METHODS	19
Field Methods and Laboratory Conditions	19
Copulating Phases and Mating Behaviour in <i>Cicindela limbalis</i> and <i>Cicindela splendida</i>	20
Spermatophore and Sperm Cell of <i>Cicindela splendida</i>	21
RESULTS AND DISCUSSION	26
Copulating Phases and Mating Behaviour in <i>Cicindela limbalis</i> and <i>Cicindela splendida</i>	26
Spermatophore and Sperm Cell of <i>Cicindela splendida</i>	30
Mechanism of Spermatophore Formation and Transfer	33
PART B: Ecology and Systematics	44
INTRODUCTION	45
Taxonomic History	47

MATERIALS AND METHODS	52
Adult Specimens and Loaning Institutions	52
Characters and Measurements	58
Population Samples	61
Numerical Analyses of Morphometric Data	80
Study Sites	82
Life Cycle	84
Field Methods and Specimen Preservation	85
Laboratory Conditions and Rearing Techniques	86
Genitalia of the <i>Cicindela splendida</i> Group	88
Soil Associations	89
Seasonality and Distribution	89
Criteria for Species and Subspecies	90
RESULTS AND DISCUSSION	91
Eggs and Larvae of <i>Cicindela limbalis</i>	91
Life Cycle	92
Genitalia of the <i>Cicindela splendida</i> Group	114
Soil Associations	134
Numerical Analyses of Morphometric Data	146
Elytral Colour and Maculations	162
Classification	164
Distribution	175
Evolution and Zoogeography	206
Recommendations for Additional Research	213
LITERATURE CITED	219

LIST OF TABLES

Table		Page
1	Designated states for colour of dorsal surface of elytra of <i>C. splendida</i> , <i>C. limbalis</i> , and <i>C. denverensis</i> .	76
2	Population samples (n) of <i>C. splendida</i> (6), <i>C. limbalis</i> (15), and <i>C. denverensis</i> (3) used in numerical and colour analyses.	77
3	Ratio of males to females captured in the two study sites during the two field seasons.	103
4	Relative frequency (%) and absolute frequency (in brackets) of occurrence of locality records of <i>C. limbalis</i> on dominant soil types as indicated by soil maps (see text for references of soil maps).	143
5	Relative frequency (%) and absolute frequency (in brackets) of occurrence of locality records of <i>C. splendida</i> on dominant soil types as indicated by soil maps (see text for references of soil maps).	144
6	Relative frequency (%) and absolute frequency (in brackets) of occurrence of locality records of <i>C. denverensis</i> on dominant soil types as indicated by soil maps (see text for references of soil maps).	145
7	Percentage of variance explained by factors used in the factor analysis of males.	152
8	Rotated factor matrix for males.	153
9	Standardized canonical discriminant function coefficients for males using all factors.	154
10	Classification results of male discriminant analysis using all factors.	154
11	Standardized canonical discriminant function coefficients for males using factors 2 and 3 only.	155
12	Classification results of male discriminant analysis using factors 2 and 3 only.	155

13	Standardized canonical discriminant function coefficients for males excluding factors 2 and 3.	156
14	Classification results of male discriminant analysis excluding factors 2 and 3.	156
15	Percentage of variance explained by factors used in the factor analysis of females.	157
16	Rotated factor matrix for females.	158
17	Standardized canonical discriminant function coefficients for females using all factors.	159
18	Classification results of female discriminant analysis using all factors.	159
19	Standardized canonical discriminant function coefficients for females using factors 2 and 3 only.	160
20	Classification results of female discriminant analysis using factors 2 and 3 only.	160
21	Standardized canonical discriminant function coefficients for females excluding factors 2 and 3.	161
22	Classification results of female discriminant analysis excluding factors 2 and 3.	161

LIST OF FIGURES

Figure		Page
1	Photomicrograph of united male and female genitalia illustrating the internal sac (InS) everted into the bursa copulatrix (BCx) and a spermatophore (Sph) between them.	36
2	Scanning electron micrograph of the large capsule (LgC) and the lateral capsule (LtC) of the spermatophore.	36
3	Scanning electron micrograph of the rippled and cratered surface of the spermatophore.	36
4	Photomicrograph of a section through the spermatophore illustrating the layers of material which form the large capsule (LgC) with its irregularly shaped lumen (Lu) and the lateral capsule (LtC), as well as the sperm mass (SM) within the lateral capsule.	36
5	Photomicrograph of sperm mass (SM) within the lateral capsule taken with Nomarski phase contrast.	36
6-7	Transmission electron micrographs illustrating the random orientation and density of sperm within the lateral capsule of the spermatophore.	36
8	Transmission electron micrograph of a section through the lateral capsule of the spermatophore showing various cellular components.	36
9-11	Transmission electron micrographs of a layer of tissue found embedded within the spermatophore, illustrating many large mitochondria (M), the "cytoplasm" which contains ribosome-studded cisterne of the endoplasmic reticulum (RER) and embedded sperm tails (ST).	38
12-13	Transmission electron micrograph of bacteria embedded in the lateral capsule.	38
14-16	Transmission electron micrographs of sperm cells as seen by means of negative staining.	38
17	Transmission electron micrograph of sperm cells as seen by means of negative staining.	40
18-19	Scanning electron micrographs of the more prevalent sperm form which has an enlarged head	

	diameter tapering to a moderately long thinner tail diameter.	40
20-22	Scanning electron micrographs of the less prevalent sperm form which appears to be very long with the head diameter only slightly larger than the tail diameter.	40
23	Transmission electron micrograph of a longitudinal section through a sperm tail, illustrating the axoneme (Ax) and the two adjacent mitochondrial nebenkerns (MN).	40
24	Transmission electron micrograph of a section through a sperm head and core of the tail.	40
25-26	Transmission electron micrographs of a cross section of a sperm tail illustrating the axoneme with its 9+9+2 pattern of accessory tubules (AT), doublets (D) and central tubules (CT).	42
27	Transmission electron micrograph of a cross section of a sperm tail illustrating the axoneme (Ax) of 9+9+2 microtubules, the accessory body (AB) alongside the axoneme, the two mitochondrial nebenkerns (MN) and the core (C).	42
28	Transmission electron micrograph of a cross section of several sperm tails which are cut at different regions along their length.	42
29-30	Transmission electron micrograph of a cross section of a possible aberrant sperm cell with two tails bound by a membrane.	42
31	Head of adult <i>C. limbalis</i> , frontal aspect.	62
32	Labrum of adult <i>C. limbalis</i> , frontal aspect.	62
33	First three segments of left antenna of adult <i>C. limbalis</i> .	62
34	Pronotum of adult <i>C. limbalis</i> .	64
35	Left mesothoracic leg of <i>C. limbalis</i> , frontal aspect.	64
36	Adult elytra of <i>C. limbalis</i> , dorsal aspect.	66
37	Percent of elytral surface covered by light maculations.	68

38	Humeral lunule character states.	70
39	Middle band character states.	72
40	Apical lunule character states.	74
41	Population samples (n) used in numerical and colour analyses of <i>C. splendida</i> (6), <i>C. limbalis</i> (15) and <i>C. denverensis</i> (3).	78
42	Life cycle of <i>C. limbalis</i> compared with those of other species of <i>Cicindela</i> .	101
43-44	Total catch of <i>C. limbalis</i> at the Kaministiquia River site during the 1984 and 1985 field seasons.	104
45-46	Total catch of <i>C. limbalis</i> at the Rosslyn Brick Yard site during the 1984 and 1985 field seasons.	106
47	Collection dates of adult specimens of <i>C. limbalis</i> .	108
48	Collection dates of adult specimens of <i>C. splendida</i> .	110
49	Collection dates of adult specimens of <i>C. denverensis</i> .	112
50-53	Aedeagus, ventral and left lateral aspects, and sclerites of the internal sac of <i>C. splendida</i> from Hope, Arkansas (Fig. 50), Asheville, North Carolina (Fig. 51), Osceola, Nebraska (Fig. 52) and Mount Vernon, Virginia (Fig. 53).	116
54-57	Aedeagus, ventral and left lateral aspects, and sclerites of the internal sac of <i>C. limbalis</i> from Osceola, Nebraska (Fig. 54), Greenwood Lake, New Jersey (Fig. 55), Norman Wells, Northwest Territories (Fig. 56) and Thunder Bay, Ontario (Fig. 57).	118
58-61	Aedeagus, ventral and left lateral aspects, and sclerites of the internal sac of <i>C. denverensis</i> from Denver, Colorado (Fig. 58), Dunn County, North Dakota (Fig. 59), Benkelman, Nebraska (Fig. 60) and Lawrence, Kansas (Fig. 61).	120
62-63	Female genitalia of <i>C. splendida</i> from Hope, Arkansas (Fig. 62) and Asheville, North Carolina (Fig. 63).	122

64-65	Female genitalia of <i>C. splendida</i> from Osceola, Nebraska (Fig. 64) and Mount Vernon, Virginia (Fig. 65).	124
66-67	Female genitalia of <i>C. limbalis</i> from Osceola, Nebraska (Fig. 66) and Greenwood Lake, New Jersey (Fig. 67).	126
68-69	Female genitalia of <i>C. limbalis</i> from Norman Wells, Northwest Territories (Fig. 68) and Thunder Bay, Ontario (Fig. 69).	128
70-71	Female genitalia of <i>C. denverensis</i> from Denver, Colorado (Fig. 70) and Dunn County, North Dakota (Fig. 71).	130
72-73	Female genitalia of <i>C. denverensis</i> from Benkelman, Nebraska (Fig. 72) and Lawrence, Kansas (Fig. 73).	132
74	Distribution of <i>C. limbalis</i> , <i>C. splendida</i> and <i>C. denverensis</i> .	204
75	Phylogeny of the <i>C. splendida</i> group.	215
76	Distribution of the ancestral form of the <i>C. splendida</i> group.	217
77	The position of the maximum late Wisconsinan ice mass and the distribution of the ancestral form with a portion becoming <i>C. denverensis</i> .	217
78	The position of the retreating ice mass, the isolated population of <i>C. denverensis</i> , and the distribution of the ancestral form with a portion becoming <i>C. splendida</i> .	217
79	The position of the retreating ice mass and the distribution of <i>C. denverensis</i> , <i>C. splendida</i> and the most recent form, <i>C. limbalis</i> .	217

Part A

Mating Behaviour
and
Spermatophore Structure

INTRODUCTION

Mating behaviour of tiger beetles was reported by Palmer (1976) and Freitag et al. (1980). These studies described the stereotypic mating behaviour of conspecific pairs of tiger beetles and how this behaviour was related to the formation and transfer of a spermatophore. Schincariol (1984) and Schincariol and Freitag (1986) described how the mating behaviour of *Cicindela* was governed by the coupling mechanism of the flagellum and spermatheca duct and proposed a mechanism for transfer of semen and sperm. The mating behaviour of interspecific pairs of closely related species of tiger beetles has not been studied previously.

The method of formation, structure, function and mechanism of transfer of insect spermatophores of various insect orders has been reviewed by Davey (1965), Wigglesworth (1972), Chapman (1982), and Thornhill and Alcock (1983). Freitag (1966) described the size and shape of spermatophores found in the female tiger beetle *C. flavopunctata* Chevrolat, and proposed a possible mechanism for the transfer of semen and sperm and the formation of the spermatophore.

The biology of insect spermatozoa has been reviewed by Davey (1965), Nath (1965), Baccetti (1970, 1972) and Baccetti and Afzelius (1976). Nath et al. (1957) described the spermatogenesis of four species of Indian *Cicindela* (*C. nitida* Wiedemann, *C. erudita* Wiedemann, *C. albina* Wiedemann, and *C. vigintiguttata* Herbst). These authors conducted

comprehensive studies of fixed and living material using phase-contrast microscopy. Nath et al. (1960) defended their work on *Cicindela* and Werner (1965) described spermatogenesis in the tiger beetle *C. campestris* Linnaeus, as revealed by transmission electron microscopy.

The main objectives of this study were: (1) to describe mating behaviour, as observed in the laboratory, of conspecific and interspecific pairs of *Cicindela splendida* Hentz and *Cicindela limbalis* Klug; (2) to describe the structure of a tiger beetle spermatophore and sperm cell; and (3) to review the mechanism of spermatophore formation and transfer proposed by Freitag (1966).

MATERIALS AND METHODS

Field Methods and Laboratory Conditions

Adult specimens of *C. limbalis* were captured by insect net near Thunder Bay, Ontario during May, June and July 1985. Living specimens were brought back to the laboratory and the sexes separated into plexiglass terraria each measuring 75 x 50 x 30 cm. Each terrarium was covered with a wire screen and contained a petri dish of water. Small pieces of crumpled paper served as cover. Adult specimens of *C. splendida* and *C. limbalis* collected at Douglas County, Kansas in March 1985 and at Osceola, Nebraska in May 1985 were also kept in the laboratory. Photoperiod was simulated with the use of fluorescent room lights which

were on during the day and off at night, plus 3000 watts incandescent light which went on and off periodically during the 12 hour day cycle as controlled by appliance timers. A 250 watt infra red lamp provided heat. Room temperature was maintained between 22°C to 28°C with a relative humidity of approximately 65%. The tiger beetles were fed mainly on *Tribolium* sp. supplemented with other arthropods from sweep-netting and small earthworms.

Copulating Phases and Mating Behaviour in *Cicindela limbalis* and *Cicindela splendida*

An investigation of the mating sequences of stereotypic behaviour as described by Palmer (1976), Freitag et al. (1980) and Schincariol (1984) was conducted in the laboratory. Conspecific or interspecific males and females of *C. limbalis* and *C. splendida* were placed in a clear plastic jar 8 cm in diameter by 6 cm deep and allowed to mate. All combinations of males and females of each species were placed together, including those collected in the same area as well as those collected from different provinces or states. Copulating phases and mating behaviour were noted and timed with a stop watch. Spermatophores ejected by the female upon completion of mating were preserved and prepared for morphological examination as described in the following section.

Copulating pairs of *C. limbalis* were frozen in

liquid nitrogen during the latter part of phase 2 and early phase 3 to determine the origin of the spermatophore. The frozen mated pairs with genitalia presumed to be united were thawed and dissected as described by Schincariol and Freitag (1986). The aedeagus of the male was cut off at the base and the female genital capsule with aedeagus intact was extracted from the posterior end of the abdomen, excised, and placed into a petri dish containing water. The ventral side of the genital capsule was cut through and removed which allowed a view of the undisturbed insertion of the internal sac into the bursa copulatrix. Photomicrographs were taken with a Wild Heerbrugg M5 stereoscopic microscope with phototube and 35 mm camera operated with a Wild Heerbrugg Photoautomat.

Spermatophore and Sperm Cell of *Cicindela splendida*

Fresh spermatophores of *C. splendida*, ejected from the gonopore of female *C. limbalis*, were prepared for histological examination by light microscopy, scanning electron microscopy (SEM) and transmission electron microscopy (TEM) using techniques modified from those described by Pease (1964), Lillie (1965), Dawes (1971), Ladd (1973), Flechon et al. (1975), Humason (1979), and O'Brien and McCully (1981).

For SEM, several fresh spermatophores were placed in a droplet of distilled water on a depression slide. Some of the spermatophores were crushed to liberate the sperm,

using forceps and teasing needles. The droplet containing whole spermatophores, crushed spermatophores and free sperm in suspension was pipetted onto NUCLEPORE membrane filters (pore diameter 0.2 μm , filter diameter 25 mm) within the MILLIPORE filtering apparatus which uses vacuum to draw solutions over the filter paper. The specimens were rinsed once with distilled water and fixed with 5% Alcohol-Formol-Acetic fixative (AFA--90 ml of 70% ethanol, 5 ml of 100% formalin, 5 ml of glacial acetic acid) for 6 hours and rinsed again with distilled water in the filtering apparatus. Filter papers with attached specimens were placed into distilled water and cut to SEM stub size using a cork borer (diameter 14 mm). The filters were then placed into a small perforated plastic BEEM capsule and dehydrated in a graded series of acetone (30%, 50%, 70%, 90%, 100%, 100%) in distilled water for 30 minutes in each solution. The capsules with the samples, while still wet with 100% acetone were placed in a SORVALL Critical Point Dryer and dried with liquid carbon dioxide (CO_2) at approximately 20°C. The pre-cooled pressure chamber was rinsed with CO_2 for 2 minutes and then closed for 5 minutes to allow for substitution of liquid carbon dioxide for acetone. This procedure was repeated for 5 rinse cycles. After the last soak, the critical point for CO_2 (31.1°C and 1070 psi) was obtained by warming of the pressure chamber. After pressure rise and equalization, the pressure in the chamber was reduced to

atmospheric over a period of approximately 5 minutes. The filter papers were then removed from the capsules, mounted on SEM stubs using double back Scotch tape, sputter coated with gold in a Fullam EMS-76M sputter coater and photographed at 7.5 or 15 KV on a Cambridge Stereoscan 600 SEM.

For TEM, fresh spermatophores were placed in a small glass vial 3 cm in diameter and 3 cm in height and fixed in sodium phosphate buffered gluteraldehyde (6.0% gluteraldehyde in 0.05 M sodium phosphate buffer with pH 7.3 at 20°C) for 3 hours. The solutions were changed by using a pipette taking care not to allow the specimens to dry out while changing the solutions.

The specimens were then rinsed 3 times for 1 hour periods with 0.05 M sodium phosphate buffer with pH 7.3 at 20°C. In the safety of a fume hood the specimens were placed in 1% osmium tetroxide (1% O_8O_4 in 0.05 M sodium phosphate buffer with pH 7.3 at 20°C) for 1 hour and then rinsed 2 times with distilled water. They were then dehydrated in a graded series of acetone (50%, 70%, 95%, 100%, 100%) in distilled water for 30 minutes in each solution. The specimens were then placed into a graded series of Spurr epoxy resin (Spurr, 1969) in acetone (1:2, 1:1, 2:1) for 30 minutes in each solution. Due to the thick viscosity of the Spurr solution, the vial containing the specimens was placed on an inclined rotating turntable to insure mixing of the solution, thus aiding in the infiltration of Spurr into the

tissue. The specimens were then placed into 100% Spurr twice at 1 hour each and the vial rotated to insure mixing. The specimens were then removed from the vial using a blunt flat hooked applicator stick or splinter of wood and placed into BEEM capsules which were then filled with 100% Spurr reagent. The BEEM capsules were then cured in an oven at 70°C for approximately 12 to 16 hours.

The embedded spermatophores were sectioned on a SORVALL PORTER-BLUM MT2-B Ultramicrotome, equipped with glass knives. The sections, 70 to 100 nm thick, were floated on distilled water and transferred to 75 x 300 nickel mesh TEM grids (3 mm diameter). The sample was dried and stained with either lead citrate for 10 minutes or a combination of uranyl acetate followed by lead citrate, this latter method yielding better staining results, for 10 minutes in each solution as explained by Dawes (1971). The samples were viewed and photographed with a Philips PW 6001 TEM.

Ten embedded spermatophores were also sectioned for light microscopy. Serial sections, 0.5 to 1 um thick, were made of the spermatophore at intervals of 10 um to reveal its structure. The sections were floated on distilled water, transferred to glass slides, covered by a chloroform vapour filled vial to relax and flatten the sections, stained for 1 to 5 minutes in 1% toluidine blue in 1% aqueous sodium borate and mounted in Permount histological mountant.

The slides were photographed using a Zeiss Standard

18 Research Compound Microscope equipped with Zeiss Planachromat objectives, Zeiss Type C-35 mm Photomicrographic camera and Ikophot-M exposure meter. Photomicrographs of the sperm cell were taken at high power with an oil emersion objective and with Nomarski differential interference-contrast equipment for transmitted light. Kodak Technical Pan Film 2415 was developed to high contrast using Kodak HC-110 developer, dilution D for 6 minutes. All films were printed on Ilfospeed multigrade II polycontrast resin coated paper using an Omega Type B8 Enlarger and processed via the tray processing method.

Tiger beetle sperm cells, obtained from crushed spermatophores, were prepared for TEM using negative staining. For this several fresh spermatophores were placed into a droplet of distilled water on a depression slide and crushed to liberate the sperm, using forceps and teasing needles. The droplet containing free sperm in suspension was pipetted onto the carbon coated Formvar substrate on a 200 mesh TEM grid. The sample was then dried slightly and stained with bovine serum base, phosphotungstic acid stain in potassium hydroxide with pH 7.2. After 30 seconds the excess fluid was drained from the grid by touching its edge to filter paper. The grid was allowed to dry and was viewed and photographed with a Philips PW 6001 TEM.

RESULTS AND DISCUSSION

Copulating Phases and Mating Behaviour in *Cicindela limbalis* and *Cicindela splendida*

Observations of 15 conspecific mating pairs in each of *C. splendida* and *C. limbalis* as well as 15 interspecific matings between males of *C. splendida* with females of *C. limbalis* revealed similar behaviour. Males of *C. limbalis* did not attempt mating with females of *C. splendida*. This suggests males of *C. limbalis* do not respond sexually to *C. splendida* females. Specific recognition by males of *C. limbalis* appears to be an effective isolating mechanism not demonstrated by the males of *C. splendida*.

Females of *C. limbalis* and *C. splendida* ejected spermatophores from males of either species. It was not possible to determine if the females discriminated between males of different species because the previous mating history of the female was unknown. To test the discriminating ability of the female, virgin females would have to be mated with males of different species to observe the acceptance or rejection of a spermatophore.

The observation that females can accept or reject the spermatophore which has been transferred gives support to the female choice hypothesis as outlined by Eberhard (1985). According to this hypothesis, females discriminate among males of their own species on the basis of the males' genitalia, and that males with favoured genitalic structural

features sire more offspring than others. This hypothesis is based on the suppositions that: (1) genitalia of some males within a species may more effectively enter the female or hold the male in place such that he introduces more sperm into an advantageous position inside the female where the sperm are more likely to fertilize the eggs; (2) stimuli from the genitalia of some males may be more effective in eliciting essential female reproductive processes, so that copulation is not terminated prematurely, sperm is transported to storage and/or fertilization sites, ovulation occurs, the eggs mature, stored sperm is nourished, the fetus is implanted, or further attempts at copulation are resisted. Eberhard's hypothesis helps to explain how and why female tiger beetles discriminate among males. Furthermore, I suggest that females might discriminate among males' genitalia, not only of their own species but also that of other species based on their ability to fit mechanically, or perhaps more importantly, through other sensations or stimuli occurring in her genital region. Probably this failure of species recognition has led to regions of hybridization in the natural environment.

Beetles which mated exhibited phase 1 and 2 of copulation as described by Freitag et al. (1980) but did not clearly exhibit phase 3. During the latter part of phase 2, the male repeatedly flexed or pumped his aedeagus for several seconds at a time. This movement probably represented phase

3 which as proposed by Schincariol and Freitag (1986) is the phase in which the internal sac is everted into the bursa copulatrix.

During the latter part of phase 2 and early phase 3 of some copulated pairs the internal sac was everted into the bursa copulatrix and the spermatophore was positioned between membranous tissue at the base of the everted internal sac and the dorsal posterior membrane of the bursa copulatrix (Fig. 1). Because freezing was performed during an initial mating attempt after only several minutes of copulation, the presence of a spermatophore suggests that males carry a pre-made spermatophore in reserve which can be transferred quickly to the female in an initial mating attempt. The presence of two spermatophores within united genitalia was also observed; perhaps one being from a previous mating and the second one newly transferred.

Phase 2 lasted 3 to 5 minutes during initial mating, whereas in the second mating it took approximately 15 minutes and increased by one minute with each subsequent copulation. Intercopulatory rest periods ranged from 10 to 15 minutes after initial mating and increased by 1 to 2 minutes each time thereafter. These findings were consistent among conspecific and interspecific mating pairs. Repeated copulation and contact guarding by males during time spans ranging from 6 to 10 hours occurred among all mating pairs.

These behavioural observations imply that the

spermatophore is produced by the male during intercopulatory rest periods and that as suggested by Kraus and Lederhouse (1983), riding behaviour appears to be a "post-copulatory guarding phase" which may increase the likelihood of paternity for the riding male, by protecting his spermatophore against replacement by other males. The increased length of time during and between copulation attempts and the apparent reduced size of subsequent spermatophores indicate that the males require progressively longer resting periods between copulations to produce spermatophores and that material for the spermatophore may also be limiting as noted by Sakaluk (1985) for the cricket *Gryllodes*. Sakaluk (1985) stated that the costs males incur in the production and packaging of ejaculates may be manifest in these ways: (1) longer intercopulatory intervals; (2) increased copulation times; and (3) decreased ejaculate volumes accompanying subsequent matings. Chapman (1982) stated that in the mosquito *Aedes*, when copulations follow each other in rapid succession only some of them result in successful insemination because the supply of sperm is limited. Males of the wax moth *Galleria*, which copulated within three hours of a previous copulation produced only small spermatophores some of which were devoid of sperm (Chapman, 1982).

Female tiger beetles usually ejected the spermatophore within 5 seconds of withdrawal of the aedeagus

by the male. In this process the female protruded her ovipositor slightly so as to touch the substrate. While pressing her ovipositor toward the substrate she simultaneously manipulated her valves and moved forward slightly, squeezing the spermatophore out of her genitalia and rubbing and sticking it to the surface of the substrate. Females made no attempt to find or eat the spermatophore.

Spermatophore and Sperm Cell of *Cicindela splendida*

The spermatophore of *C. splendida* consisted of a two-chambered capsule (Fig. 2), the outer surface of both being rippled and cratered (Fig. 3). The large capsule measured approximately 0.5 X 0.3 mm and consisted of two layers of porous or spongy-like tissue which enclosed an irregularly shaped lumen (Fig. 4). A portion of the large capsule wall extended into the second chamber, measuring 0.25 X 0.15 mm, and referred to here as the lateral capsule. The extension of the large capsule wall in conjunction with the porous spongy-like wall of the lateral capsule, formed a narrow connecting channel between the chambers. The porous spongy layer of the lateral capsule occurred only on the side adjacent to the large capsule. The remainder of the lateral capsule was bound by a membrane. The lateral capsule consisted of an irregularly shaped inner layer of homogeneous material which surrounded a mass of sperm cells and other cellular material (Fig. 5). Although the same homogeneous

material in the lateral capsule may also be mixed with the inner porous spongy layer of the large capsule, no sperm cells were evident. The lumen of the large capsule held a few scattered cells which appeared to be suspended, and was thus probably fluid filled.

The sperm appear randomly oriented within the homogeneous material of the lateral chamber (Figs. 6 and 7). Other cellular material (Figs. 8 to 11), consisting of mitochondria and rough endoplasmic reticulum may represent remains of tissues sloughed off from the testes or other parts of the male genital tract. Bacteria (Figs. 12 and 13), were found occasionally within the lateral chamber, most likely the result of their presence in the male genital tract.

Sperm cells negatively stained for TEM (Figs. 14 to 17), as well as those critically point dried for SEM, had a head approximately 2.0 to 2.5 times greater than the tail diameter. The head was little differentiated from the tail. This is consistent for most insects (Davey, 1965). A detailed account of the structure of the head and tail junction of *Cicindela* sperm is given by Werner (1965).

There appeared to be two generalized forms of sperm in *C. splendida*. The more prevalent form had an enlarged head diameter tapering to a moderately long thinner tail diameter (Figs. 14, 15, 18 and 19). The less prevalent form had the appearance of a very long thin sperm cell with the

head diameter only slightly larger than the tail diameter (Figs. 16, 20, 21 and 22). Many intermediate forms between these two types also occurred (Fig. 17). It is probably not possible by means of negative staining to state with certainty the existence of only two distinct types. Baccetti and Afzelius (1976) stated that in some animal species there are two or more distinct sperm types mixed within the ejaculate and that in the most pronounced instances, one type of spermatozoa has a normal nucleus and is able to achieve fertilization, whereas the other type of sperm has a small nucleus (or none) and apparently cannot penetrate the egg. These authors also note that among insects, there are taxa in which more than two sperm cells coexist within the semen, and give as examples, the wasp *Dahlbominus*, which has at least five different sperm types and the fruit fly *Drosophila*, where two or more sperm types occur within the same male. Individual sperm differ in size and structure within a species and within an ejaculate (Beatty, 1975 and Cohen, 1975). Abnormal shapes are probably the result of faults in spermatogenesis (Baccetti and Afzelius, 1976). External factors such as high temperature can result in abnormal sperm in Saxon Merino ram ejaculate (Williamson, 1974) and diseases such as the common cold or factors such as stress will cause an increase in the number of abnormal sperm cells in humans (Baccetti and Afzelius, 1976). The structural variation within samples of *Cicindela* sperm cells may have been caused

by some external factors and are not necessarily indicative of distinct types.

Examination with TEM of sections of sperm cells embedded within the lateral capsule of the spermatophore revealed internal structure similar to that described by Smith (1968) for most insects and by Werner (1965) for *C. campestris*. A longitudinal section through a sperm tail shows the axoneme and the two adjacent mitochondrial nebenkerns (Fig. 23) and probably a sperm head and the core of the tail (Fig. 24). A cross-section of a sperm tail shows the axoneme of 9+9+2 microtubules (Figs. 25 and 26), the accessory body alongside the axoneme, the two mitochondrial nebenkerns and the core (Figs. 27 and 28). Further cross-sections illustrate aberrant sperm cells which contained two tails bound by a membrane (Figs. 29 and 30).

Mechanism of Spermatophore Formation and Transfer

The evidence from this study suggests modification to the mechanism of spermatophore formation for *Cicindela* as proposed by Freitag (1966). The spermatophore is probably produced within the posterior portion of the inverted internal sac of the aedeagus rather than the anterior portion of the bursa copulatrix as proposed by Freitag (1966). The brevity during which a spermatophore can be transferred in an initial mating suggests that the male carries a pre-made spermatophore within the internal sac. The porous textured

surface of the spermatophore, the complexity of the walls and layers, and the presence of two lobes suggest that the spermatophore is formed in an area or field of spines and solidifies around a structure such as one of the sclerites of the internal sac, producing a bilobed structure, with one lobe containing fluid and one lobe containing sperm cells. Possibly the posterior portion of the inverted internal sac is the location of spermatophore formation. The anterior portion is filled with sclerites which evert first into the bursa copulatrix, gripping and expanding it so that the spermatophore contained posteriorly, can be deposited into the dorsal posterior membranes of the bursa copulatrix as was seen in frozen pairs.

The position of the spermatophore in the posterior portion of the bursa differs from that noted by Freitag (1966) who found sperm and remains of the spermatophore positioned within the confines of the dorsal portion of the ventral lobes, the ventral sclerite of the bursa copulatrix and the surrounding anterior inner surface of the bursa, all of which are covered by spines or setae. Perhaps the deposition of the spermatophore, and the flexing movements of the aedeagus during the latter part of phase 2, serve to move the spermatophore anteriorly between or over the ventral lobes, or to stimulate the female bursa to contract to cause this forward movement of the spermatophore.

Freitag (1966) and Schincariol and Freitag (1986)

proposed that after copulating tiger beetles separate, the spermatophore is torn open on the setae of the ventral sclerite by contractions of the muscles that surround the bursa. The free sperm then swim or are forced through the spermathecal duct to the spermatheca, but it is not known which of the two methods are employed, or if both are employed.

Morphological evidence provided by Werner (1965) and in this study revealed that *Cicindela* sperm has the common 9+9+2 pattern of microtubules making up its axoneme. Phillips (1970) and Baccetti (1972) stated that with few exceptions, most insect orders possess this pattern of accessory tubules, doublets and central tubules. Baccetti (1972) and Baccetti and Afzelius (1976) in describing patterns of sperm movement, state that 9+9+2 insect sperm move with three-dimensional, helicoidal waves. Possibly *Cicindela* sperm are liberated from their capsule within the bursa copulatrix and then swim toward the spermatheca. Rhythmic contractions of the bursa copulatrix and the spermathecal duct, which would help to propel the sperm cells along, cannot be ruled out, as this was not tested in this study.

- Fig. 1. Photomicrograph of united male and female genitalia illustrating the internal sac (InS) everted into the bursa copulatrix (BCx) and a spermatophore (Sph) between them.
- Fig. 2. Scanning electron micrograph of the large capsule (LgC) and the lateral capsule (LtC) of the spermatophore.
- Fig. 3. Scanning electron micrograph of the rippled and cratered surface of the spermatophore.
- Fig. 4. Photomicrograph of a section through the spermatophore illustrating the layers of material which form the large capsule (LgC) with its irregularly shaped lumen (Lu) and the lateral capsule (LtC), as well as the sperm mass (SM) within the lateral capsule.
- Fig. 5. Photomicrograph of sperm mass (SM) within the lateral capsule taken with Nomarski phase contrast.
- Fig. 6-7. Transmission electron micrographs illustrating the random orientation and density of sperm within the lateral capsule of the spermatophore.
- Fig. 8. Transmission electron micrograph of a section through the lateral capsule of the spermatophore showing various cellular components.

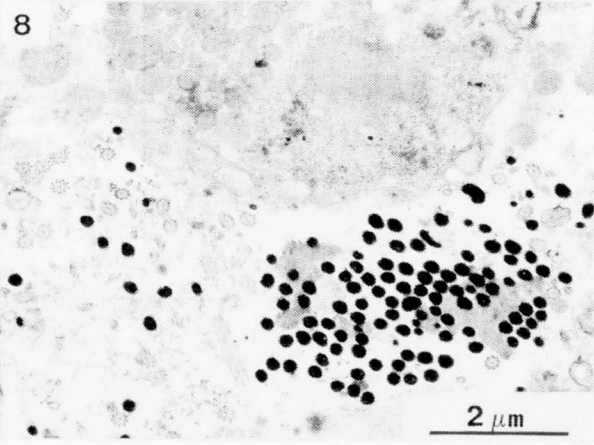
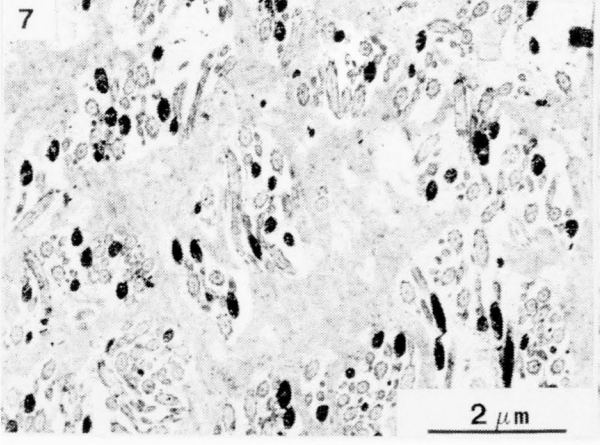
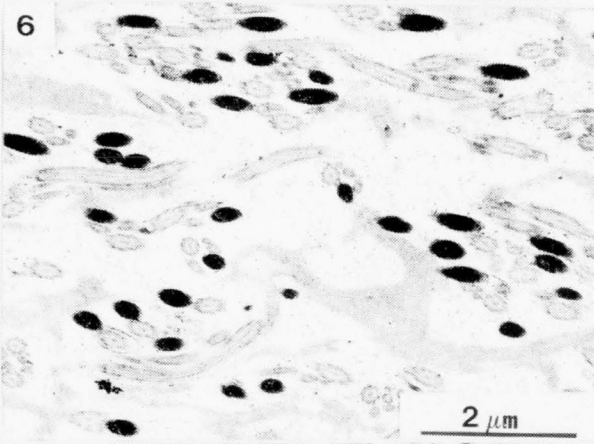
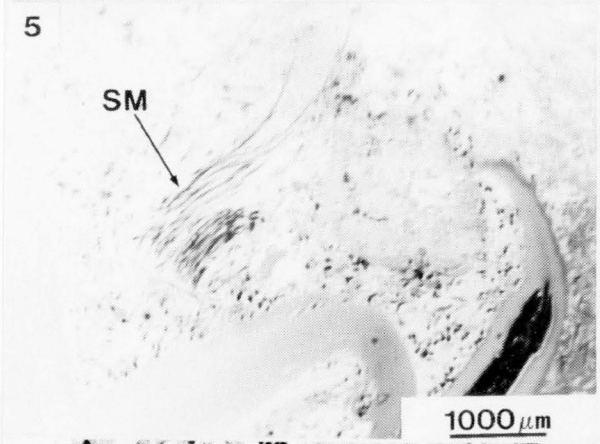
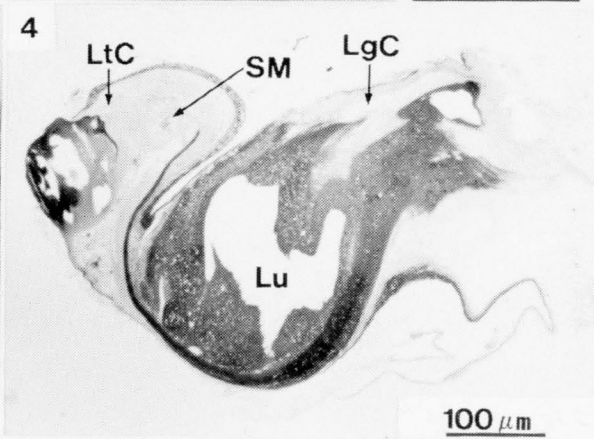
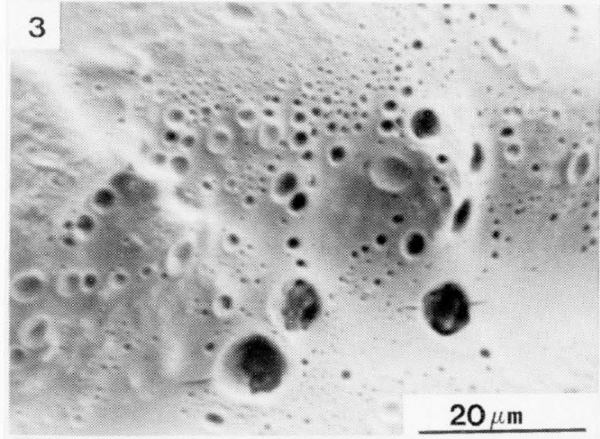
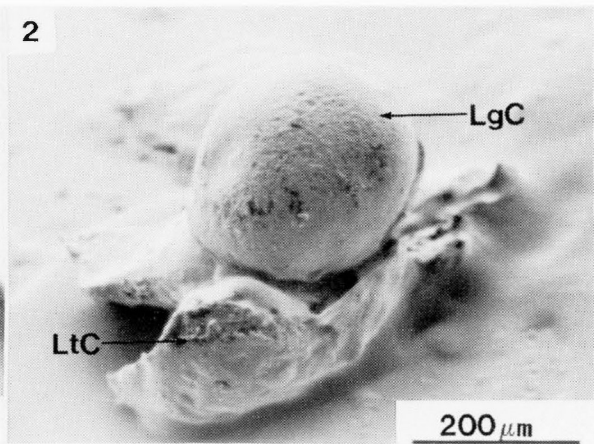
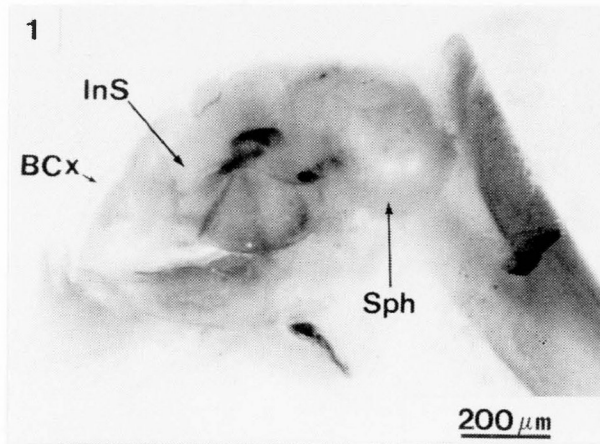

- Fig. 9-11. Transmission electron micrographs of a layer of tissue found embedded within the spermatophore, illustrating many large mitochondria (M), the "cytoplasm" which contains ribosome-studded cisterne of the endoplasmic reticulum (RER) and embedded sperm tails (ST).
- Fig. 12-13. Transmission electron micrograph of bacteria embedded in the lateral capsule.
- Fig. 14-16. Transmission electron micrographs of sperm cells as seen by means of negative staining.

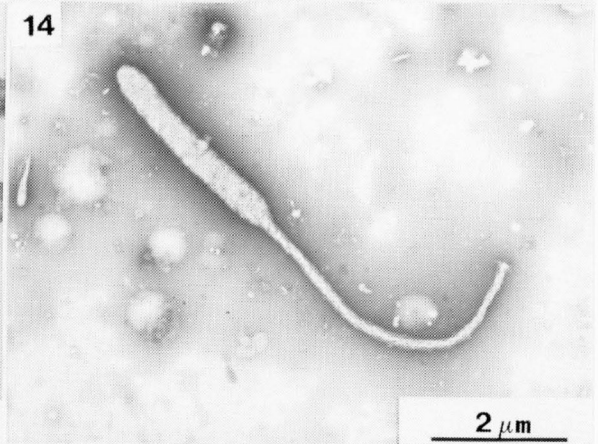
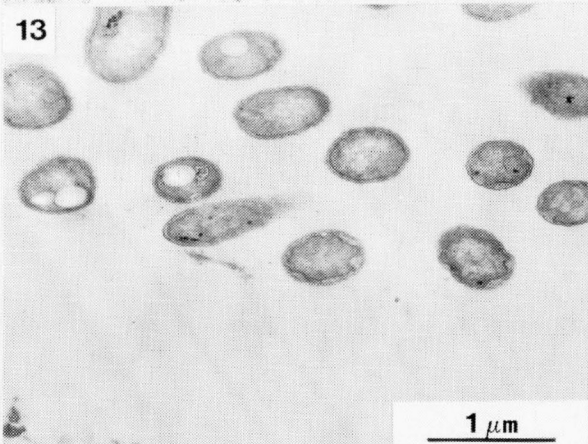
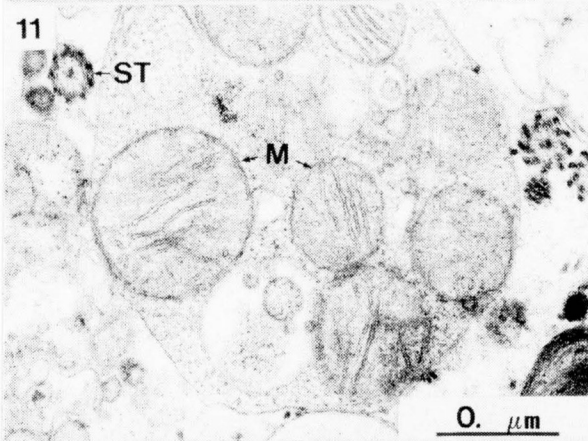
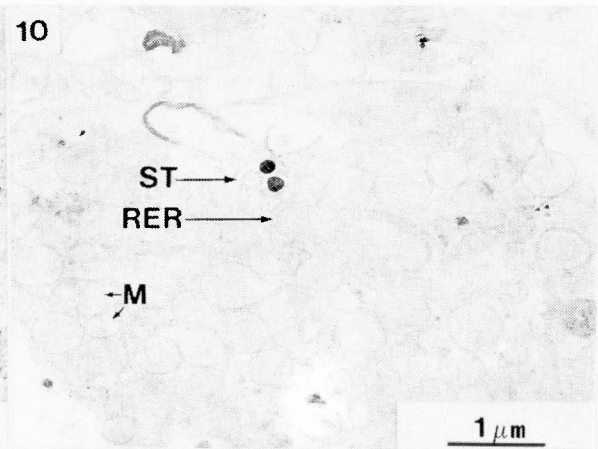
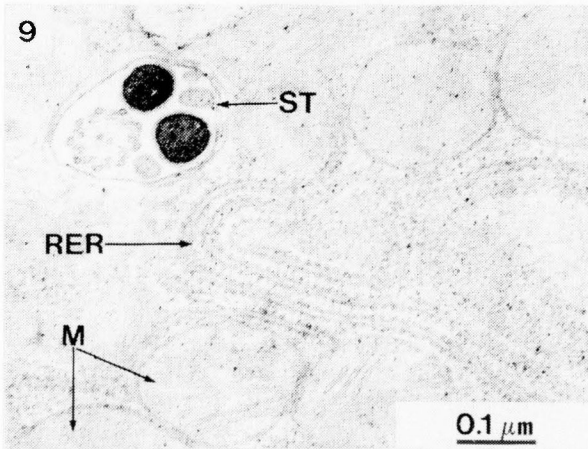

- Fig. 17. Transmission electron micrograph of a sperm cell as seen by means of negative staining.
- Fig. 18-19. Scanning electron micrographs of the more prevalent sperm form which has an enlarged head diameter tapering to a moderately long thinner tail diameter.
- Fig. 20-22. Scanning electron micrographs of the less prevalent sperm form which appears to be very long with the head diameter only slightly larger than the tail diameter.
- Fig. 23. Transmission electron micrograph of a longitudinal section through a sperm tail, illustrating the axoneme (Ax) and the two adjacent mitochondrial nebenkerns (MN).
- Fig. 24. Transmission electron micrograph of a section through a sperm head and core of the tail.

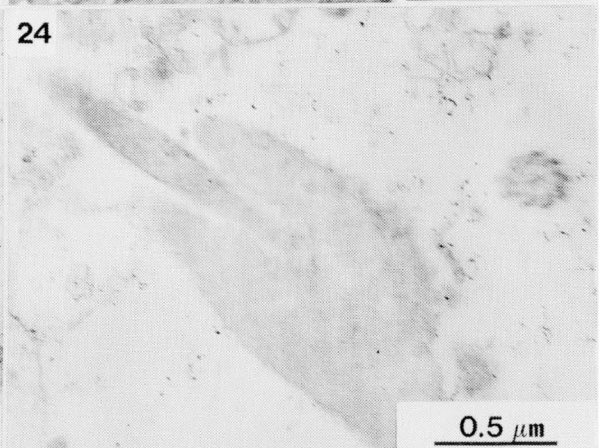
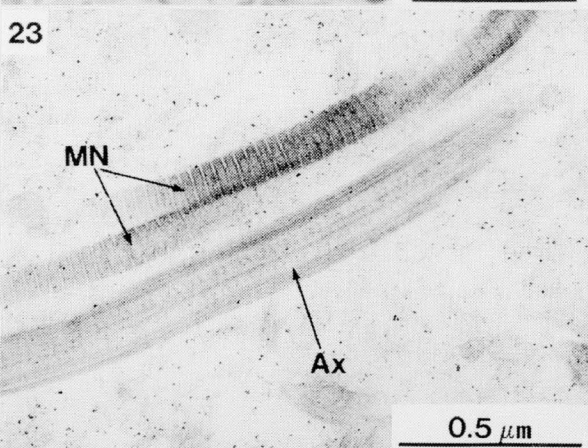
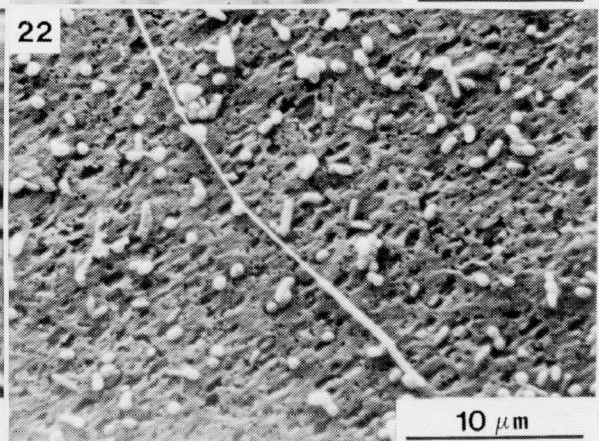
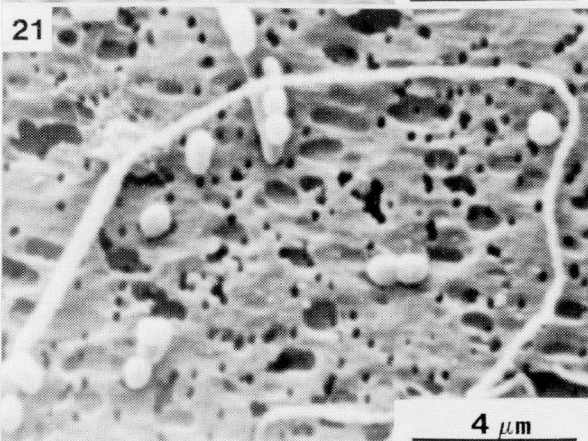
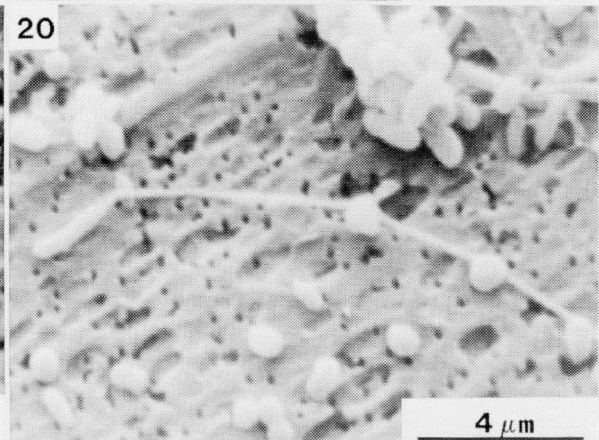
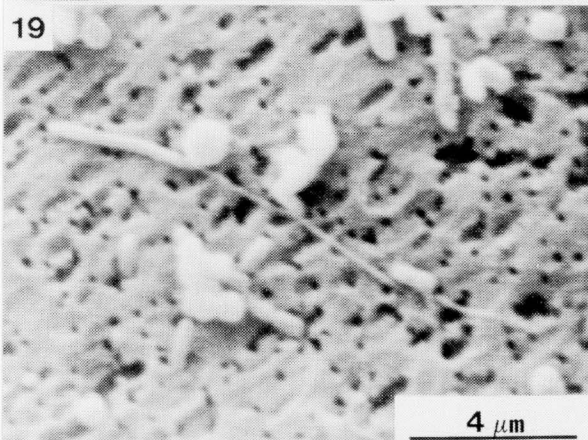
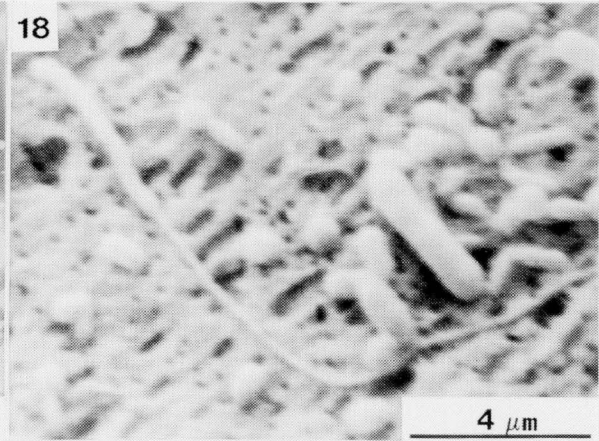
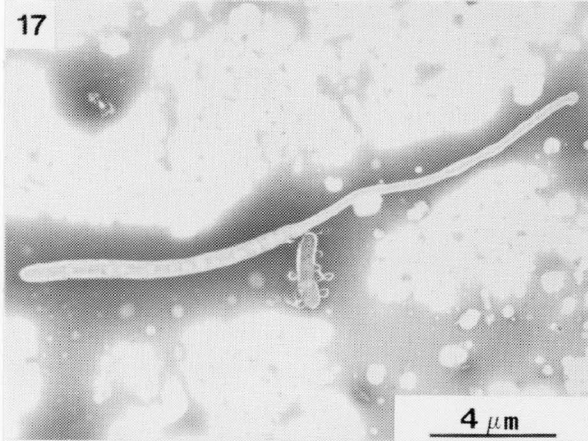

- Fig. 25-26. Transmission electron micrographs of a cross section of a sperm tail illustrating the axoneme with its 9+9+2 pattern of accessory tubules (AT), doublets (D) and central tubules (CT).
- Fig. 27. Transmission electron micrograph of a cross section of a sperm tail illustrating the axoneme (Ax) of 9+9+2 microtubules, the accessory body (AB) alongside the axoneme, the two mitochondrial nebenkerns (MN) and the core (C).
- Fig. 28. Transmission electron micrograph of a cross section of several sperm tails which are cut at different regions along their length.
- Fig. 29-30. Transmission electron micrograph of a cross section of a possible aberrant sperm cell with two tails bound by a membrane.

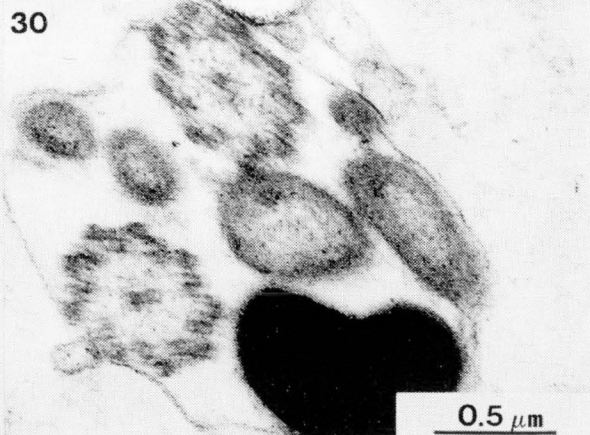
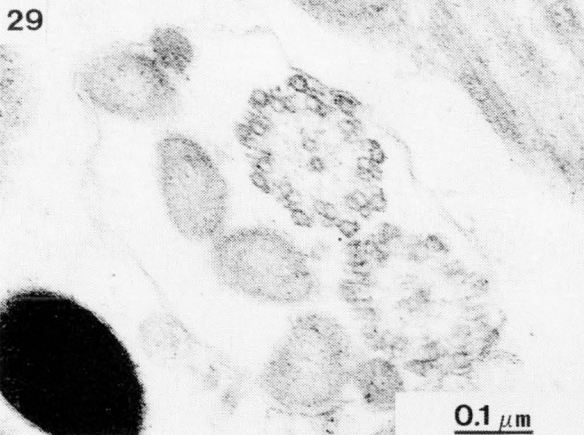
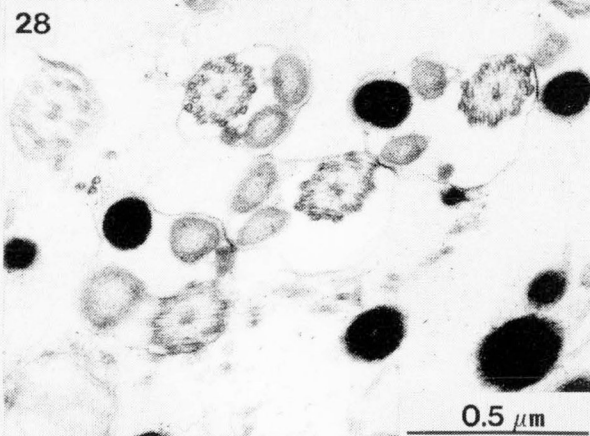
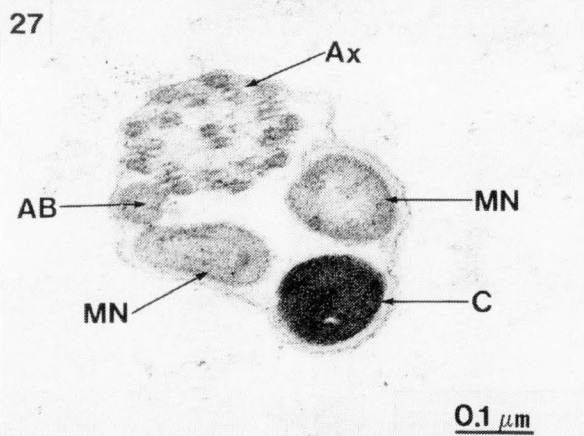
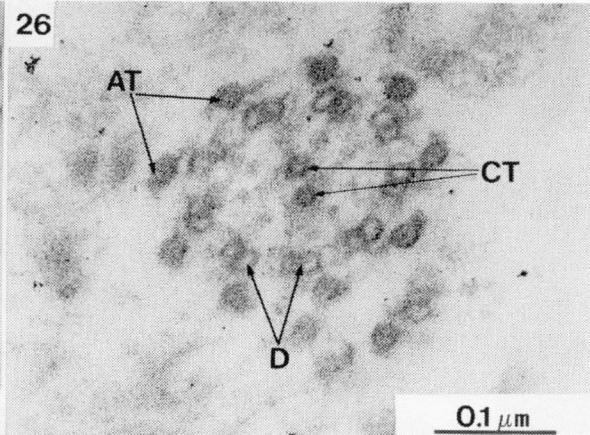
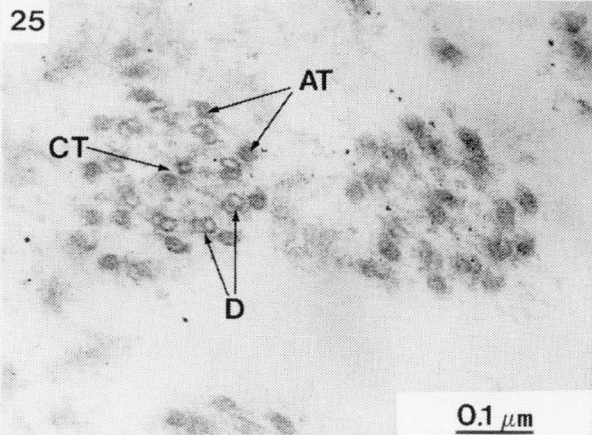

Part B

Ecology
and
Systematics

INTRODUCTION

Species of North American tiger beetles of the genus *Cicindela* are for the most part well known taxonomically. Adult specimens can be identified as a result of publications by Schaupp (1883), Wickham (1894), Leng (1902a), Horn (1908, 1938), Harris and Leng (1916), Cazier (1936, 1948), Wallis (1961), and Willis (1968) to mention only a few. Hamilton (1925) described many larvae.

Shelford (1907, 1908, 1913b, 1917), and Criddle (1907, 1910) have studied life cycles and ecology of North American species. Willis (1967) described the bionomics and zoogeography of tiger beetles of saline habitats in the central United States. Mury-Meyer (1983) studied the survivorship and foraging methods of three species of sympatric tiger beetle larvae. Knisley and Pearson (1984) described the biosystematics of larval tiger beetles of the Sulphur Springs Valley of Arizona.

With some exceptions, the descriptive and classificatory taxonomy of the North American species is in a reasonable state. Attention must now be directed to taxonomic studies at the species level. Only within the past two decades have studies focused on population and zoogeographic problems within species and species groups.

Many of the species of North American tiger beetles have extensive geographic ranges with adults exhibiting pronounced variation in size, colour, elytral maculation, and

pilosity (Horn, 1908; Shelford, 1917; Smyth, 1933, 1935; Wallis, 1961; Willis, 1967). Analysis of this variation has resulted in recognition of many subspecies, varieties and other variants, followed by much synonymy and confusion over the status of formally named taxa. Several taxonomic works dealing with intraspecific variation in the Cicindelidae include Freitag (1965), Willis (1967), Gaumer (1977), Leffler (1979), Kaulbars (1982), Spanton (1983, 1988), Graves et al. (1987) and Graves (1987). However, serious systematic problems remain, especially within the *Purpurea* complex (Willis, 1968; Rumpff, 1980, 1984). I investigated the taxonomic status of the *Purpurea* subcomplex known as the *C. splendida* group which consists of the species *C. splendida*, *C. limbalis* and *C. denverensis* Casey.

The study was designed to determine the distinctness of *C. splendida*, *C. limbalis* and *C. denverensis* by investigating possible isolating mechanisms as well as interspecific variation within the group. Thus, premating isolating mechanisms such as seasonal and habitat isolation, ethological isolation and mechanical isolation were investigated. Numerical analyses of morphometric data was also conducted.

The objectives were as follows: (1) to determine if *C. splendida*, *C. limbalis* and *C. denverensis* are distinct species or subspecies of one highly variable species; (2) to attempt interbreeding of the "species" under laboratory

conditions, to verify field observations of interspecific copulation, and to describe larvae resulting from such a mating; (3) to determine the phenology and ecology of *C. limbalis* and describe or redescribe, if necessary as many of its immature life stages as possible (i.e., egg; 1st, 2nd and 3rd instars; pupa); (4) to provide comparisons of male and female genitalia within the group; (5) to compare soil associations for the species within the group; (6) to investigate the pattern of intraspecific and interspecific variation in this group by means of numerical analyses of morphometric data; (7) to apply correctly available names to recognized taxa; (8) to discuss the factors which may influence elytral colour and maculations for the species within the group; (9) to hypothesize relationships among the taxa; and (10) to determine the biogeography for the whole group.

Taxonomic History

The species *C. limbalis* is highly variable in colour and maculation (Leng, 1902a; Shelford, 1917). Six synonyms and one subspecies are recognized by Boyd and Associates (1982).

Klug (1834) described *C. limbalis*, designating the type locality as North America. Other species closely related to *C. limbalis* are dealt with in this study. The species *C. splendida* was described by Hentz (1830), who

designated North Carolina as type locality. Casey (1897) described *C. denverensis* and designated Denver, Colorado as type locality. *Cicindela ludoviciana* Leng was described as a new variety of *C. purpurea* Olivier, with type locality Vowell's Mill, Nachitoches Parish, northwestern Louisiana (Leng, 1902a).

Schaupp (1883) treated both *C. splendida* and *C. limbalis* as varieties of *C. purpurea*. Casey (1897) described *C. denverensis* as a new species related to *C. purpurea*. Wickham (1899) stated that *C. denverensis* was only a variety of *C. purpurea*. Many subsequent authors continued to use Schaupp's classification of this group. Leng (1902a) separated *C. splendida* from *C. purpurea* on colour alone, and assigned *C. limbalis*, *C. denverensis*, and two new forms, *C. transversa* and *C. ludoviciana* to the status of varieties of *C. purpurea*. Casey (1913) stated that *C. limbalis* was a species different from *C. purpurea* and that *C. splendida* was also a "limbalis-like species". Casey (1913) also described two subspecies of *C. limbalis*, i.e. *awemeana* and *eldorensis*, presently considered conspecific with of *C. limbalis*. Horn (1908), grouped several names including *C. splendida*, *C. limbalis*, *C. denverensis*, *C. transversa* and *C. ludoviciana* under *C. purpurea*.

Nicolay and Weiss (1932) recognized *C. purpurea*, *C. limbalis* and *C. splendida* as separate species but placed *C. transversa* as a variety of *C. limbalis* and *C. denverensis* and

C. ludoviciana as varieties of *C. splendida*. Their work was severely criticized by Smyth (1933), who argued that there was little reason to consider *C. splendida* as a species distinct from *C. limbalis*. He also questioned the reasoning by Nicolay and Weiss (1932) that distinct species could mingle with their intermediate forms in the same locality and retain their specific identity, and he criticized groupings based wholly upon colour and maculation. Smyth's addition of the new specific names, *sedalia* and *plattensis* was without foundation since he did not give formal descriptions or assign type specimens and thus added to the already overburdened synonymy within the *Purpurea* group. The arguments continued in publications by Nicolay (1934) and Smyth (1935). Eckhoff (1939) recognized *C. purpurea*, *C. splendida*, and *C. limbalis* as separate species. He placed *C. transversa* as a variety of *C. limbalis* and described a new variety of *C. splendida* which he named *cyanoccephalata*.

Willis (1968) recognized the difficulty of separating the species of the *Purpurea* group. He separated *C. splendida* from *C. limbalis* on the basis of colour alone, as others had done before him.

Lawton (1972) indicated that in several states *C. splendida* and *C. limbalis* were found in equal numbers on steep clay banks. He also stated that in one of these collecting sites, a population contained every conceivable development of maculae, suggesting three phenotypes of *C.*

limbalis. Where *C. splendida* and *C. denverensis* were together, Lawton (1972) noted that the former preferred the base of the clay banks in or near advancing grasses, whereas the latter preferred the higher extremities, even the vertical cliffs where it often rested in the deep crevices.

Graves and Pearson (1973) stated that Pearson observed a "ludoviciana" male in coitus with a typical red *C. splendida* female. Their comparison of the genitalia of two male "ludoviciana" with those of typical red *C. splendida* revealed no differences. Thus, they concluded that "ludoviciana" was a green colour phase of *C. splendida* which was more common in certain populations. Shelford (1917) stated that in western Kansas and Colorado, the red form *C. splendida* and a green form occurred together and were often taken in coitus. He considered the green form to be a colour aberration of the red form.

Rumpp (1980) used genitalic structures of male tiger beetles to split Rivalier's Group VII (type: *C. formosa* Say) and to reconstruct a phylogeny for the resultant Formosa and Purpurea groups. His preliminary morphological examination of the genitalia of *C. splendida*, *C. limbalis* and *C. denverensis* revealed minor differences in male genitalia and he concluded that *C. splendida* and *C. limbalis* were conspecific but that *C. denverensis* was a separate species.

Rumpp (1981) stated that the structure is the same for both *C. splendida* and *C. limbalis* and that colour and

extent of maculation were the only obvious differences allowing one to distinguish two "species". However, he further stated that even the maculation was so variable that this could be discounted, leaving only colour to make differentiation possible. Rumpp (1983, 1984) stated that, after reevaluation of previous work on *C. denverensis*, data were insufficient to support the slight differences in the tooth inside the internal sac of the aedeagus as being sufficiently important to warrant species status.

Johnson (1983) stated that *C. splendida*, *C. limbalis*, *C. denverensis* and *C. ludoviciana* are one species due to the presence of intergrade populations.

The occurrence in the natural environment of interspecific copulation among these species was reported by Lantz (1905) for *C. denverensis* and *C. splendida*, by Smyth (1907) for *C. splendida* and *C. transversa*, by Nicolay (1934) for *C. limbalis* and *C. transversa*, by Eckhoff (1939) for *C. limbalis* and *C. splendida cyanocephalata*, by Graves and Pearson (1973) for *C. ludoviciana* and *C. splendida*, by Johnson (1983) for *C. denverensis* and *C. limbalis*, and by David W. Brzoska (pers. comm.) for *C. limbalis* and *C. splendida*.

MATERIALS AND METHODS

Adult Specimens and Loaning Institutions

More than 9,500 adult specimens were examined of which 640 specimens were used in the numerical analyses. Most of these specimens were obtained on loan from the following institutions and private collections. Wherever possible standard codens have been used for collections of insects as proposed by Heppner and Lamas (1982). Individuals at each institution dealt with are listed in recognition of their assistance. The number of specimens from each collection is also given using the following code:
 l = *limbalis*, s = *splendida*, and d = *denverensis*.

AMNH American Museum of Natural History, Department of Entomology, Central Park West at 79th Street, New York, New York, 10024

Lee H. Herman (121 l, 130 s, 58 d)

BGSU Bowling Green State University, Department of Biological Sciences, Bowling Green, Ohio, 43403

Robert C. Graves (122 l, 10 s)

BM Bryant Mather, 213 Mt. Salus Rd., Clinton, Mississippi, 39056

(5 l, 1 s)

CAES The Connecticut Agricultural Experimental Station, Department of Entomology, 123 Huntington Street, P.O. Box 1106, New Haven, Connecticut 06504-1106

Kenneth A. Welch (1 l)

CAS California Academy of Sciences, Department of Entomology, Natural History Museum & Aquarium, Golden Gate Park, San Francisco, California, 94118-9961

David H. Kavanaugh and Roberta L. Brett (446 l, 219 s, 37 d)

CC Claude Chantal, 883 Des Erables, C.P. 2072, St. Nicolas-Est, Quebec, G0S 3L0

(11 l)

CDAS California State Collection of Arthropods, Insect Taxonomy Laboratory, State of California, Department of Food and Agriculture, 1220 N Street, Sacramento,

California, 95814

Fred G. Andrews (21 1)

CMP Carnegie Museum of Natural History, Section of
Entomology, Carnegie Institute, 4400 Forbes Avenue,
Pittsburgh, Pennsylvania, 15213

Robert L. Davidson (87 1, 1 s)

CNC Canadian National Collection of Insects, Biosystematics
Research Institute, K.W. Neatby Bldg., C.E.F. Ottawa,
Ontario, K1A 0C6

John E. H. Martin and Jean McNamara (255 1, 29 s, 12 d)

CSU Colorado State University, Department of Entomology,
Fort Collins, Colorado, 80523

Boris C. Kondratieff and Howard E. Evans (18 1, 4 s,
8d)

CU Cornell University Insect Collections, Department of
Entomology, Cornell University, Comstock Hall, Ithaca,
New York, 14853

James K. Liebherr (44 1)

CUSC College of Agricultural Sciences, Department of
Entomology, 114 Long Hall, Clemson University, Clemson,
South Carolina, 29631-2688

Kevin M. Hoffman (2 1, 41 s)

DWB David W. Brzoska, 826 Iowa Street, Lawrence, Kansas,
66044

(18 1)

EJK Eric J. Kiteley, 16-13th Street, Roxboro, Quebec, H8Y
1L4

(5 1)

FEM Frost Entomological Museum, Department of Entomology,
Pennsylvania State University, University Park,
Pennsylvania, 16802

(17 1)

FMNH Field Museum of Natural History, Roosevelt Road at Lake
Shore Drive, Chicago, Illinois, 60605-2496

- John B. Kethley and Cynthia Milkint (25 l, 45 s, 3 d)
- IL Irwin Leeuw, 1219 Crystal Lake Road, Cary, Illinois,
60013

(329 l)
- INHS Illinois State Natural History Survey, 172 Natural
Resources Building, 607 East Peabody Drive, Champaign,
Illinois, 61820

Donald W. Webb and Kathryn C. McGiffen (134 l, 92 s)
- ISU Iowa State University Insect Collection, Department of
Entomology, Iowa State University, Ames, Iowa, 50011

Robert E. Lewis (62 l, 2 s)
- JDG John D. Glaser, 6660 Lock Hill Road, Baltimore,
Maryland, 21239

(49 l)
- KSU Kansas State University, Department of Entomology,
Waters Hall, Manhattan, Kansas, 66506

H. Derrick Blocker (8 l, 216 s, 16 d)
- LACM Natural History Museum of Los Angeles County, 900
Exposition Boulevard, Los Angeles, California, 90007

Charles L. Hogue (91 l, 82 s, 36 d)
- LEM Lyman Entomological Museum and Research Laboratory,
Macdonald College, McGill University, 21111 Lakeshore
Road, Ste. Anne de Bellevue, Quebec, Canada, H9X 1C0

Vernon R. Vickery (29 l)
- LSU Louisiana State University, Department of Entomology,
402 Life Sciences Building, Baton Rouge, Louisiana,
70803-1710

Cheryl B. Barr (8 l)
- LU Lakehead University, Department of Biology, Thunder
Bay, Ontario, P7B 5E1

Richard Freitag (829 l, 28 s, 3 d)
- MCZ Museum of Comparative Zoology, The Agassiz Museum,
Department of Entomology, Harvard University,

Cambridge, Massachusetts, 02138

A. F. Newton and Paul J. Johnson (380 l, 245 s, 102 d)

MPM Milwaukee Public Museum, Section of Invertebrate
Zoology, 800 West Wells Street, Milwaukee, Wisconsin,
53233

Gerald R. Noonan (204 l)

MSUB Montana State University, Department of Biology,
College of Letters and Science, Bozeman, Montana, 59717

Sharon Rose (10 l, 8 s)

NCSR North Carolina State University Insect Collection,
Department of Entomology, North Carolina State
University, Box 7613, Raleigh, North Carolina,
27695-7613

Carol Parron (6 l, 206 s, 1 d)

NDSU North Dakota State University of Agriculture and
Applied Science, Department of Entomology, 202 Hultz
Hall-Box 5346, State University Station, Fargo, North
Dakota, 58105

Edward U. Balsbaugh, Jr. (1,406 l, 57 s, 256 d)

OKS K. C. Emerson Museum, Department of Entomology,
Oklahoma State University, Stillwater, Oklahoma, 74078

William A. Drew (5 l)

PMA Alberta, Culture, Provincial Museum of Alberta,
12845-102nd Avenue, Edmonton, Alberta, T5N 0M6

Albert Finnamore and Tim Spanton (75 l)

PSU Pennsylvania State University, Department of Biology,
208 Erwin W. Mueller Laboratory, University Park,
Pennsylvania, 16802

David L. Pearson (40 l, 8 s, 11 d)

REA Robert E. Acciavatti, 2111 Cherry Street, Marion
Meadows, Morgantown, West Virginia, 26505

(94 l)

ROM Royal Ontario Museum, Department of Entomology, 100
Queen's Park, Toronto, Ontario, M5S 2C6

- Glenn B. Wiggins (82 l)
- SMEK Snow Entomological Museum, Department of Entomology,
University of Kansas, Lawrence, Kansas, 66045-2106
- George W. Byers (35 l, 41 s, 5 d)
- SMNH Saskatchewan Museum of Natural History, Department of
Culture and Recreation, Wascana Park, Regina,
Saskatchewan, S4P 3V7
- Ronald R. Hooper (9 l)
- SUNY State University of New York, College of Environmental
Science and Forestry, Syracuse Campus, Syracuse, New
York 13210
- Frank E. Kurczewski and Michael A. Valenti (5 l)
- UAE University of Alberta, Strickland Museum, Department of
Entomology, Edmonton, Alberta, T6G 2E3
- George E. Ball and Danny Shpeley (83 l, 14 s, 1 d)
- UAF University of Arkansas, Division of Agriculture,
Department of Entomology, 320 Agriculture Building,
Fayetteville, Arkansas, 72701
- Chris Carlton (2 l, 27 s)
- UCB University of California, at Berkeley, Division of
Entomology, College of Natural Resources, Berkeley,
California, 94720
- Gary W. Ulrich (53 l)
- UCD University of California, at Davis, Department of
Entomology, Davis, California, 95616
- Robert O. Schuster (1 l)
- UGA University of Georgia, Department of Entomology Museum,
Athens, Georgia, 30602
- Cecil L. Smith (13 l)
- UGO University of Guelph, Ontario Agricultural College,
Department of Environmental Biology, Guelph, Ontario,
N1G 2W1
- Steve Marshall (17 l)

- UIM University of Idaho, Department of Entomology, College of Agriculture, Moscow, Idaho, 83843
Frank Merickel (6 l)
- UMAA University of Michigan, Museum of Zoology, Ann Arbor, Michigan, 48109
Mark F. O'Brien (185 l, 104 s, 39 d)
- UMSP University of Minnesota, Department of Entomology, 219 Hodson Hall, 1980 Folwell Avenue, St. Paul, Minnesota, 55108
Philip J. Clausen (227 l, 38 s, 1 d)
- UMW University of Manitoba, Department of Entomology, Room 214 Animal Science Bldg., Winnipeg, Manitoba, R3T 2N2
Terry D. Galloway (14 l)
- UNL University of Nebraska State Museum Research and Systematics Collections, Division of Entomology, University of Nebraska, W-436 Nebraska Hall, Lincoln, Nebraska, 68588-0514
Brett C. Ratcliffe (73 l, 28 s, 17 d)
- USNM National Museum of Natural History, Smithsonian Institution, NHB 169 Entomology, Washington, D.C., 20560
Terry L. Erwin, Gloria N. House and Gary F. Hevel (575 l, 331 s, 53 d)
- UVB University of Vermont, Department of Zoology, Marsh Life Science Building, Burlington, Vermont, 05405-0086
Ross T. Bell (346 l, 10 s)
- UWM University of Wisconsin-Madison, College of Agricultural & Life Sciences, Department of Entomology, 237 Russell Laboratories, 1630 Linden Drive, Madison, Wisconsin, 53706
Steven Krauth (15 l, 7 s)
- UWW University of Waterloo, Faculty of Science, Department of Biology, Waterloo, Ontario, N2L 3G1
Anne Morgan (2 l)

VPI Virginia Polytechnic Institute and State University,
Department of Entomology, Blacksburg, Virginia, 24061

Michael Kosztarab (2 l, 4 s)

WJ Walter Johnson, 2917 16th Avenue South, Minneapolis,
Minnesota, 55407

(60 l, 14 s, 41 d)

WSU James Entomological Collection, Department of
Entomology, Washington State University, Pullman,
Washington, 99164-6432

Richard S. Zack (1 l, 14 s)

Characters and Measurements

The following adult characters employed in this study are similar to those used by Gaumer (1977), Kaulbars (1982) and Spanton (1983, 1988). These characters were found to be constant. The number and pattern of setae on the antennal scape was used to distinguish among species of *Cicindela* (Willis, 1968). Colour and elytral maculations figured prominently in the descriptions of species and subspecies within the *C. splendida* group which resulted in names applied to individual variants, and to variant populations. I attempted to elucidate the pattern of variation in characters of colour and elytral maculations. The alphanumeric characters in brackets following each character in the subsequent list are abbreviations used in this text.

1. Total head width across the widest point on the eyes (hw) (Fig. 31)
2. Labral length including the median tooth (ll) (Fig. 31)
3. Labral width (lw) (Fig. 31)
4. Ratio: labral length/labral width (ll/lw)

The setal pattern on the labrum was used as another character. The number of setae in each of four locations on the frontal surface of the labrum was indicated (Fig. 32)

5. Number of setae in position 1 (ls1)
6. Number of setae in position 2 (ls2)

7. Number of setae in position 3 (ls3)
8. Number of setae in position 4 (ls4)

The number of sensory setae (ss) and the number of other setae (os) on the first segment (scape) of the antennae was indicated. (Fig. 33)

9. Number of sensory setae on the scape of the left antenna (ssl)
10. Number of sensory setae on the scape of the right antenna (ssr)
11. Number of other setae on the scape of the left antenna (osl)
12. Number of other setae on the scape of the right antenna (osr)
13. Pronotal length (pl) (Fig. 34)
14. Pronotal width (pw) (Fig. 34)
15. Ratio: pronotal length/pronotal width (pl/pw)
16. Ratio: pronotal width/head width (pw/hw)
17. Mesothoracic femur length (fl) (Fig. 35)
The left mesothoracic leg was chosen preferentially. Where the left was missing, the same measurement from the right leg was used. The mesothoracic leg was chosen because prothoracic and metathoracic legs were more frequently missing from pinned specimens.
18. Mesothoracic tibia length (tl) (Fig. 35)
The selection was the same as the aforementioned character.
19. Ratio: mesofemur length/mesotibia length (fl/tl)
20. Width of left elytron at its widest point (ew) (Fig. 36)
21. Length of left elytron (el) (Fig. 36)
This was measured from the apex of the scutellum along the medial edge of the elytron to its apex.
22. Ratio: elytral width/elytral length (ew/el)
23. Percent of elytral surface covered by maculations. A series of specimens representing the range of variation within the group was selected. A drawing of the left elytron of each specimen was prepared. A computer graphics

tablet was used to determine the percentage of each elytron covered by maculations. Subsequently, these drawings were used as standards of comparison for estimating the percentage to the nearest one of six categories: 3%, 6%, 13%, 23%, 26% and 34% (Fig. 37)

24. The configuration of the humeral lunule (hl)
Six states of this character were recognized. (Fig. 38)

- 1) humeral lunule absent
- 2) one humeral dot present at shoulder of the elytron
- 3) one subhumeral dot present
- 4) both humeral dots present
- 5) humeral lunule complete or nearly so
- 6) humeral lunule complete and connected to marginal line

25. The configuration of the middle band (mb)
Specimens were categorized as being closest to one of the following states of this character (Fig. 39)

- 1) middle band consisting of transverse bar only
- 2) middle band very thin and frequently broken into two pieces
- 3) middle band complete with transverse bar and descending bar of uniform thickness
- 4) middle band complete with transverse bar thicker than descending bar
- 5) middle band complete and connected to marginal line

26. Apical lunule character states (al)
The following states represent the degree of development of the apical lunule (Fig. 40)

- 1) apical lunule consisting of apical dot only
- 2) apical lunule broken into two pieces
- 3) apical lunule complete or nearly so
- 4) apical lunule continuous with marginal line

27. Colour of dorsal surface of elytra (ec) (Table 1)
Table 1 contains the designated colour character code and corresponding colour name and number from the ISCC-NBS colour charts by Kelly and Judd (1965). To establish this table a small series of specimens chosen to represent the range of colour variation in the group was compared to the ISCC-NBS colour charts and the corresponding colour name and number were noted. Subsequently, specimens used in the analysis were compared against standard specimens and designated as being closest to one of the representative colour categories.

Population Samples

Character states and measurements were taken from adult specimens from 24 different localities across the range of the species group; 6 population samples of *C. splendida*; 15 population samples of *C. limbalis* and 3 population samples of *C. denverensis* (Table 2, Fig. 41). Although an effort was made to choose larger samples of populations from localities throughout the ranges of the three species, it was necessary to use a few samples with less specimens. These small samples, however, were analyzed with the knowledge that they may have been atypical because of biased sampling by collectors favouring unusual forms over the typical ones.

Fig. 31-33. Characters of the adult head of *C. limbalis*.

Fig. 31. Head, frontal aspect: hw, head width; ll, labrum length; lw, labrum width.

Fig. 32. Labrum, frontal aspect: number of setae at position one (ls1), position two (ls2), position three (ls3) and position four (ls4).

Fig. 33. Left antenna, frontal aspect: number of sensory setae (ss) and other setae (os) on the first segment (scape) of antenna.

31

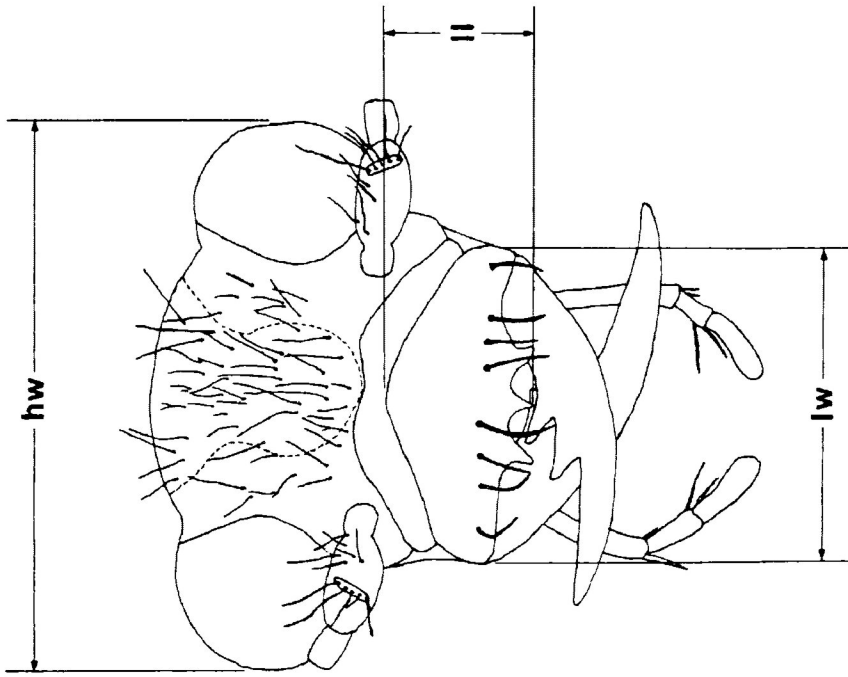

1mm

32

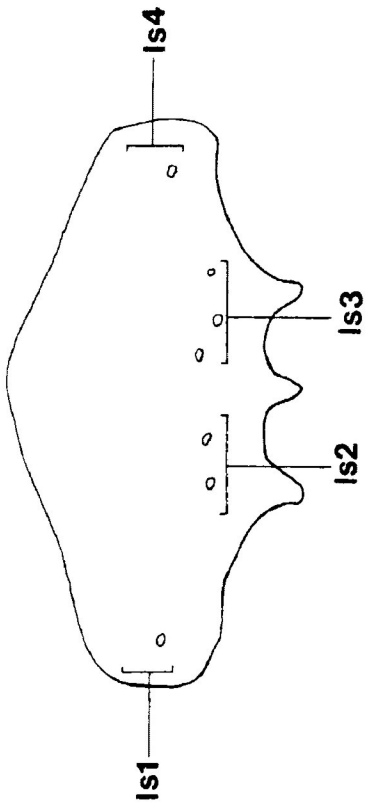

1mm

33

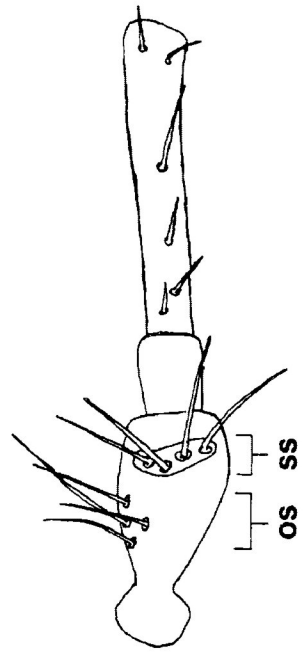

1mm

Fig. 34. Adult pronotum of *C. limbalis*, dorsal aspect:
pw, pronotal width; pl, pronotal length.

Fig. 35. Left mesothoracic leg of *C. limbalis*, frontal
aspect: fl, femur length; tl, tibia length.

34

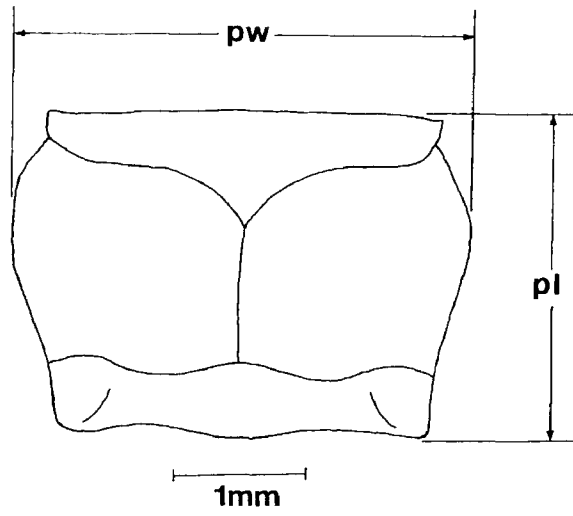

35

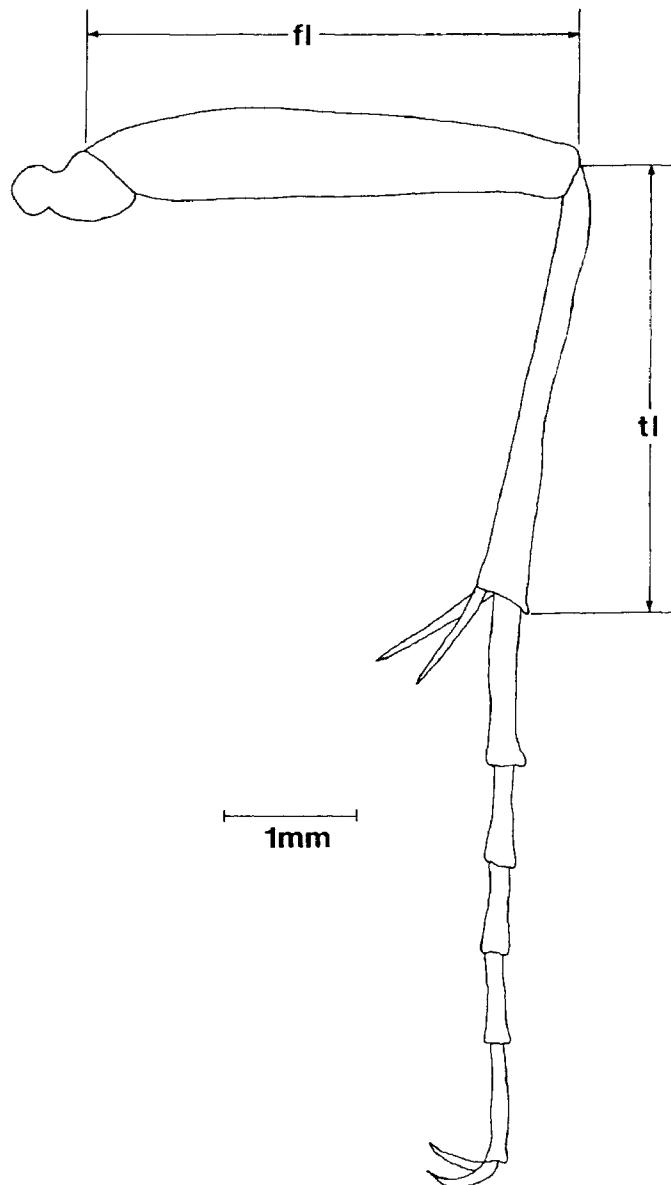
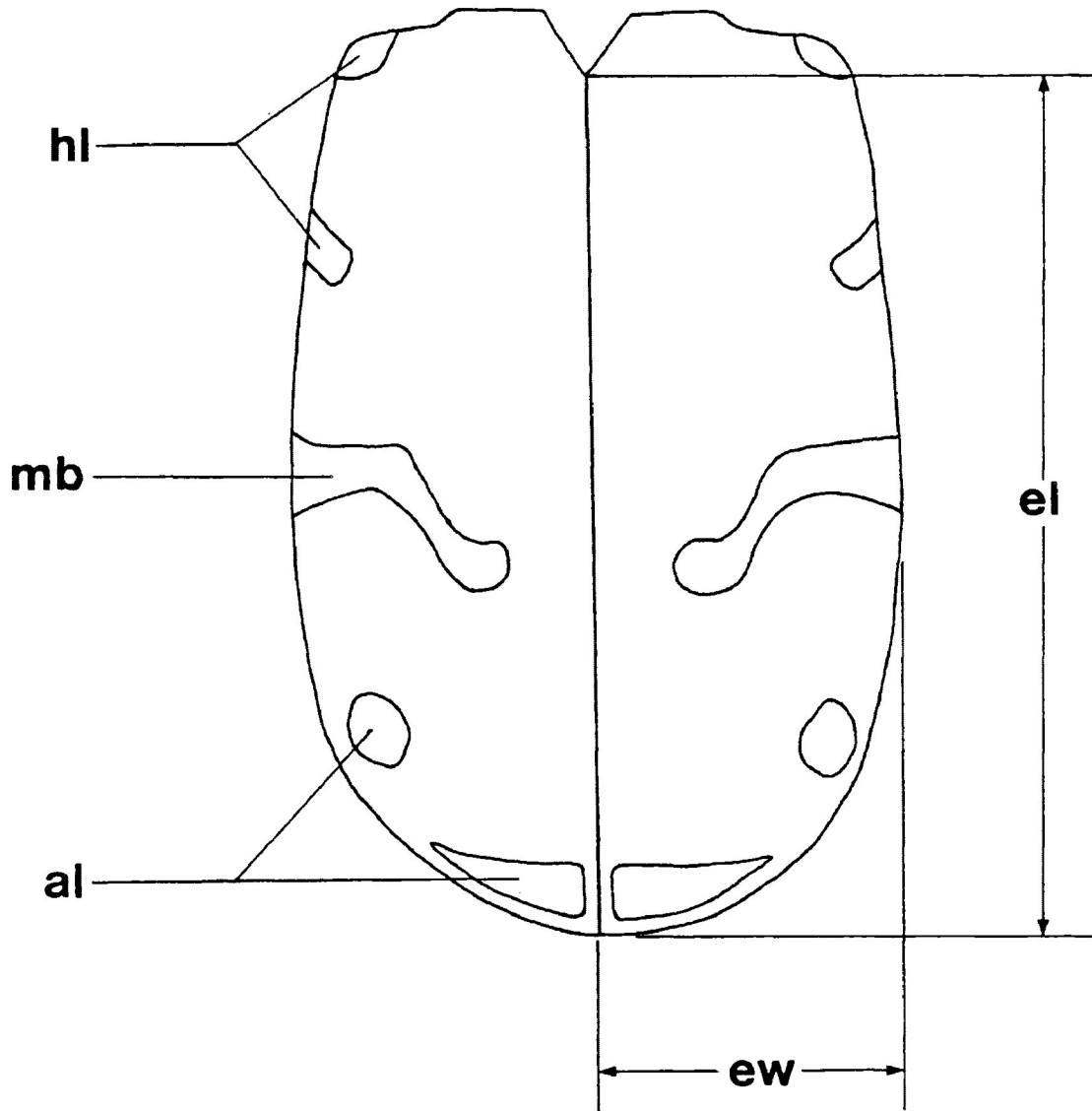

Fig. 36. Adult elytra of *C. limbalis*, dorsal aspect: el, elytral length; ew, elytral width; hl, humeral lunule; mb, middle band; al, apical lunule.



1mm

Fig. 37. Percent of elytral surface covered by light maculations.

- A. 3%
- B. 6%
- C. 13%
- D. 23%
- E. 26%
- F. 34%

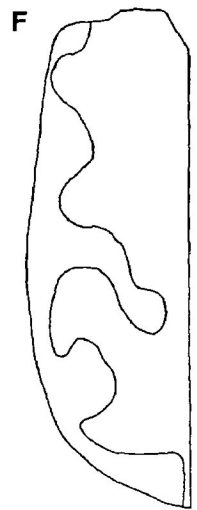
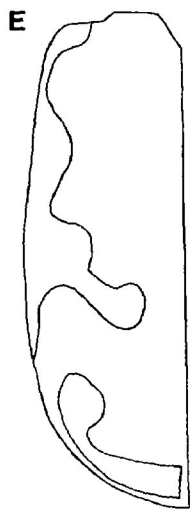
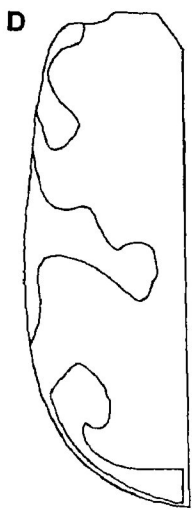
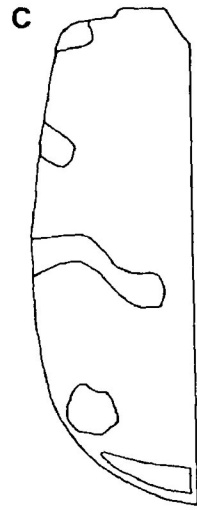
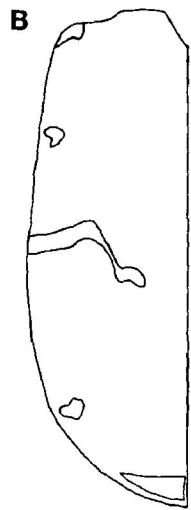
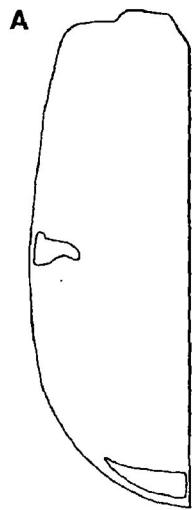

1mm

Fig. 38. Humeral lunule character states. The number at the lower left corner of each drawing indicates the arbitrarily assigned value described in the materials and methods.

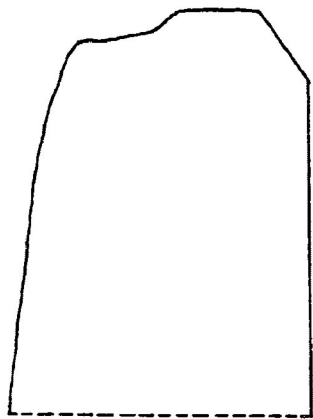

1

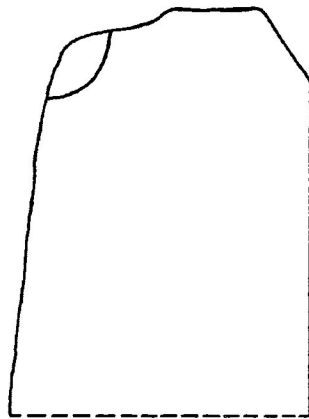

2

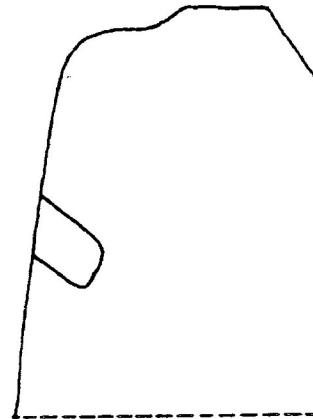

3

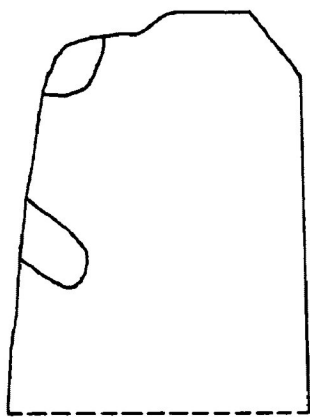

4

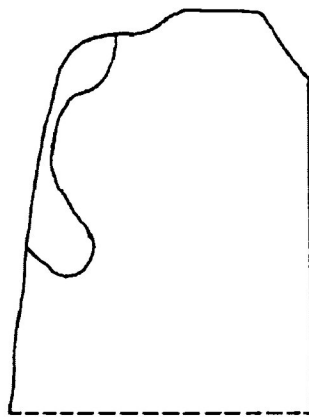

5

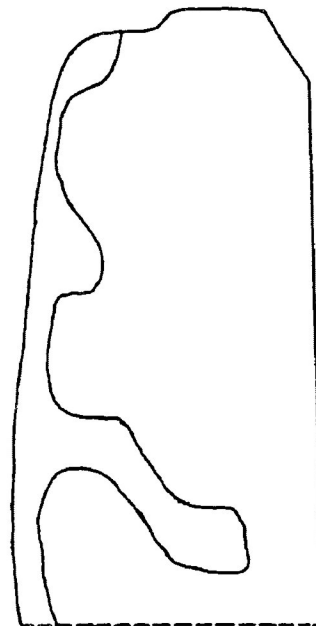

6

1mm

Fig. 39. Middle band character states. The number at the lower left corner of each drawing indicates the arbitrarily assigned value described in the materials and methods.

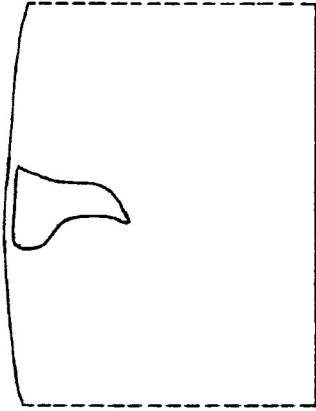

1

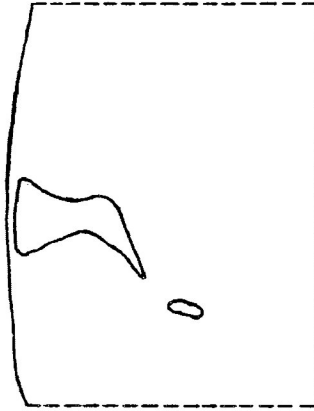

2

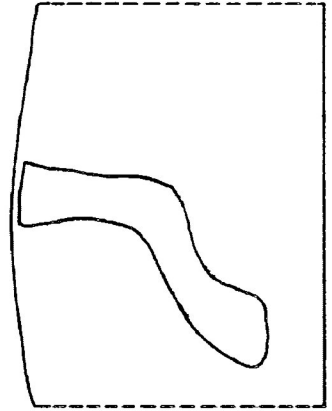

3

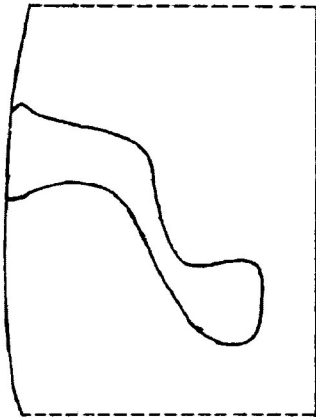

4

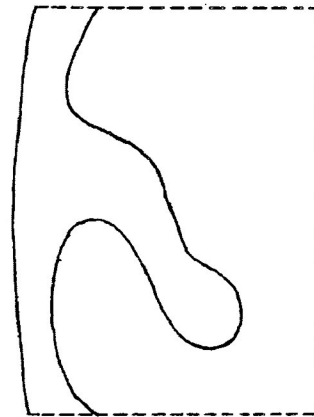

5

1mm

Fig. 40. Apical lunule character states. The number at the lower left corner of each drawing indicates the arbitrarily assigned value described in the materials and methods.

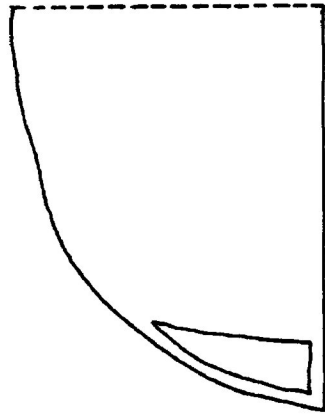

1

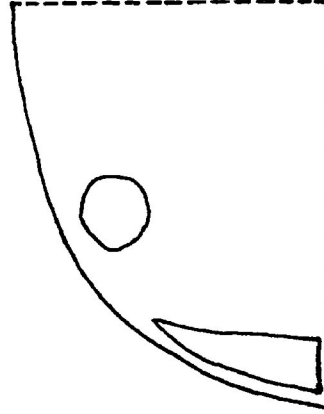

2

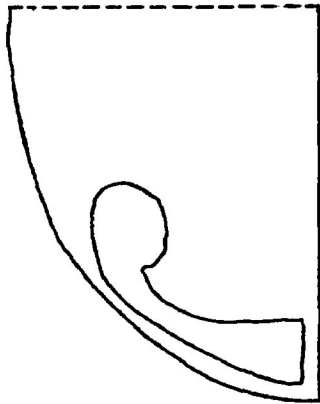

3

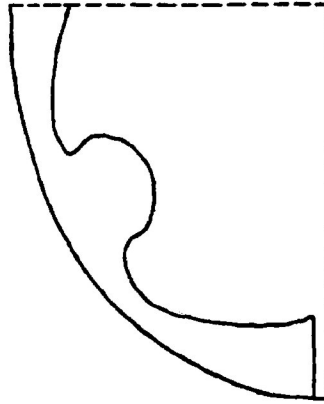

4

1mm

Table 1. Designated states for colour of dorsal surface of elytra of *C. splendida*, *C. limbalis*, and *C. denverensis*.

ISCC-NBS Number	ISCC-NBS Name	Character Code Number
44	Dark Reddish Brown	1
47	Dark Grayish Reddish Brown	2
62	Dark Grayish Brown	3
75	Deep Yellowish Brown	4
118	Deep Yellow Green	5
142	Deep Green	6
147	Very Dark Green	7
174	Dark Greenish Blue	8
183	Dark Blue	9
243	Very Dark Reddish Purple	10

Table 2. Population samples (n) of *C. splendida* (6), *C. limbalis* (15), and *C. denverensis* (3) used in numerical and colour analyses.

SPECIES	CODE	LOCALITY	MALES	FEMALES
<i>C. splendida</i>	AR1	Arkansas: Hope	15	15
	KS1	Kansas: McPherson	7	11
	NC1	North Carolina: Asheville	13	15
	NE1	Nebraska: Lincoln	15	10
	SC1	South Carolina: Walhalla	15	10
	VA1	Virginia: Mount Vernon	15	15
			Species Total	80
<i>C. limbalis</i>	AB1	Alberta: Edmonton	15	15
	CO2	Colorado: Douglas County, Sedalia	15	15
	IA1	Iowa: Sioux City	15	15
	IL1	Illinois: Glencoe	15	15
	MB1	Manitoba: Aweme (now Treesbank)	15	15
	ME1	Maine: Mt. Desert Isl.	15	15
	MO1	Missouri: Louisiana	15	14
	NE2	Nebraska: Omaha	15	15
	NJ1	New Jersey: Greenwood Lake	15	15
	NS1	Nova Scotia: North Sydney	7	4
	NT1	Northwest Territories: Norman Wells	9	15
	ON1	Ontario: Thunder Bay, Kaministiquia River	15	15
	PQ1	Quebec: Montreal	15	14
	SD1	South Dakota: Rapid City	11	6
	SK1	Saskatchewan: Saskatoon	12	5
		Species Total	204	193
<i>C. denverensis</i>	CO3	Colorado: Denver	15	15
	ND1	North Dakota: Dunn County	15	15
	NE3	Nebraska: Benkelman	15	12
		Species Total	45	42
		Grand Total	329	311

Fig. 41. Population samples (n) used in numerical and colour analyses of *C. splendida* (6), *C. limbalis* (15) and *C. denverensis* (3).

Numerical Analyses of Morphometric Data

The analyses of character states were performed on the Lakehead University VAX-11/780 computer (DEC VAX-11/780 VMS V4.2) using statistical programs from SPSS-X (release 2.2 for VAX/VMS) as outlined in the SPSS-X User's Guide, 2nd ed. (1986). The statistical procedures and programs of SPSS-X are described by Norusis (1983, 1985). In the numerical analyses of morphometric data, unless otherwise stated, the accepted level of significance was 0.05.

Sexual dimorphism was examined in each of the species groups by comparing males against females for each of the variables with the use of a one-way analysis of variance (ONEWAY) procedure (parametric test) and with a Kruskal-Wallis One-Way Analysis of Variance (nonparametric test). Both tests were applied as cross references for each other. Because females in each species were significantly larger in overall size than males, data for each sex were treated separately in subsequent analyses.

Intraspecific variation was examined in each of the three species groups by comparing, for each sex, each of the variables by population location with the use of a one-way analysis of variance (ONEWAY) procedure. From the resulting matrix tables it was possible to determine whether populations within a species were significantly different from one another and which variables differed. By examining and comparing the mean value of each variable for each

population location it was possible to examine trends and clinal variation among populations.

The data for each of the variables in each sex for each species group was tested for normality using a Kolmogorov-Smirnov One-Sample Test (Goodness of Fit Test). Within each species group and sex category continuous variables (body measurements and ratios) followed a normal distribution or had acceptable levels of skewness and kurtosis, while discontinuous variables (body colour, elytral patterns and setae number) were not normally distributed in most samples. Although several data transformations were attempted none were successful in normalizing the data and thus were not used. Since discriminant analysis requires that all variables within a data set be normally distributed a factor analysis which does not require normally distributed data was performed to create a set of orthogonal (uncorrelated) factors which are made up of correlated variables from the original data set. These factors were then employed in the discriminant analysis. A Pearson Correlation (PEARSON CORR) test (parametric test) and a nonparametric (NONPAR CORR) test using Kendall and Spearman coefficients were performed for all variables within each sex category. Both the parametric and nonparametric test results, which were very similar, revealed many correlated variables which could be linked to form factors in the factor analysis, thus giving further support for this method of

testing. Also, performing factor analysis prior to discriminant analysis improved the interpretation of the discriminant results since the original variable list was reduced to a few factors containing correlated variables.

The factor analysis was performed using all variables and consisted of a principal components analysis and varimax rotation of the factor matrix. Varimax rotation attempts to minimize the number of variables that have high loadings on a factor and thus enhance the interpretability of the factors. These factors were then employed in the discriminant analysis using a stepwise method of variable selection known as Mahal. In this method the variable that maximizes the Mahalanobis' distance between the two closest groups was selected. The default tolerance level of 0.001 was used with the probability of F-to-enter and the probability of F-to-remove set at 0.05. A detailed statistical account of factor analysis, principal components analysis and other multivariate statistical methods is given in Harris (1975), Green (1979) and Pimentel (1979).

Study Sites

Due to preference of this species for clay substrates, and relative paucity of adults, only three suitable study areas were found in the Thunder Bay district. One site was along the banks of the Kaministiquia River in the Vickers Heights area of the City of Thunder Bay. This

site consisted of steep, exposed and eroding clay banks and precipitous clay cliffs. These intermittent bare slopes, approximately 30 m in height, were the result of much surface water runoff which caused continued slumping of these areas, especially during spring. Trees, shrubs, and grass covered the areas between the exposed clay areas. In some areas, small patches of grass occurred in these exposed areas. Adult specimens were found at all levels of the banks, but primarily within an area 10 m from the water's edge. Most larvae were also found within this area. The principal vegetation consisted of: *Agrostis stolonifera* L., (Redtop); *Aster lateriflorus* (L.), (Calico Aster); *Cirsium arvense* (L.) Scop., (Canada Thistle); *Equisetum arvense* L., (Common Horse Tail); *Populus tremuloides* Michx., (Trembling Aspen); *Prunus virginiana* L., (Choke Cherry); *Salix petiolaris* Sm., (Slender Willow); *Scirpus atrovirens* Willd., (Scirpus); *Solidago canadensis* L., (Canada Goldenrod); *Solidago graminifolia* (L.) Salisb., (Grass-Leaved Goldenrod); *Solidago uliginosa* Nutt., (Marsh Goldenrod); *Vicia americana* Muhl., (American Vetch).

The other two sites were close together in the Rosslyn Village area 5 km west of the Thunder Bay city limits. The larger site consisted of abandoned light brown and grey clay piles in the Rosslyn Brick Yard. These small clay piles were about 3 to 9 m in height and were partially covered by small patches of grass and weeds. The other site was on Hill St., 0.5 km west of the Brick Yard and consisted

of a 3 m deep road side drainage ditch across from a field of pastureland with a few exposed areas of red clay. The principal vegetation of the Brick Yard and the nearby drainage ditch consisted of: *Aster ciliolatus* Lindl., (Ciliate Wood Aster); *Corispermum hyssopifolium* L., (Bugseed); *Lappula echinata* Gilib., (Stickseed); *Matricaria maritima* L. var. *agrestis* (Knaf) Wilmott, (Scentless Chamomile); *Melilotus alba* Desr., (White Sweet Clover); *Salix eriocephala* Michx., (Stiff Willow); *Silene cucubalus* Wibel, (Bladder Campion); *Tragopogon dubius* Scop., (Goat's Beard).

Life Cycle

Larval development of 320 *C. limbalis* larvae was studied at the three aforementioned sites by marking burrows in a manner similar to that used by Mury-Meyer (1983). A golf tee numbered with a waterproof ink marker was placed 2 cm north of each burrow, and the developmental stage noted. As explained by Spanton (1983, 1988) this is simple to observe, since the size of the head and pronotum of the tiger beetle larvae and therefore the diameter of the burrow which it inhabits occur in three discrete size categories corresponding to the three larval instars. Burrows were checked at intervals of a few days to a week throughout the summer. Newly found burrows were marked and each burrow was noted as being open or closed, as this indicated metamorphosing instar larvae, and if open, the instar stage

was recorded.

In the middle to latter half of summer, 1st instar larval burrows began to appear in numbers too large for all to be marked with golf tees. Thus, at this time visual counts were made, over a total combined area of approximately 15 m², of open burrows in each stage of development. This was performed at intervals of a few days to a week to gather further information on the abundance and seasonality of the larval stages, and the time of emergence of the adult.

Although the vegetation in these study sites provided some stability to the areas, erosion was extensive each spring, and many marked tiger beetle larvae were lost due to habitat destruction.

Field Methods and Specimen Preservation

Adult specimens of *C. limbalis* were captured with insect nets in several locations near Thunder Bay, Ontario from June to September 1984 and April to September 1985. Some specimens intended for soft tissue dissection were immediately preserved by placing them in 70% ethanol. Others were separated into small glass vials and brought back to the laboratory. Some of these living specimens were killed by placing them in boiling water. These were pinned and labeled for permanent storage. The other living specimens were used for mating and rearing experiments. Larvae were collected in one of two ways. The "lie in wait" method involved waiting

near the mouth of an open larval burrow until the larva appeared near the surface and then trapping it at the top of its burrow by rapidly driving a shovel beneath it cutting off its escape route. However, because of the density of clay it was not always possible to drive a shovel into it to trap the larva. Therefore, the second and more successful method used was to dig out the larvae within large blocks of clay using a large garden spade, and to break open the clay block by hand, thus exposing the larva within its burrow chamber. This method also allowed one to examine the shape of the burrow and its length. All larvae were placed alive in small glass vials with a small amount of soil for transport back to the laboratory. From these larvae, samples representing each of the three instars were selected to be preserved for permanent storage. They were boiled in water for approximately five minutes to preserve their colour and then placed in 70% ethanol. The other instars were used in the rearing experiments. Samples of clay were collected from each of the study areas, to be used in terraria and larval rearing tubes.

Laboratory Conditions and Rearing Techniques

The laboratory conditions were described in Part A. In some of the terraria a clay substrate was provided which sloped from a depth of 8 cm to 1 cm across half the width of the terrarium. Any eggs laid in this clay were allowed to develop into 1st and 2nd instar larvae. In other terraria,

petri dishes of clay were provided for oviposition. These oviposition dishes were checked periodically for eggs by visual inspection of the underside of the petri dish where eggs would be attached or by crumbling the soil gently with forceps and teasing needles as suggested by Palmer (1979). Five eggs recovered in this manner were examined, measured and preserved in 70% ethanol.

First instar larvae which appeared in the terraria subsequent to mating and oviposition, as well as 2nd instar larvae which were allowed to develop in the terraria and other instar larvae dug from the field were reared in glass tubes approximately 2 cm in diameter by 30 cm long in a manner similar to that described by Palmer (1979). The rearing tubes were plugged at the bottom with a soft foam material or cotton balls and filled to a depth of 25 cm with moist clay from the site where the larvae were collected, or in the case of those produced in the laboratory, where their parents were collected. A wooden dowel of slightly smaller diameter than the glass tube was used to pack the moist clay. Long metal rods were used to make holes in the clay; the diameter being the same as, or slightly larger than, burrows in nature. The larvae were then transferred in a manner described by Palmer (1979). The rearing tubes were stood on end in a plastic bucket and the clay kept slightly moist with water added to the bucket and occasionally applied to the surface with a plant sprayer. Although soil moisture was

carefully regulated to minimize fungal growth, several specimens were lost because of fungus. First instar larvae were fed early instar larvae of *Tribolium* sp. whereas 2nd and 3rd instar tiger beetle larvae were fed late instar, pupae and adult *Tribolium* sp. Several laboratory hatched and reared larvae of each instar were preserved in the same manner as those collected in the field. Larvae were removed from their tubes by first soaking the tubes under water for 30 minutes and then forcing out the sticky clay using a wood dowel as a plunger. Care was taken not to crush larvae while searching through each clay cylinder.

Genitalia of the *Cicindela splendida* Group

The genitalia of male and female specimens of widely distributed populations of *C. splendida*, *C. limbalis* and *C. denverensis* were examined for structures of taxonomic importance. At least five males and five females were examined for each population. Drawings were prepared from these specimens.

To study the genitalia, beetles were softened in hot water. The genitalia of both sexes were dissected in a manner similar to that described by Freitag (1965, 1966, 1972, 1979). Male genitalia to be drawn were cleared with clove oil as described by Martin (1978). The internal sac of the aedeagus was manually everted by either using pressure applied with fine forceps or by means of a #1 insect pin with

a hooked point. Drawings were prepared with the use of a drawing tube attached to a Wild M5 stereoscopic microscope.

Soil Associations

Collecting localities taken from specimen label data were located as accurately as possible on soil maps to determine relationships between distribution of dominant soil types at the order, great group and subgroup level of soil classification and the distribution of the three species of the *C. splendida* group in North America (Tables 4 to 6). For this purpose national scale maps were used (Soils of Canada, 1972; USDI, 1970). The Canadian system of soil classification as presented by Clayton et al. (1977) was followed. Conversions between the United States and Canadian systems of soil classification were made as accurately as possible with tables provided in Armson (1977), Clayton et al. (1977) and FitzPatrick (1980). Descriptions of soil types were taken from Clayton et al. (1977) for the Canadian classification and from the Soil Survey Staff (1960, 1967) for the American system.

Seasonality and Distribution

Dates of collection were recorded from specimen labels and used to plot histograms of frequency of capture versus date to investigate seasonality of adults of the three species. Label data were also used for compiling

distribution lists and for plotting distribution maps.

Criteria for Species and Subspecies

Species concepts have been discussed by Simpson (1961), Mayr (1969, 1970, 1982b), Ross (1974) and Wiley (1981), among many others. The use of a subspecific category is controversial. Scientists such as Edwards (1954), Mayr (1954, 1982a), Durrant (1955), Parkes (1955, 1982) and Smith and White (1956) argue in favour of the concept whereas Wilson and Brown (1953), Gosline (1954), Hubbell (1954) and Owen (1963) among others, are opposed to it.

Formal naming of minutely different populations has little meaning biologically, and confuses subsequent workers. Formerly, in tiger beetle taxonomy, many species and subspecies names were proposed, based on a few variant specimens. As indicated by Spanton (1988) other concerns regarding subspecies include the following: (1) the tendency for different characters to show discordant patterns of geographic variation; (2) the occurrence of similar or phenotypically indistinguishable populations in geographically separated areas (the "polytopic subspecies" of Mayr, 1969); (3) that an artificial compartmentalization of our concept of the pattern of variation in a species tends to obscure geographic variation within subspecies; and (4) the subjectivity in the degree of distinction required by different workers to justify the application of a formal

name.

Combined with breeding experiments, relationships between phena in this study were inferred, based on holomorphological evidence with emphasis on adult structure and supplemented with some ecological and distributional data. Recognition of subspecies follows the system of Freitag (1965) and Spanton (1983, 1988). Sympatric forms which show little or no intergradation in at least one character are considered specifically distinct. Allopatric forms which intergrade clinally over a fairly wide zone of contact are considered subspecies if the forms are sufficiently different structurally. Allopatric populations are considered subspecies if they differ only in colour or colour pattern.

RESULTS AND DISCUSSION

Eggs and Larvae of *Cicindela limbalis*

I found that under laboratory conditions females of *C. limbalis* laid eggs only in moist, rough, steep clay; a finding which supports that of Shelford (1907, 1908). Five eggs of *C. limbalis* removed from clay in petri dishes shortly after oviposition had a shiny transparent chorion and a creamy coloured yolk which appeared homogeneous. The eggs were oblong and had one end slightly wider than the other. The narrower end of the egg was sticky and was covered by adherent clay particles. The eggs ranged in size from 1.92

mm to 2.31 mm in length, the average being 2.1 mm and from 0.94 mm to 1.21 mm in width at their widest point, the average being 1.1 mm. No eggs of either *C. splendida* or *C. denverensis* were recovered from the soil.

Published descriptions indicated that cicindelid eggs are similar and lack any obvious differences other than size, with the larger beetles usually having larger eggs. Willis (1967) observed, at high magnification, a fine reticulate pattern of the shiny surface of the chorion of the egg of *C. togata* LaFerté. Moore (1906), Huie (1915), Zikan (1929) and Willis (1967) noted that the eggs of *Cicindela* are sticky at one end or are fastened to the substrate by a short stalk.

I was unable to obtain or rear larvae of either *C. splendida* or *C. denverensis*. I reared larvae of *C. limbalis*; however, the detailed descriptions provided by Hamilton (1925) are adequate.

Life Cycle

Three temporal variations of the basic cicindelid life cycle for different species of *Cicindela* occurring in the vicinity of Chicago, Illinois have been given by Shelford (1908).

1. A one year cycle (larval life approximately 10 months, adult life approximately two months) is exhibited by *C. punctulata* Olivier. Eggs are laid in mid-summer and

larvae usually attain 3rd instar by fall, hibernate and pupate the following June. Adults emerge in early July rapidly reach sexual maturity, mate and die within 2 months.

2. A two year cycle (larval life approximately 21 months, adult life approximately two months) is exhibited by *C. lepida* Dejean. Eggs are laid in mid-summer and larvae usually attain 2nd instar by fall, and then hibernate. These larvae reach the 3rd instar early in the second summer, hibernate again, and pupate the following May. Adults emerge early in the third summer, rapidly reach sexual maturity, mate and die within two or three months.

3. A two year cycle (larval life approximately 12-13 months, adult life approximately 10 months) is exhibited by *C. purpurea*. Eggs are laid in late spring and early summer and larvae usually attain 3rd instar by fall, hibernate, and pupate the following summer. Adults emerge in early fall, hibernate the second winter, and become sexually mature late in the third spring. Thus, adult life is approximately 10 months.

The life history of *C. limbalis* in Chicago, Illinois was first described by Shelford (1908), in which he indicated that the larval stage lasts about 14 months and the adult stage 10 months. Criddle (1910) compared this study to his study of the life cycle of *C. limbalis* at Aweme (now Treesbank), Manitoba, and noted a prolongation of the larval life over a second winter in Manitoba. Thus, he stated that

the life cycle of *C. limbalis* lasts for approximately three years: duration of larval stage, 24 to 26 months; pupal, two to four weeks; adult, 10 to 12 months. The three instar larvae of *C. limbalis* were described in detail by Hamilton (1925). The life history and larval morphology of *C. splendida* and *C. denverensis* have not been described.

Shelford (1908) states that although the 1st larval stage usually lasts a little more than one month, the other stages vary greatly in different species and that the length of different stages is influenced by temperature, moisture and food. Willis (1967) noted that one meal of "sufficient size" promoted molting in 1st instar larvae. The work of Palmer (1976, 1978), Palmer and Gorrick (1979) and Hori (1982) indicated that developmental times and variance in stadium length are significantly reduced if larvae are provided with supplemental food and that attainment of a threshold body mass was the necessary and sufficient condition to allow for molting to the next stage. In the laboratory some species have been reared from egg to adult in as little as 60 days (Knisley and Pearson, 1984). The work of Mury-Meyer (1983) supports the premise that larval nutritional status influences the timing of both instar diapause and pupation.

The observation of larval development of 320 marked *C. limbalis* larvae located throughout the three study sites, revealed a chronology similar to that observed by Spanton

(1983, 1988) for the tiger beetle *C. longilabris* Say, at Stanley Hill, near Thunder Bay, Ontario (Fig. 42).

First instar larvae appeared toward the end of June 1984 and were found with increased frequency throughout July and early August 1984. Many larvae were not followed through to the end of summer due to either natural mortality, or to destruction of their clay habitat by erosion. Larvae which were successfully followed through the summer had attained the 2nd instar stage by the second week of August 1984 and overwintered in this stage. Six 1st instar larvae were found in late August 1984 and probably overwintered in this stage.

Although many 2nd instar larvae perished during the overwintering period, or were lost in spring floods, most that survived, attained 3rd instar stage by the first week of June 1985.

Most 3rd instar larvae closed their burrows in mid-July 1986 to pupate, and emerged as adults by mid-August 1986. These adults overwintered and laid eggs during the later half of May 1987 and most of June 1987. However, about 15 3rd instar larvae were found in mid-September 1986 and probably overwintered in this stage. Thus, the life cycle of *C. limbalis* in Thunder Bay, Ontario lasts for approximately three years: duration of larval stage, 24 months; pupal stage, 1 month; adult stage, 10 months.

Under laboratory conditions each larval stage molted to the next stage approximately two to three weeks

faster than the corresponding stage found in the study sites. Thus, the prolongation of larval life over a second winter in Manitoba and northern Ontario is probably caused by shorter summer seasons which limit total food intake and delay progress through the larval stages.

The monthly ratio of males to females of all adults of *C. limbalis* captured in each of the two study sites during the two years of the study period is given in Table 3 and Figs. 43 to 46. These data suggest that males outnumbered females early in the season, but that females were more numerous late in the season. This finding is consistent with that of Spanton (1983, 1988) for *C. longilabris* but is the reverse of that found by Freitag (1965) for the tiger beetles *C. duodecimguttata* Dejean and *C. oregona* LeConte. Spanton (1983, 1988) suggested that the ratios he obtained may not be indicative of the actual male to female ratio for the species because as noted by Kaulbars (1982) behavioural differences such as predominance of males in open foraging areas during breeding season and females ovipositing in sites outside the foraging areas, may bias observed ratios. Although the same reasoning may apply to *C. limbalis* as well, I have observed this pattern of greater male abundance during early season in several species in this region and believe that the males probably emerge first in readiness for emerging females. It appears that at the time of emergence sexual maturation is complete for both sexes, and that females are sexually

receptive to males.

In the natural setting, pairs of *C. limbalis* were observed copulating during late April through to early July. The fact that no mating pairs were seen after July 7th or at any time during August or September is consistent with the hypothesis that most adults emerging in late summer do not reach sexual maturity until the following spring. However, Hori (1982), in studying the tiger beetle *C. japonica* (Thunberg), which exhibited seasonality of the adult stage similar to that for *C. longilabris* studied by Spanton (1983, 1988) and for *C. limbalis* as found in this study, indicated that a small number of the adults emerging in late summer achieve sexual maturity quickly and limited oviposition occurs in late summer and early fall. This would account for the small number of slow developing *C. limbalis* larvae. Also, the fact that *C. limbalis* exhibits some variability in the timing of appearance of the life stages, is consistent with the findings for many species studied by previous authors (Shelford, 1908; Willis, 1967; Palmer, 1976; Spanton, 1983, 1988). As noted by Spanton (1983, 1988) if the chronology of the life cycle were rigid for all individuals the species would consist of three distinct populations each genetically and temporally isolated from the other two. However, presence of slow developing larvae and a small number of late season matings would maintain a genetic connection between year classes. Also, staggered development

would safeguard against population extinction by unpredictable catastrophes due to seasonal events.

Collection dates of adult specimens of *C. limbalis*, *C. splendida* and *C. denverensis* are presented in Figs. 47 to 49 respectively. All three can be described as spring-fall species which depict a bimodal frequency curve. The greatest number of adults are found during spring, when mating occurs, and during fall, when teneral forms emerge before overwintering. Most spring adults have mated and died by summer, leaving behind the developing larvae and few adults that emerged and mated late during spring. Also, a few teneral forms may emerge during late summer or early fall. Deviations from the bimodal pattern can result because: (1) most insect collectors are more active in temperate climates during summer months; (2) with sufficient numbers of collectors in the field, specimens will be collected even if their abundance is low; (3) collectors may collect only a few specimens or many specimens regardless of abundance; and (4) collectors may collect only a particular species regardless of those that can be collected at the same time and place. However, despite these possible weaknesses in the data, general trends were still observed.

Population peaks for *C. limbalis* in Canada occurred in the second half of June and August. In the northeastern United States *C. limbalis* populations peaked in the second half of May and August. In the northcentral United States *C.*

limbalis populations peaked in the second half of May and the first half of September. In the northwestern United States *C. limbalis* populations did not clearly exhibit the typical bimodal pattern, showing an obvious peak which occurred in the second half of June and a small peak in the second half of September. In the southeastern United States *C. limbalis* populations peaked in the first half of May and September whereas in the southcentral United States they peaked in the second half of June and September. These patterns suggests that although adult emergence and seasonal abundance is similar throughout the range of *C. limbalis*, northern populations peak later during spring probably because of a later spring emergence in a colder climate. Also, *C. limbalis* adults are less prevalent during late fall in the northern areas due to colder days and frosty nights.

Population peaks for *C. splendida* in northcentral United States occurred in April and the first half of October whereas in the northeastern United States populations peaked in the first half of May and September. In the southcentral United States *C. splendida* populations peaked in the second half of March and the first half of October whereas in the southeastern United States they peaked in the first half of April and the second half of September. These patterns of adult abundance shows that northern populations of *C. splendida* peak later during spring than southern populations and that they peak earlier during spring than do populations

of *C. limbalis* in the same areas.

Population peaks for *C. denverensis* in northwestern United States occurred in the second half of May and early September while in the northcentral United States populations peaked in the second half of both May and September. In the southcentral United States *C. denverensis* populations did not clearly exhibit the typical bimodal pattern, showing only the first peak which occurred during early April.

A summary of the seasonality of the populations of these species shows that the most northern species, *i.e.*, *C. limbalis*, emerges later during spring than does the next most northern species, *i.e.*, *C. denverensis*, and that both of these species emerge later than *C. splendida* which is the most southernly ranging species. However, despite differences in time of peak abundance, all three species overlap in time and space, thus excluding these factors as species isolating mechanisms.

Fig. 42. Life cycle of *C. limbalis* compared with those of other species of *Cicindela* studied by Geoffroy (1762), Westwood (1831), Blisson (1848), Enock (1903), Criddle (1907, 1910), Shelford (1908), Huie (1915), Hamilton (1925) and Spanton (1983, 1988).

The exact time of appearance and duration of larval stages varies geographically and from year to year.

..... egg
 _____ 1st instar larva
 ▭ 2nd instar larva
 ▭▭ 3rd instar larva
 ▭▭▭▭▭ pupa
 ▭▭▭▭▭▭▭▭▭▭ adult

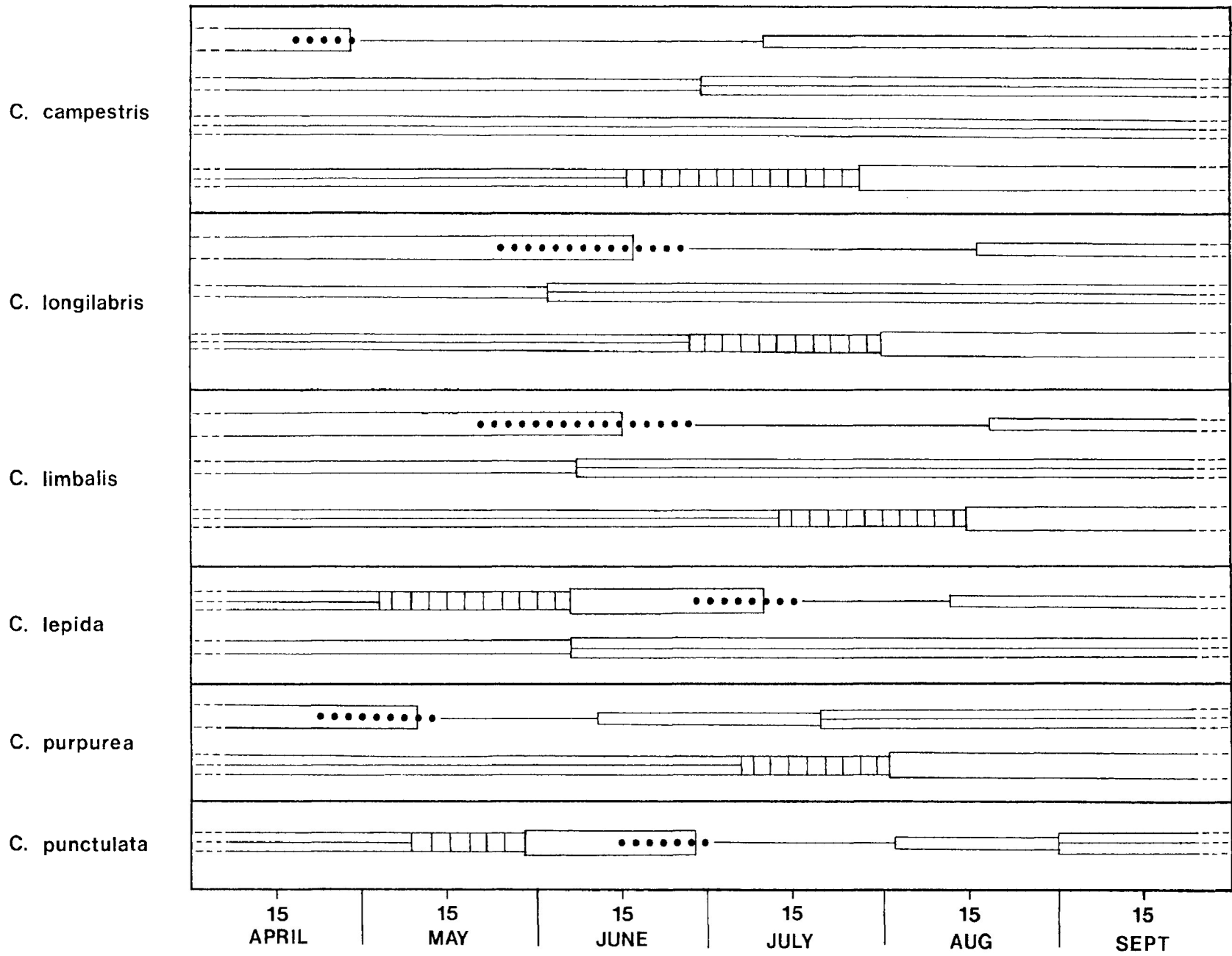

Table 3. Ratio of males to females captured in the two study sites during two consecutive field seasons.

LOCATION	YEAR	APRIL	MAY	JUNE	JULY	AUG	SEPT	TOTAL
Kaministiquia River	1984	no data	no data	37/18 2.1:1	3/6 1:2	41/46 1:1.1	13/15 1:1.2	179
	1985	12/8 1.5:1	14/13 1.1:1	19/36 1:1.9	15/28 1:1.9	no data	no data	145
Rosslyn Brick Yard	1984	no data	no data	4/5 1:1.25	13/9 1.4:1	28/40 1:1.4	12/4 3:1	115
	1985	1/0 1:0	5/12 1:2.4	20/16 1.25:1	39/34 1.1:1	17/26 1:1.5	13/7 1.9:1	190

Fig. 43. Total catch of adults of *C. limbalis* at the Kaministiquia River site during the 1984 field season (June to September).

A. males
B. females

Fig. 44. Total catch of adults of *C. limbalis* at the Kaministiquia River site during the 1985 field season (April to July).

A. males
B. females

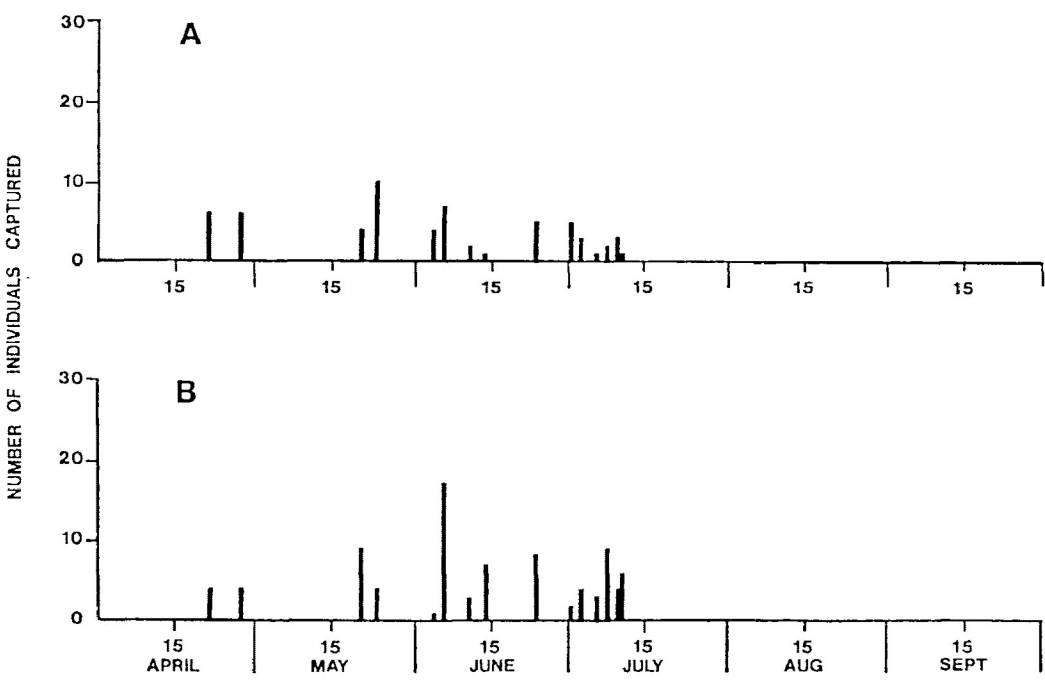
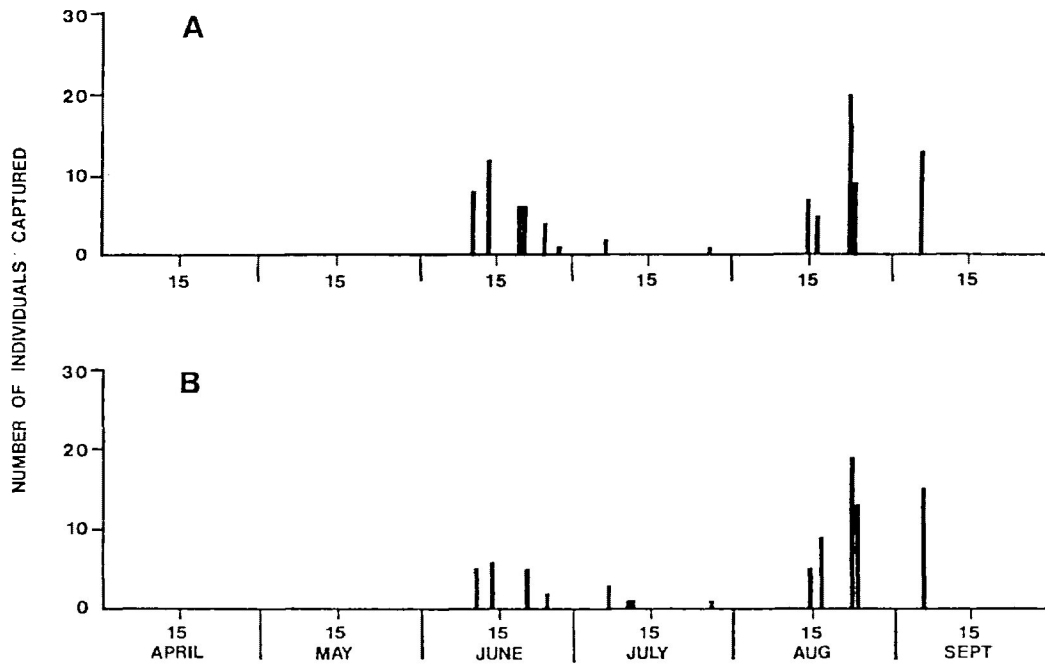

Fig. 45. Total catch of adults of *C. limbalis* at the Rosslyn Brick Yard site during the 1984 field season (June to September).

- A. males
- B. females

Fig. 46. Total catch of adults of *C. limbalis* at the Rosslyn Brick Yard site during the 1985 field season (April to September).

- A. males
- B. females

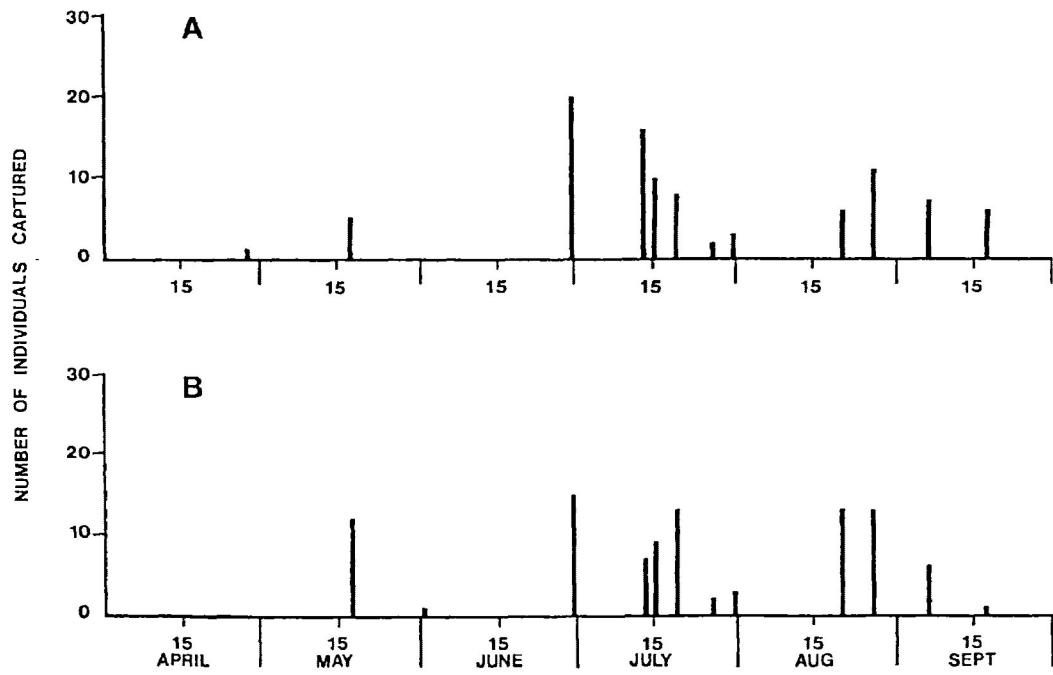
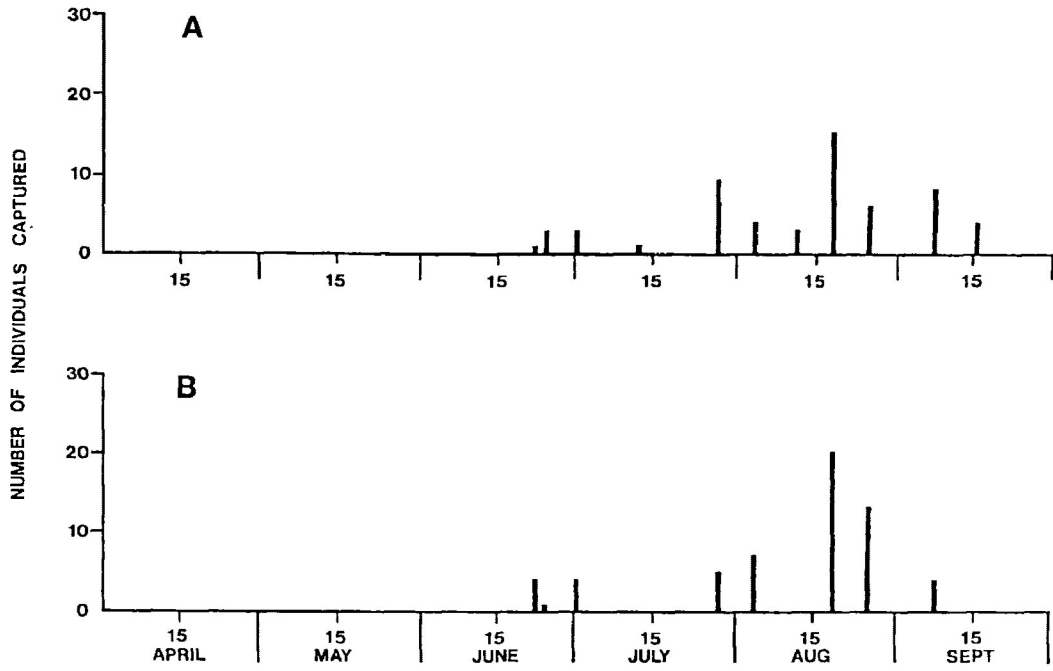

Fig. 47. Collection dates of adult specimens of *C. limbalis*.

- A. Canada (Nova Scotia, New Brunswick, Quebec, Ontario, Manitoba, Saskatchewan, Alberta, British Columbia, Northwest Territories)
- B. Northeastern United States (Maine, New Hampshire, Vermont, Massachusetts, Connecticut, New York, New Jersey, Pennsylvania, Ohio, Michigan)
- C. Southeastern United States (West Virginia, Virginia, North Carolina, South Carolina)
- D. Northcentral United States (North Dakota, South Dakota, Nebraska, Iowa, Minnesota, Wisconsin)
- E. Southcentral United States (Colorado, New Mexico, Kansas, Oklahoma, Arkansas, Missouri, Illinois)
- F. Northwestern United States (Washington, Montana, Wyoming, Utah)

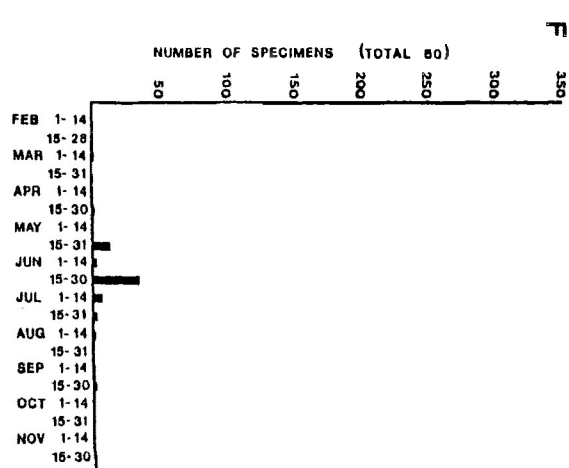
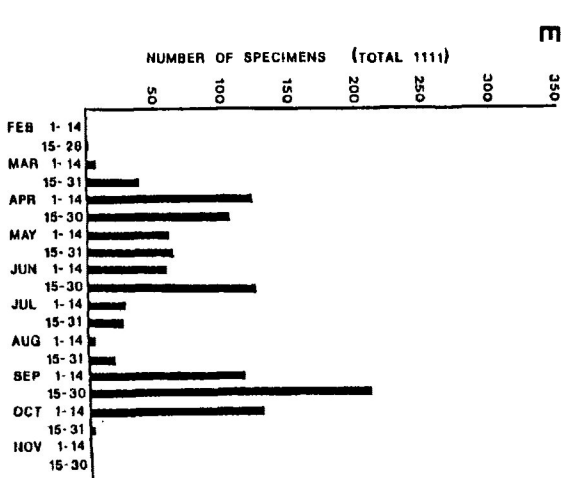
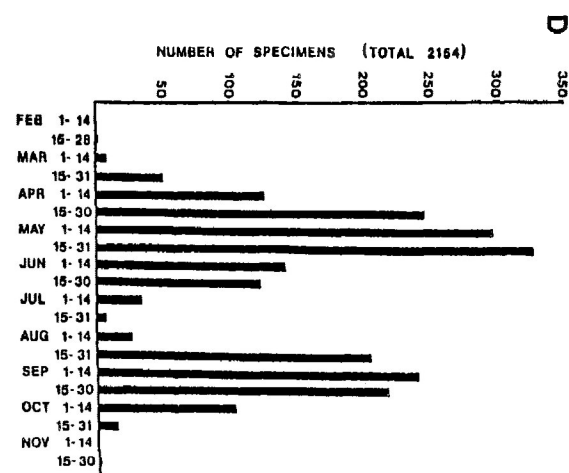
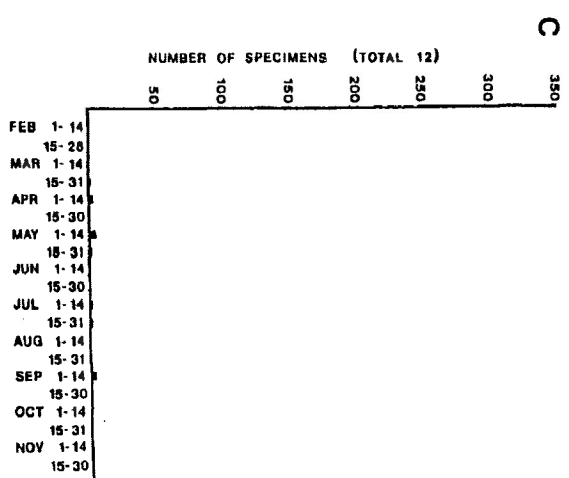
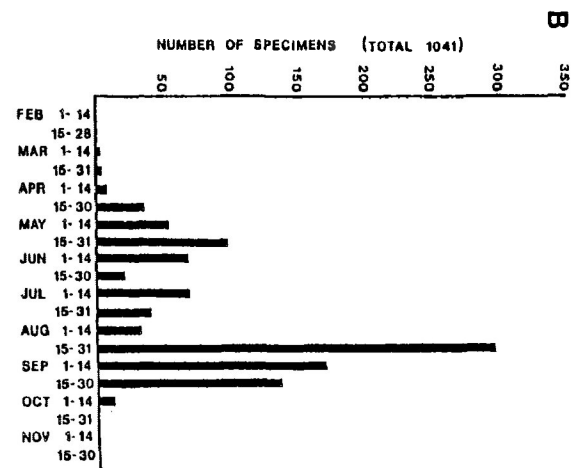
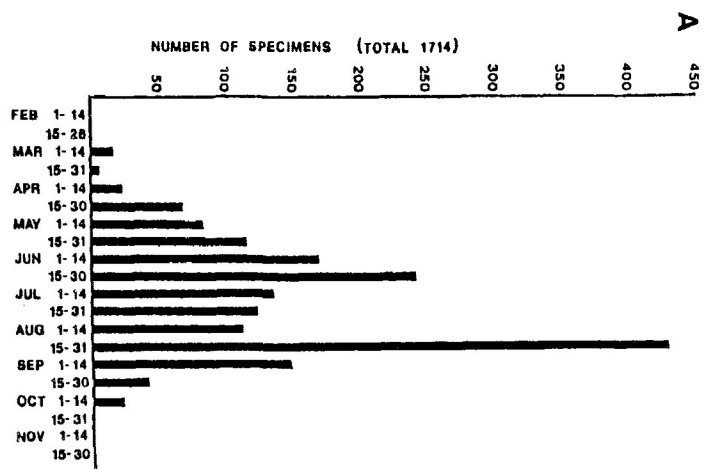

Fig. 48. Collection dates of adult specimens of
C. splendida.

- A. Northcentral United States (Nebraska, Iowa, Minnesota, Wisconsin)
- B. Southcentral United States (Colorado, New Mexico, Kansas, Oklahoma, Texas, Louisiana, Arkansas, Missouri, Illinois)
- C. Northeastern United States (Ohio, Maryland, District of Columbia)
- D. Southeastern United States (Virginia, North Carolina, South Carolina, Georgia, Kentucky, Tennessee)

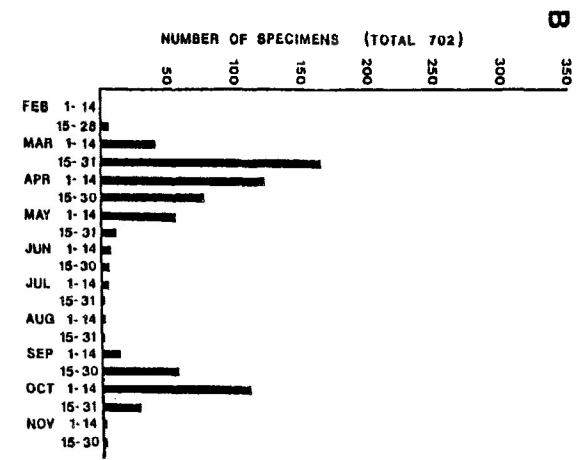
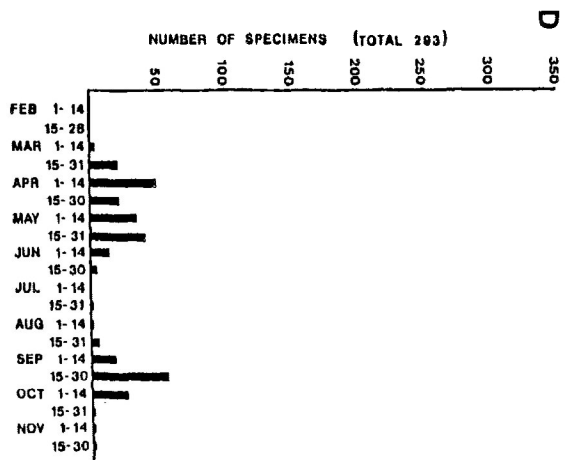
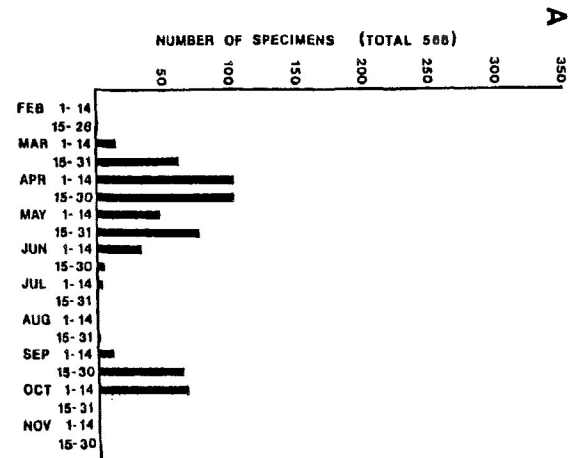
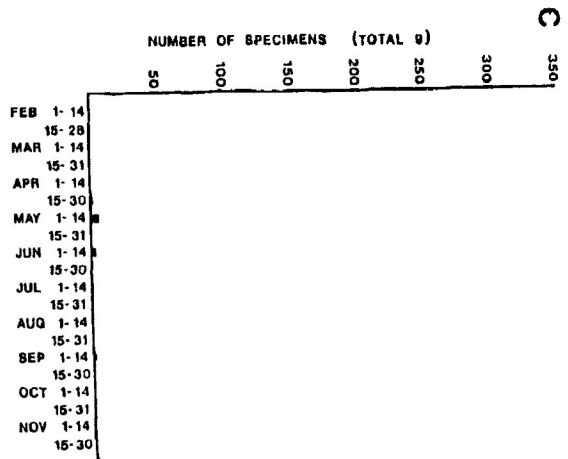
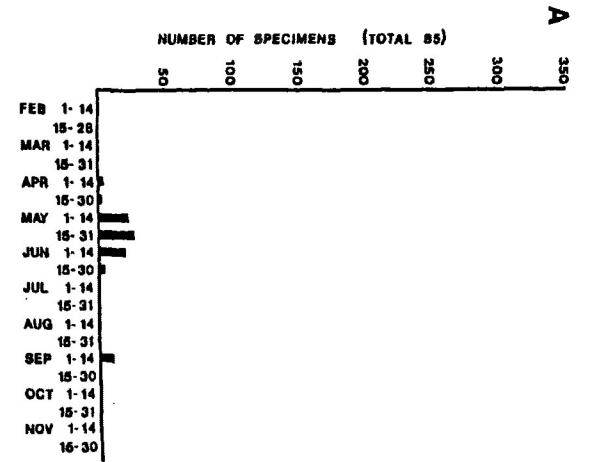
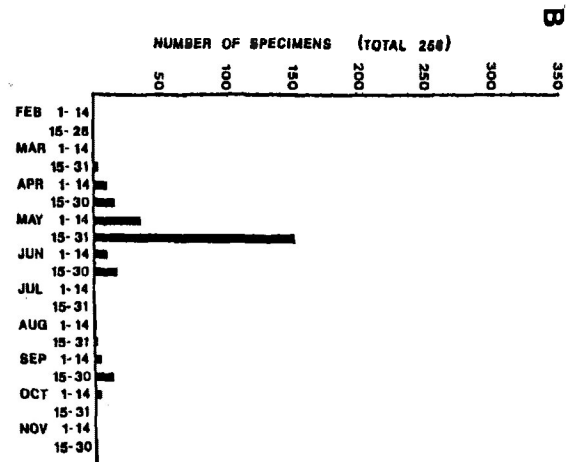
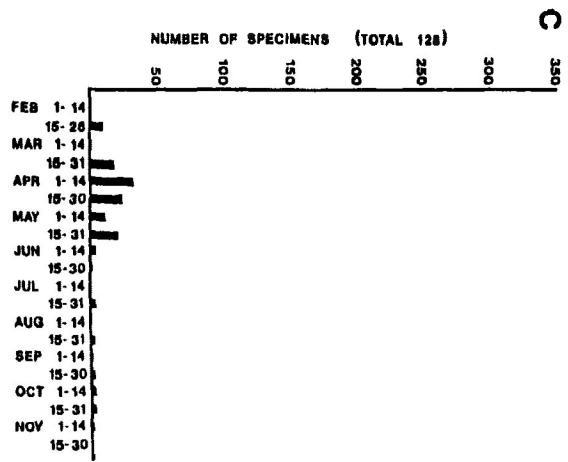

Fig. 49. Collection dates of adult specimens of
C. denverensis.

- A. Northwestern United States (Montana, Wyoming)
- B. Northcentral United States (North Dakota, South Dakota, Nebraska)
- C. Southcentral United States (Colorado, New Mexico, Kansas, Oklahoma, Texas, Arkansas)



Genitalia of the *Cicindela splendida* Group

Figures 50 to 73 show genitalia of male and female specimens of widely distributed populations of each of the species. The nomenclature follows that of Freitag et al. (1985).

Measurements of male genitalia of 20 specimens from each species indicated that the aedeagus of *C. denverensis* was slightly longer than that of *C. splendida* which in turn was slightly longer than that of *C. limbalis*. The sclerites of the internal sac appeared similar in all three species. The tooth in *C. denverensis* appeared wider and its tip slightly more skewed than that in the other species, and the flagellum of *C. denverensis* seemed slightly shorter and more tightly curved at the base than that of the other species. These observations corroborate those of Rumpff (1980). Exact measurements of the flagellum were not obtained because this coiled sclerite broke while being spread out.

Examination of 20 females of each of the species revealed the similar size relationships as did the males. Although exact measurement of the spermathecal duct was not obtained, because of breakage during dissection or deterioration of samples, apparently the spermathecal duct length corresponds to the length of the male flagellum. Females of *C. denverensis* possessed a shorter spermathecal duct which corresponded to the shorter flagellum of the male.

The three species appear very similar; however,

C. splendida and *C. limbalis* are more like each other than *C. denverensis*. Also, the results of mating behavioural studies between *C. splendida* and *C. limbalis* suggests that mechanical isolation due to genitalic incompatibility is not present between these species. Since all three species have similar genitalia, presumably they can mate and transfer a spermatophore. Even the successful transfer of a spermatophore however, does not rule out the possibility of species separation at some subsequent stage of reproduction. Since very few hybrids are known for these three species and since premating isolating mechanisms described by Mayr (1970) such as seasonal and habitat isolation, ethological isolation and mechanical isolation are not apparent, then postmating isolating mechanisms are probably responsible for maintaining species identity. The ejection of the spermatophore by the female, as mentioned in Part A, may represent a postcopulatory isolating mechanism which maintains species identity. As a result of spermatophore ejection by the female, it is probable that no eggs were fertilized but because no eggs were retrieved from interspecific matings, the role of postmating mechanisms in species isolation was not determined.

Fig. 50-61. Features of the male tiger beetle genitalia:

ap = arciform piece
bo = basal orifice
bp = basal piece
cp = central plate
f = flagellum
laf = lateral apical flange
p = parameres
t = tooth
sh = shield
ssr = small stiffening rib

Fig. 50-53. Aedeagus, ventral and left lateral aspects, and sclerites of the internal sac of *C. splendida* from Hope, Arkansas (Fig. 50), Asheville, North Carolina (Fig. 51), Osceola, Nebraska (Fig. 52) and Mount Vernon, Virginia (Fig. 53).

50

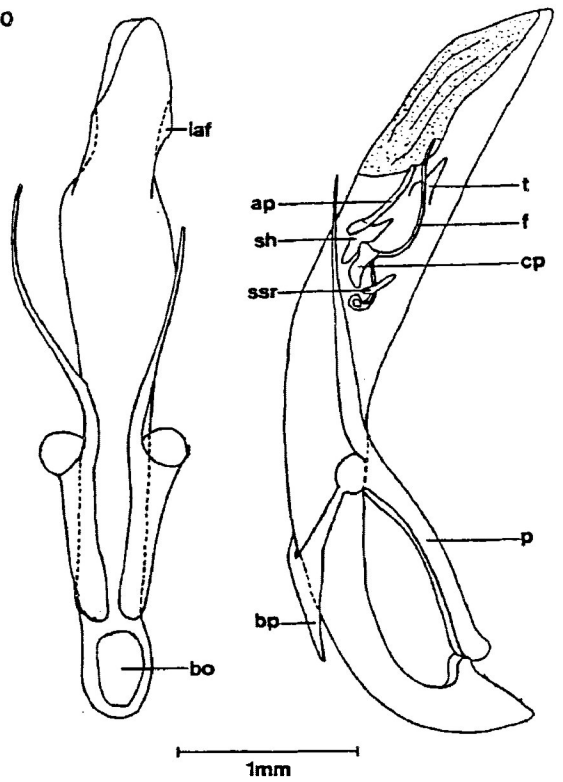

51

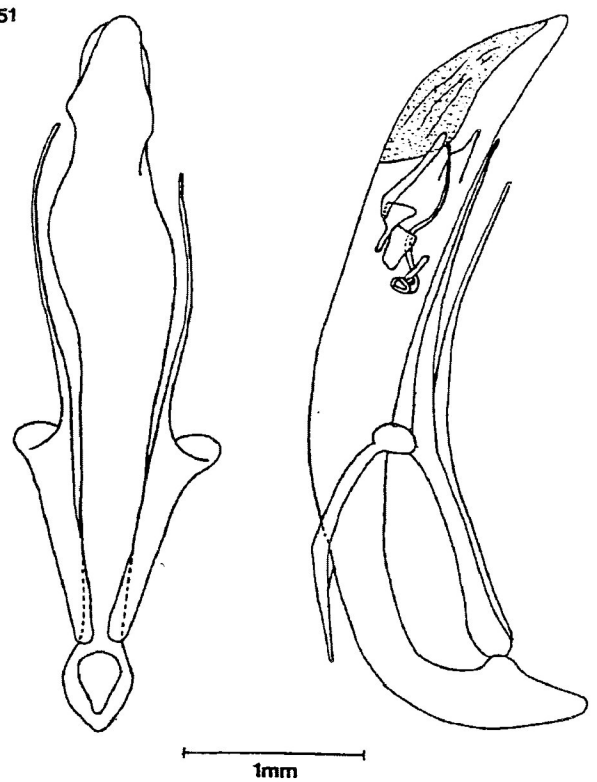

52

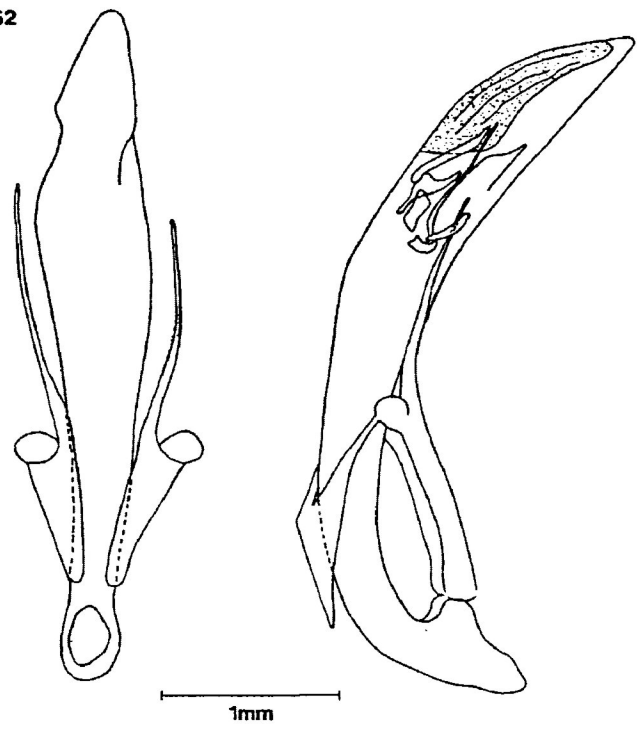

53

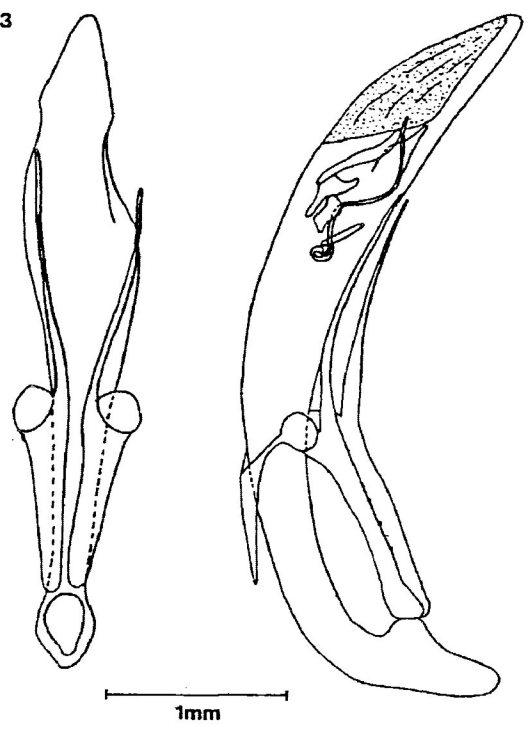
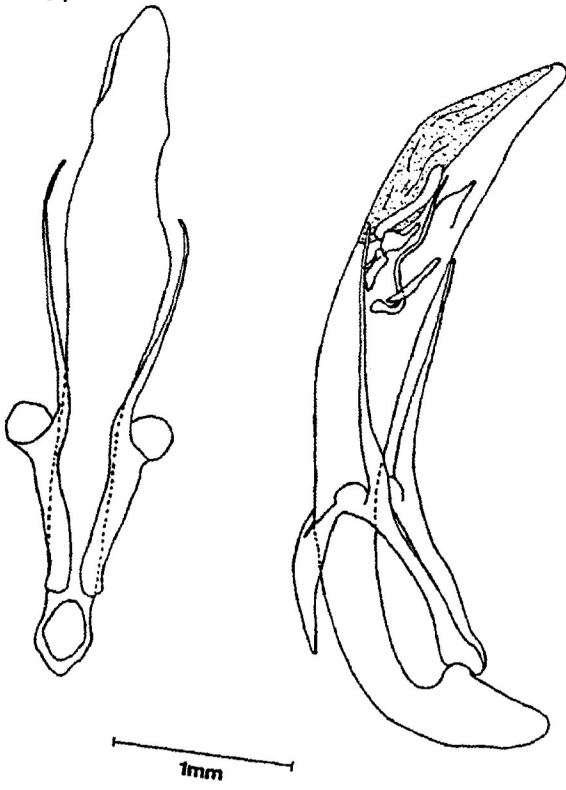
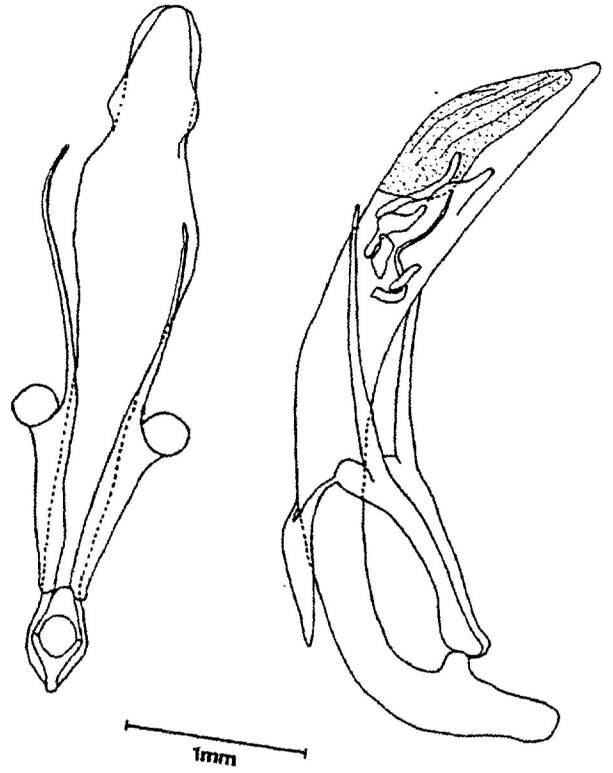

Fig. 54-57. Aedeagus, ventral and left lateral aspects, and sclerites of the internal sac of *C. limbalis* from Osceola, Nebraska (Fig. 54), Greenwood Lake, New Jersey (Fig. 55), Norman Wells, Northwest Territories (Fig. 56) and Thunder Bay, Ontario (Fig. 57).

54



55



56

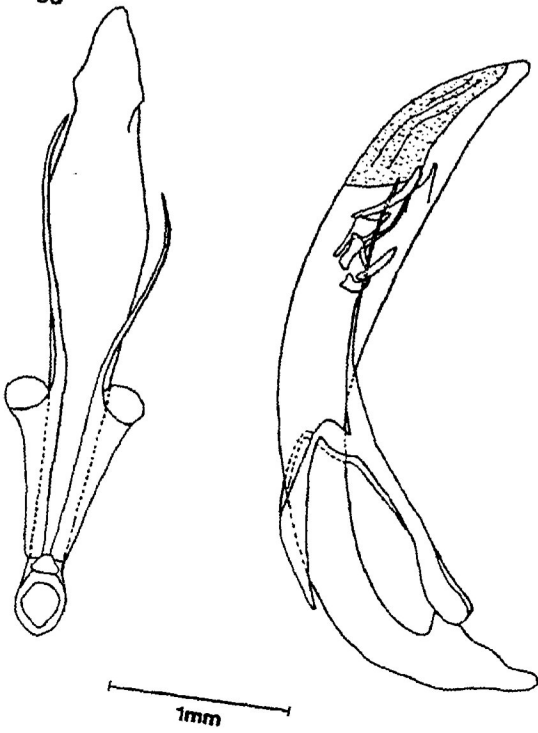

57

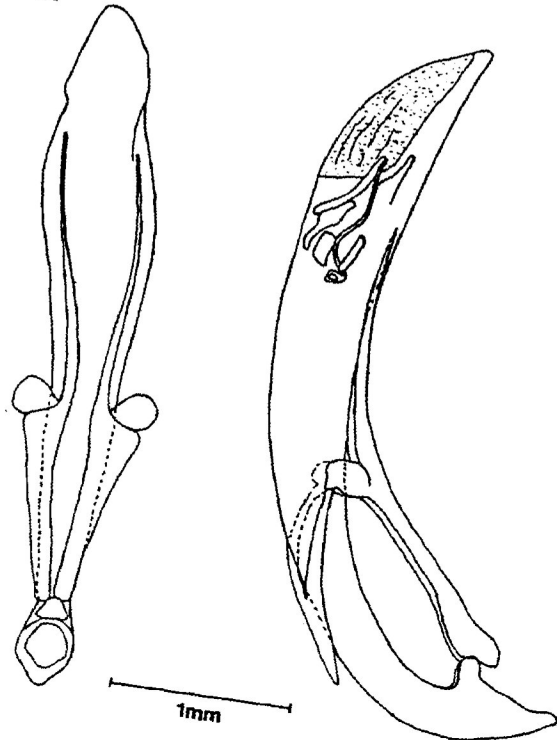
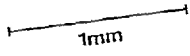
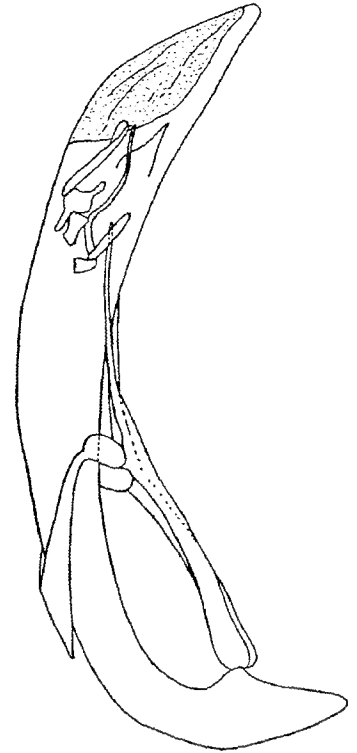
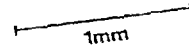
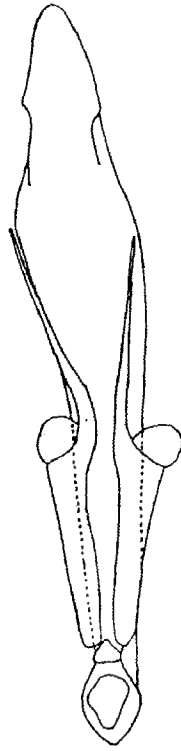
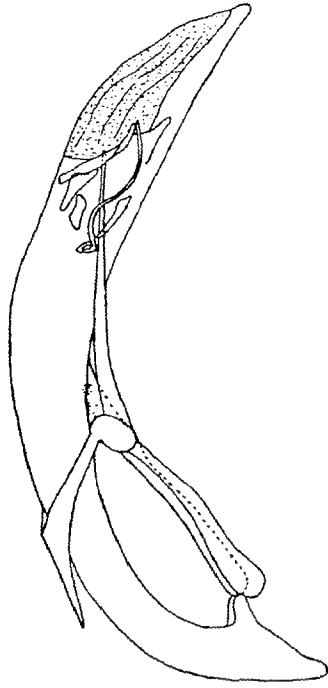

Fig. 58-61. Aedeagus, ventral and left lateral aspects, and sclerites of the internal sac of *C. denverensis* from Denver, Colorado (Fig. 58), Dunn County, North Dakota (Fig. 59), Benkelman, Nebraska (Fig. 60) and Lawrence, Kansas (Fig. 61).

58



59



60

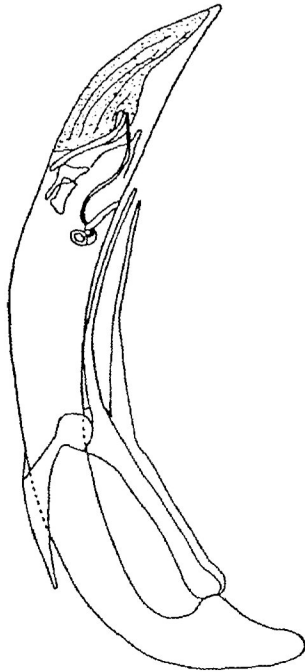
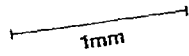
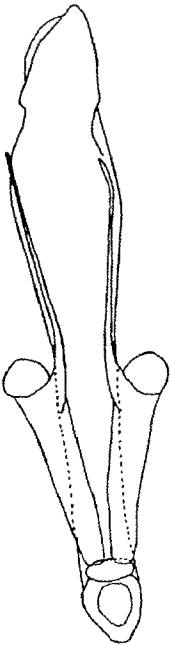

61

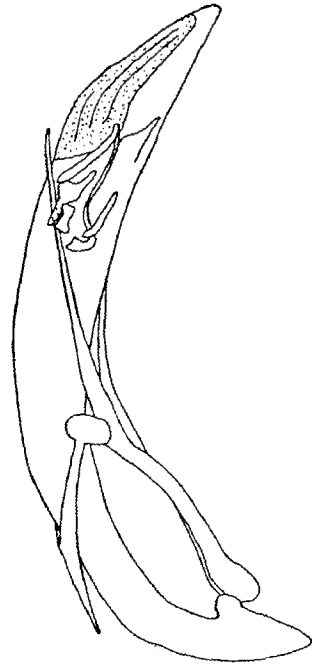
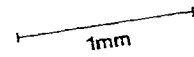
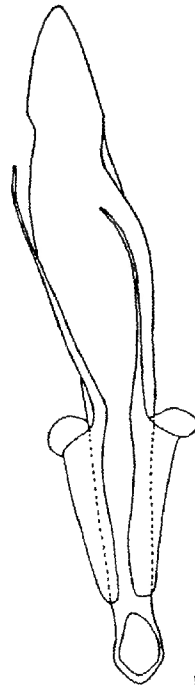
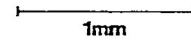
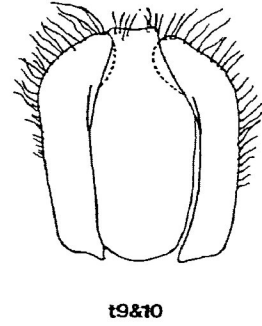
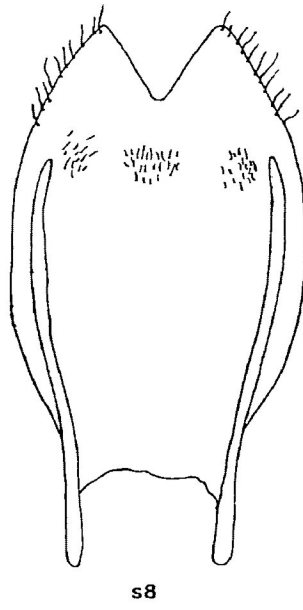
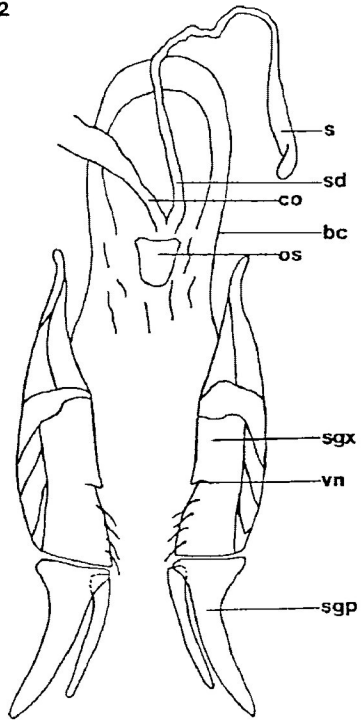

Fig. 62-73. Features of the female tiger beetle genitalia:

bc = bursa copulatrix
co = common oviduct
os = oviduct sclerite
s8 = sternum 8
s = spermatheca
sd = spermathecal duct
sgp = second gonapophysis
sgx = second gonocoxa
t9&10 = syntergum 9&10
vn = ventral notch of second gonocoxa

Fig. 62-63. Female genitalia of *C. splendida* from Hope, Arkansas (Fig. 62) and Asheville, North Carolina (Fig. 63).

62



63

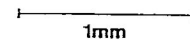
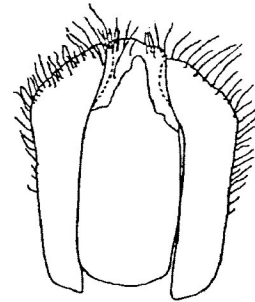
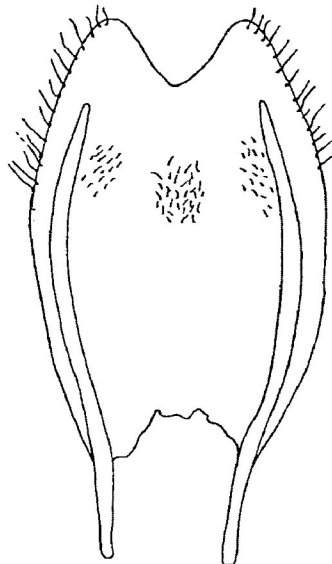
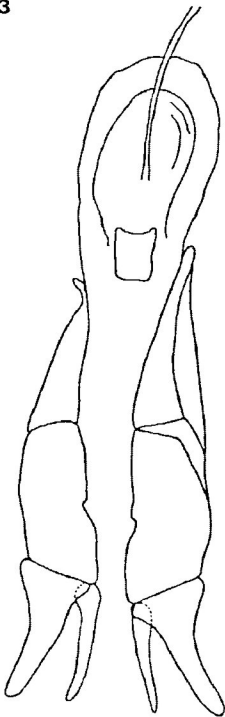
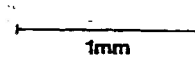
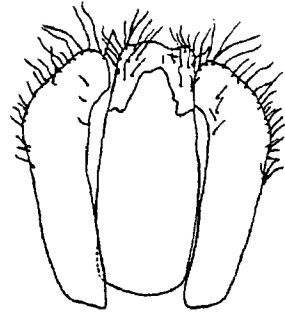
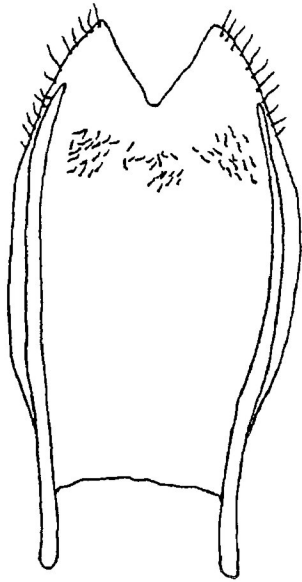
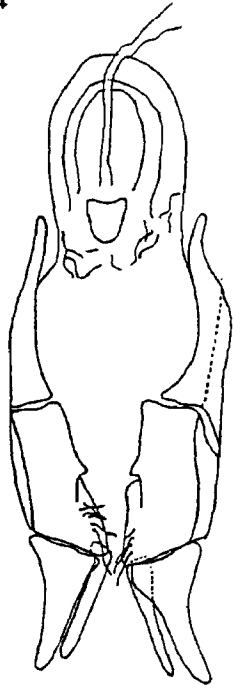

Fig. 64-65. Female genitalia of *C. splendida* from Osceola, Nebraska (Fig. 64) and Mount Vernon, Virginia (Fig. 65).

64



65

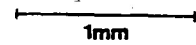
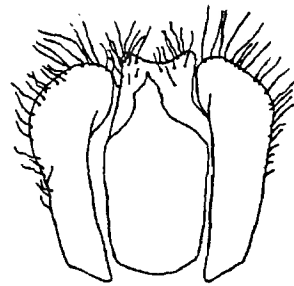
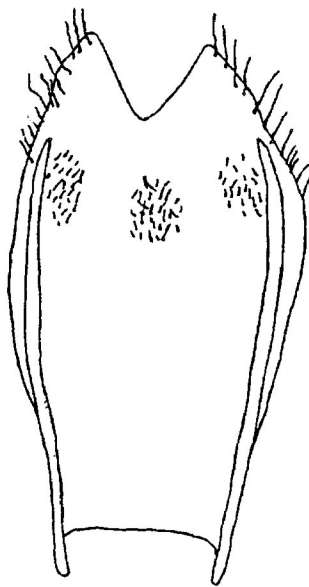
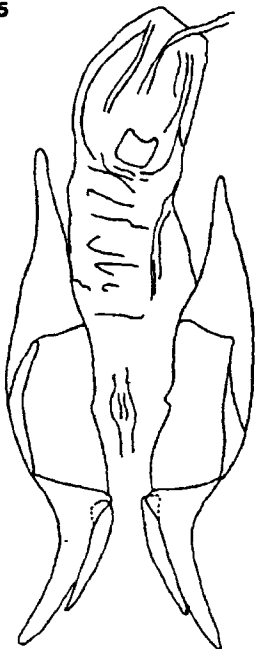
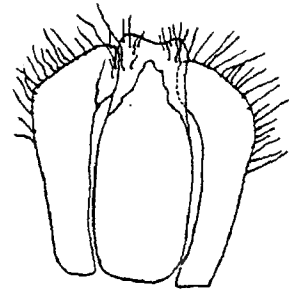
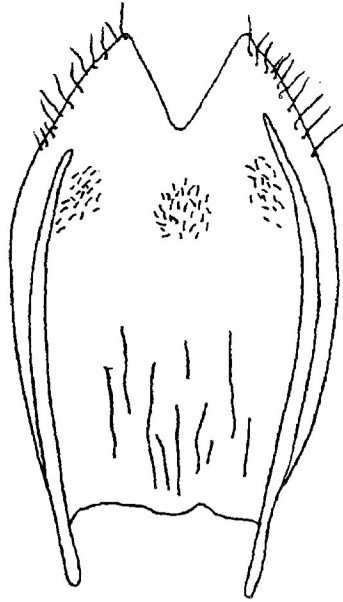
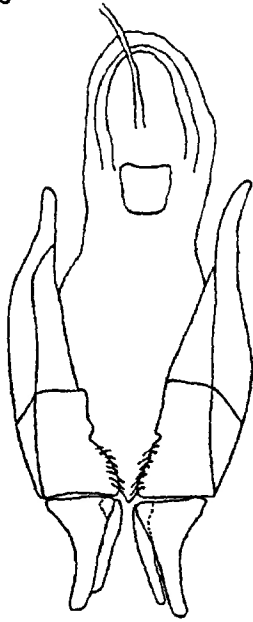

Fig. 66-67. Female genitalia of *C. limbalis* from Osceola, Nebraska (Fig. 66) and Greenwood Lake, New Jersey (Fig. 67).

66



1mm

67

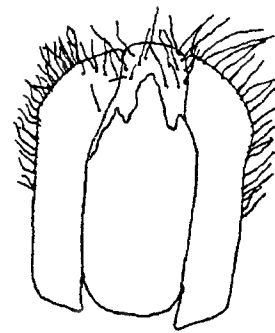
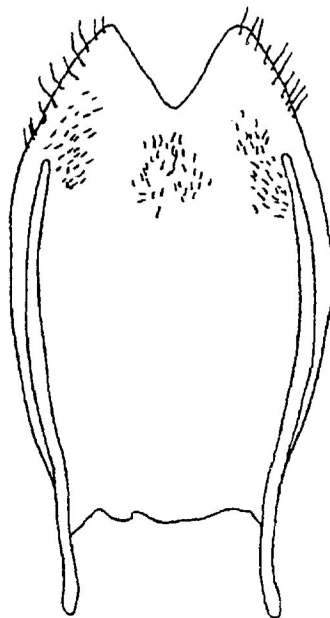
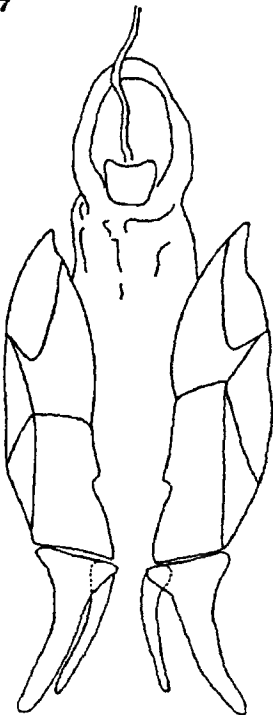

1mm

Fig. 68-69. Female genitalia of *C. limbalis* from Norman Wells, Northwest Territories (Fig. 68) and Thunder Bay, Ontario (Fig. 69).

68

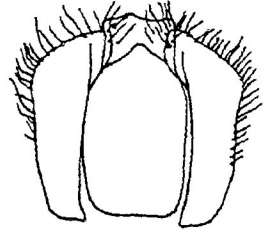
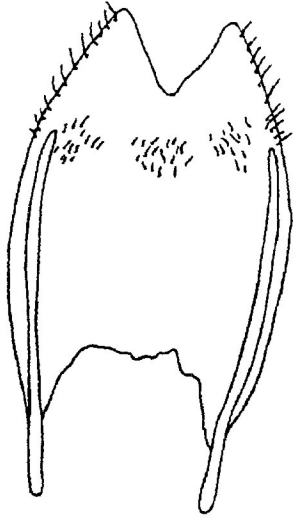
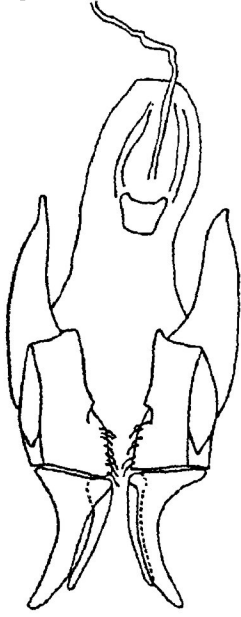

1mm

69

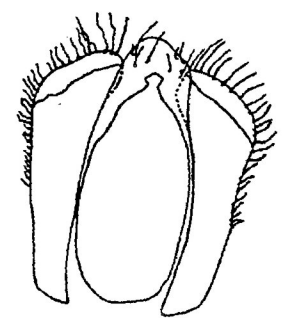
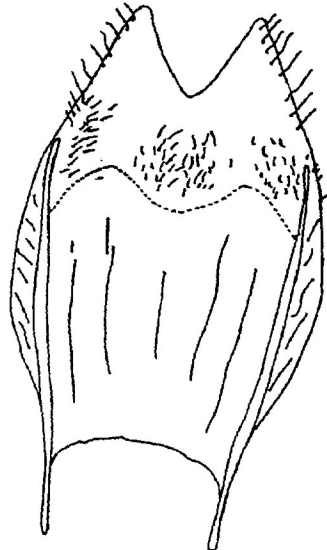
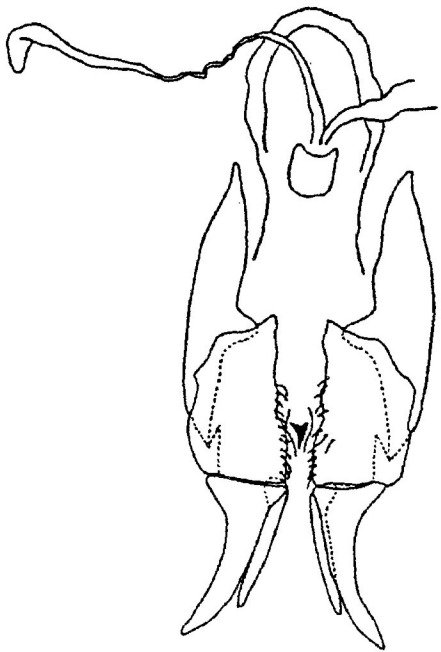

1mm

Fig. 70-71. Female genitalia of *C. denverensis* from Denver, Colorado (Fig. 70) and Dunn County, North Dakota (Fig. 71).

70

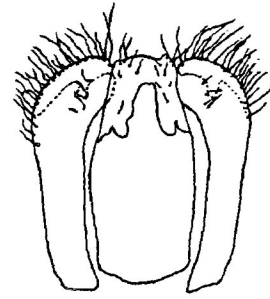
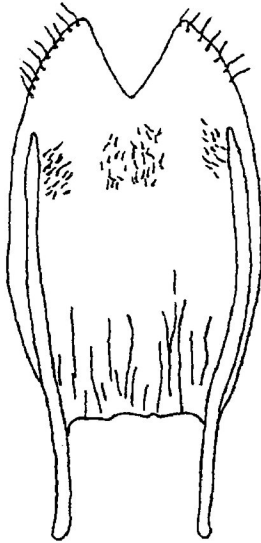
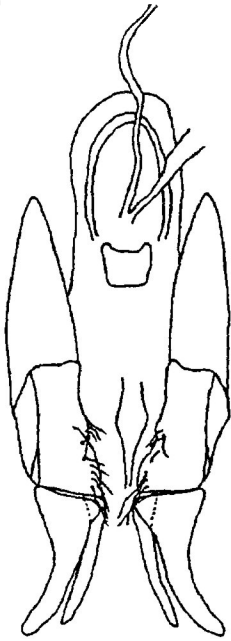

1mm

71

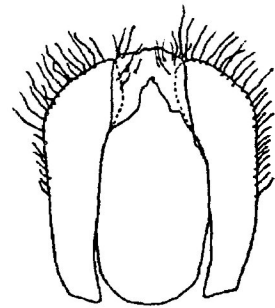
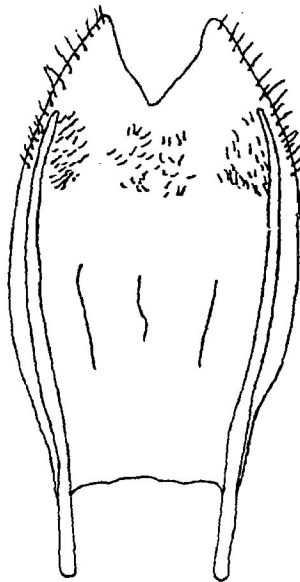
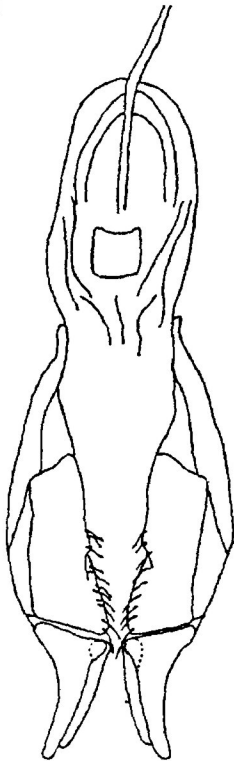

1mm

Fig. 72-73. Female genitalia of *C. denverensis* from Benkelman, Nebraska (Fig. 72) and Lawrence, Kansas (Fig. 73).

72

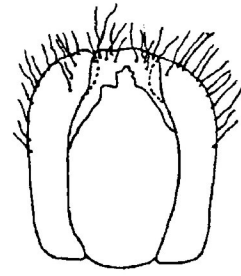
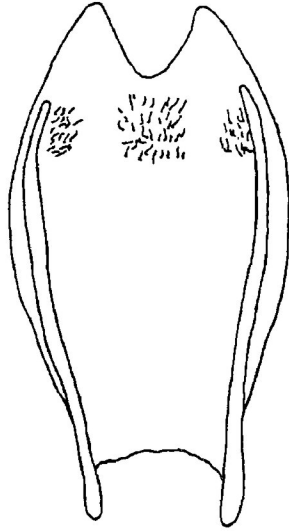

1mm

73

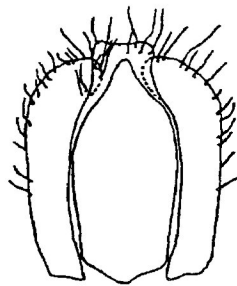
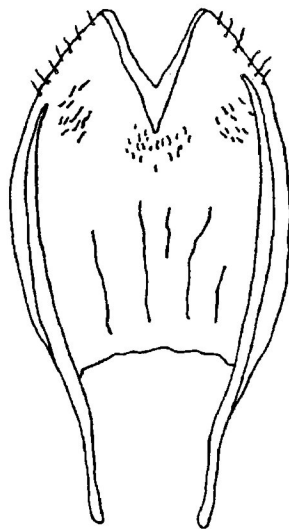
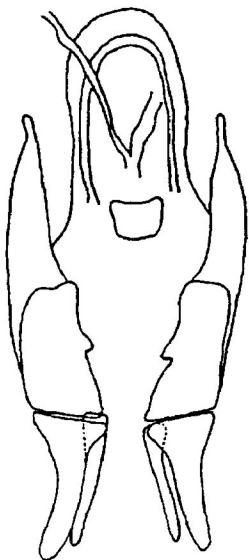

1mm

Soil Associations

Larvae of *C. limbalis* are found principally on moist steep clay banks (Shelford, 1907, 1908, 1911; Hamilton, 1925; Wallis, 1961), but a few occur on wet sandy soil (Criddle, 1907, 1910, 1919).

Shelford (1907) showed that this species, when given the choice between steep and level ground in each of five soil types, i.e., humus, clay and humus, clay, lean sand, and sand and humus, produced larvae almost exclusively in clay. One larva appeared in the clay and humus mixture. Larvae occurred four times more frequently on the steep clay than the level clay. Shelford (1908) showed that mated *C. limbalis* females placed in cages containing sand only and level clay only produced no larvae but that females placed in cages containing rough steep clay, deposited eggs. He also noted that eggs were absent from dry soils, whether steep or level.

Adults of *C. limbalis* are found on moist steep clay banks at the time of emergence (Shelford, 1907, 1908, 1911; Hamilton, 1925; Wallis, 1961). The range of adults is greater in extent than the breeding place or larval habitat (Shelford, 1907, 1911). Adult beetles of *C. limbalis* were found on a steep clay bank, an adjacent sandy beach and in bare places in nearby meadows, pastures, roads and ravines (Shelford, 1911). Criddle (1907, 1910, 1919) stated that *C. limbalis* in its adult state is usually found on semi-moist

roads, on similar moist areas along river banks or on pocket gopher hills in openings among semi-wooded areas. The same soil and habitat preferences are reported for *C. splendida* and *C. denverensis* (Shelford, 1911).

In Canada the greatest number of locality records for *C. limbalis* occurred on Black Chernozemic soil (Table 4). Chernozemic soils have developed within areas of cool Boreal to cold Cryoboreal, subhumid to subarid continental climates and are characteristic of the Canadian prairies and the rangelands of the interior of British Columbia (Clayton et al., 1977). Black Chernozemic soils experience moderate periods of moisture deficits occurring in the growing season and are therefore usually associated with a moderately luxurious growth of mesophytic grasses and forbs, but may also be found in areas of mixed grass, shrub, and tree cover (Clayton et al., 1977).

The second greatest number of locality records for *C. limbalis* occurred on organic soils known as Fibrisols and Mesisols. Although organic soils occur in all provinces and territories of Canada they occur mostly with and adjacent to forested regions. Organic soils occur less frequently in the subhumid to semiarid grasslands and in the tundra regions of the Arctic (Clayton et al., 1977). Organic soils are commonly associated with Gleysolic, Brunisolic, Luvisolic, and Podzolic soils, and to a lesser degree with Regosolic soils and Rockland (Clayton et al., 1977).

Humo-Ferric Podzol was the soil type with the third greatest number of locality records for *C. limbalis*.

Podzolic soils are well to imperfectly drained mineral soils with characteristics and features that developed under the influence of forest or heath vegetation in climatic conditions ranging from cold to mild, and humid to perhumid (Clayton et al., 1977). Podzolic soils in Canada are most commonly found in coarse-textured, frequently stony glacial till or outwash deposits, but are also extensive on glaciofluvial sandy deposits and on some loamy-textured materials (Clayton et al., 1977). Podzols occur on all topographic phases from undulating to mountainous, but more than 70% are found in rolling phases (Clayton et al., 1977). Podzols are frequently found in association with Rockland, Luvisolic, Brunisolic, Gleysolic, and Organic soils.

In the United States, the greatest number of *C. limbalis* locality records occurred on Black Chernozemic soil. The second greatest number occurred on Humo-Ferric Podzol which ranked third in Canada. The third greatest number occurred on Gray Brown Luvisols. Clayton et al. (1977) stated that Gray Brown Luvisols have developed under deciduous or mixed-forest vegetation, mostly under Mesic humid climates, and because of high biological activity, including that of earthworms, are characterized by a rapid incorporation of forest litter. Most Luvisols are found on undulating and rolling topography and lesser areas on steeper

mountain slopes (Clayton et al., 1977). They are most frequently associated with other forest soils, Organic, Brunisolic, and Podzolic, but in many areas of forest-grassland transition, Luvisols are found with Dark Gray Chernozemic and Gleysolic soils (Clayton et al., 1977). The fourth greatest number of *C. limbalis* specimens occurred on Orthic Dystric Brunisol. Clayton et al. (1977) described brunisolic soils as a broad grouping of imperfectly to well drained mineral soils developed under the influence of varying types of forest, alpine, or tundra vegetation. They occur under climatic conditions ranging from Mesic to Arctic in temperatures and from perhumid to semiarid in moisture regimes (Clayton et al., 1977). Orthic Humic Gleysol represents the fifth most common soil type for *C. limbalis* in the United States. Gleysolic soils are poorly drained mineral soils whose profiles reflect the influence of waterlogging for significant periods (Clayton et al., 1977). These soils occur in Subaquic to Peraquic moisture regimes and within all temperature classes from Arctic to Mesic in Canada and from Arctic to Hyperthermic in the United States (Clayton et al., 1977). They have developed under hydrophytic tundra, forest or meadow sedge-grass vegetation (Clayton et al., 1977). The sixth largest number of *C. limbalis* in the United States occurred on organic soils known as Fibrisols and Mesisols. These soils represented the second most important soil types for *C. limbalis* in Canada,

probably because they occur mostly with and adjacent to forested regions.

For *C. splendida* the ranking of soil preference from first to fifth was as follows: Black Chernozemic, Orthic Humic Gleysol, Dark Brown Chernozemic, Gray Brown Luvisol and Brown Chernozemic (Table 5).

For *C. denverensis* the ranking of soil preference from first to fifth was as follows: Dark Brown Chernozemic, Orthic Regosol, Brown Solonetz, Orthic Humic Gleysol and Black Chernozemic (Table 6).

Both *C. splendida* and *C. denverensis* exhibited soil preferences similar to that of *C. limbalis*. *Cicindela splendida* revealed a closer similarity than did *C. denverensis*. All three species showed a preference for Chernozemic soils, with Black Chernozemic being the first choice of *C. limbalis* and *C. splendida* and fifth choice for *C. denverensis*. However, the differences between Dark Brown Chernozemic soil preferred by *C. denverensis* and that of Black Chernozemic preferred by the other two species is probably not of great consequence. Dark Brown Chernozemic soils have dark grayish brown to dark brown dry coloured A horizons with less organic matter than those of Black Chernozemic great groups. They occur within cool Boreal to cold Cryoboreal semiarid climates, characterized by moderately severe moisture deficits within the growing season. These moisture deficits are significantly more

severe in Dark Brown Chernozemic soils than in Black Chernozemic soils. Brown Chernozemic soils which ranked fifth for *C. splendida* are characterized by A horizons with grayish brown to light brownish gray dry colours, which are generally lower in organic matter content than those of the other Chernozemic great groups. They occur within cool Boreal semiarid to subarid climates characterized by severe moisture deficits during the growing season and have developed under a cyclic growth of xerophytic to mesophytic grasses and forbs characteristic of Shortgrass sections of the Mixed Prairie (Clayton et al., 1977).

Cicindela splendida and *C. limbalis* also revealed a preference for Orthic Humic Gleysol and Gray Brown Luvisol. Although *C. denverensis* also had a small preference for Orthic Humic Gleysol, it had a greater preference for Orthic Regosol and Brown Solonetz which are not preferred soils of the other two species. Regosolic soils are well to imperfectly drained mineral soils with profile development too weakly expressed to meet the requirement for classification in any other order (Clayton et al., 1977). They are found widely distributed as subdominant associates or as minor inclusions in many areas of Canada but mainly within the Interior Plains of Manitoba, Saskatchewan, Alberta and Sable Island. They relate to the concept of Entisols (excluding Aquents) in the United States taxonomy (Clayton et al., 1977). Most occur within Boreal and Cryoboreal climatic

regions and are found on coarse, gravelly, or sandy glaciofluvial and eolian deposits, including areas of dune formation, or in sandy to loamy alluvial areas, some of which are strongly calcareous or saline (Clayton et al., 1977). Other Orthic Regosols are also found on loamy, stony, or eroded glacial deposits associated with eroded glacial channels, on upper slope and knoll positions in rolling morainic areas, and on colluvial or talus materials associated with soil wash or soil creep on steep valley or mountain slopes (Clayton et al., 1977).

Solonetzic soils are well to imperfectly drained mineral soils having horizon features of distinctive physical and chemical characteristics believed to result from a combination of processes of salinization by alkaline salts, and desalinization and leaching within the soil (Clayton et al., 1977). Solonetzic soils are mostly developed under a vegetational cover of grasses and forbs, frequently with a significant percentage of alkali-tolerant plants (Clayton et al., 1977). In Canada, Solonetzic soils are found in the Interior Plains Region, particularly in Alberta and Saskatchewan. They occur to a lesser extent in the Peace River area of northeastern British Columbia and in Manitoba (Clayton et al., 1977). They are most frequently associated with Brown, Dark Brown, and Black Chernozemic soils, but are also associated with Dark Gray Chernozemic and Gray Luvisolic soils (Clayton et al., 1977). Under subarid to semiarid

regimes the Brown Solonetz soils have surface A horizons comparable to those of Brown and Dark Brown Chernozemic soils and under subhumid conditions to those of Black and Dark Gray Chernozemic types (Clayton et al., 1977). Where Gray Solonetz soils occur under forest vegetation the A horizons tend to be lower in organic matter, light brownish gray to gray in colour, and similar to those described for Gray Luvisols.

Cicindela splendida and *C. denverensis* are not found in Canada, even though suitable soils are present. Their distribution may result from past geologic events which led to the development of these species. Of the *C. splendida* group, *C. denverensis* has the smallest distribution and occurs on Dark Brown Chernozemic soils, Orthic Regosolic soils, and Brown Solonetzic soils which are primarily found in the Great Plains in the Central United States. Apparently the geographic range of this species is strongly linked to the distribution of these soils. *Cicindela splendida* has a larger distribution but also shows a strong link to Chernozemic and Gleysolic soils which occur in the south central and east central United States. *Cicindela limbalis* has the widest distribution, probably due to its ability to inhabit widespread soil types such as Chernozemic, Podzolic and Luvisolic soils.

Since the distribution of all three species is smaller than the range of their preferred soil types, one

must consider other limiting factors. Shelford (1911) stated that the distribution of *C. limbalis* "represents the margin of the ice sheet, the region of extensive clay deposits which are being eroded rapidly, and the slope of the mountains where erosion is also rapid."

In the Thunder Bay District, *C. limbalis* was principally found on steep exposed clay banks and precipitous clay cliffs of the Kaministiquia River. Other areas consisted of bare or intermittently bare clay patches along highways, roadsides, small rivers and creeks. They were also found on moist clay piles and in clay pits where a source of rainwater was usually present. Most of these areas represent glaciolacustrine deposits of varved or massive clay, silt, and fine sand (Ontario Department of Lands and Forests, Map S265, Thunder Bay Surficial Geology, Scale 1:506,880 (1965) and Mollard, 1979a, 1979b). Thus, the results of this study support the claim by Shelford (1911) that the overall geographic distribution of *C. limbalis* is determined by the same factors as its local distribution, i.e., by its preference for steep moist bare clay banks of rivers or other clay patches near sources of water. The same conclusion can also be drawn for *C. splendida* and *C. denverensis* which show distribution patterns that are probably linked to microgeographic differences in habitats.

Table 4. Relative frequency (%) and absolute frequency (in brackets) of occurrence of locality records of *C. limbalis* on dominant soil types as indicated by soil maps (see text for references of soil maps).

	AB	BC	MB	NB	NF	NT	NS	ON	PQ	SK	CO	CT	IL	IA	KS	ME	MA
Brown Chernozemic										15%(11)							
Dark Brown Chernozemic										29%(22)	5.6%(3)						
Black Chernozemic	86%(210)		88%(116)							17%(13)			30.1%(187)	93.3%(292)	93%(13)		
Dark Gray Chernozemic																	
Brown Solonetz										4%(3)							
Black Solonetz	2.5%(6)																
Black Solod																	
Gray Brown Luvisol								7.5%(20)					68.8%(427)	1.3%(4)			
Gray Luvisol	2.5%(6)	100%(9)	11%(15)					10%(26)		3%(2)	40.7%(22)						
Humo-Ferric Podzol				100%(3)	100%(1)			25.5%(68)	47.5%(48)			100%(7)					100%(152)
Orthic Melanic Brunisol								48.5%(49)									100%(1)
Orthic Eutric Brunisol						52%(15)											
Orthic Dystric Brunisol								7%(18)	1%(1)								
Orthic Regosol																	
Cumulic Regosol						48%(14)											
Cryic Orthic Regosol																	
Orthic Humic Gleysol								2%(6)	3%(3)				1.1%(7)	5.4%(17)			
Orthic Gleysol																	
Cryic Orthic Gleysol																	
Fibrisol & Mesisol	9%(22)							48%(127)		32%(24)							
Cryic Fibrisol																	
Rockland Number	244	9	132			29	20	256	101	75	54		621	313	14	152	

Table 4. (Continued)

	NI	NN	NO	NT	NE	NH	NJ	NN	NY	ND	PA	SD	VT	WI	WY	Total
Brown Chernozemic																11
Dark Brown Chernozemic												24.3%(17)				43
Black Chernozemic		35.2%(124)		100%(8)	16.7%(17)					58.54%(24)		42.85%(30)			6.7%(1)	1035
Dark Gray Chernozemic																0
Brown Solonetz								60%(3)							80%(12)	18
Black Solonetz																6
Black Solod																0
Gray Brown Luvisol	10.5%(2)	36.1%(127)	8.5%(4)						0.9%(1)					32.5%(25)		610
Gray Luvisol		14.2%(50)						40%(2)				32.85%(23)			13.3%(2)	157
Humo-Ferric Podzol	89.5%(17)					100%(14)							100%(349)	67.5%(52)		732
Orthic Melanic Brunisol																49
Orthic Eutric Brunisol																15
Orthic Dystric Brunisol							93.9%(62)		99.1%(106)		76.3%(87)					274
Orthic Regosol		10.5%(37)								26.83%(11)						77
Cumulic Regosol																14
Cryic Orthic Regosol																0
Orthic Humic Gleysol		4.0%(14)	91.5%(43)		83.3%(85)		6.1%(4)			14.63%(6)	23.7%(27)					203
Orthic Gleysol																9
Cryic Orthic Gleysol																0
Fibrisol & Mesisol																173
Cryic Fibrisol																0
Rockland Number	19	352	47		102	14	66		107	41	114	70	349	77	15	3427

Table 5. Relative frequency (%) and absolute frequency (in brackets) of occurrence of locality records of *C. splendida* on dominant soil types as indicated by soil maps (see text for references of soil maps).

	AR	CO	DC	GA	IL	IA	KS	KY	LA	MD	MO
Brown Chernozemic											
Dark Brown Chernozemic		50%(5)					29.5%(99)				
Black Chernozemic					17%(5)		69%(233)		35%(8)		
Dark Gray Chernozemic											
Brown Solonetz		10%(1)									
Black Solonetz											
Black Solod											
Gray Brown Luvisol					83%(24)	100%(5)					
Gray Luvisol		10%(1)									
Humo-Ferric Podzol											
Orthic Melanic Brunisol											
Orthic Eutric Brunisol											
Orthic Dystric Brunisol											
Orthic Regosol		30%(3)									
Cumulic Regosol											
Cryic Orthic Regosol											
Orthic Humic Gleysol	94%(90)		100%(6)	100%(1)			1.5%(5)	100%(16)	65%(15)	100%(1)	100%(24)
Orthic Gleysol	6%(6)										
Cryic Orthic Gleysol											
Fibrisol & Mesisol											
Cryic Fibrisol											
Rockland											
Number	96	10	6		29	5	337	16	23		24

Table 5. (Continued)

	NE	NM	NC	OH	OK	PA	SC	TN	TX	VA	Total
Brown Chernozemic									39%(16)		16
Dark Brown Chernozemic	5%(17)				87%(13)			29%(2)			136
Black Chernozemic	82.5%(278)				6.5%(1)						525
Dark Gray Chernozemic											0
Brown Solonetz		20%(1)									2
Black Solonetz											0
Black Solod											0
Gray Brown Luvisol		80%(4)		50%(1)					49%(20)		54
Gray Luvisol											1
Humo-Ferric Podzol											0
Orthic Melanic Brunisol											0
Orthic Eutric Brunisol											0
Orthic Dystric Brunisol				50%(1)		100%(2)				14%(3)	6
Orthic Regosol											3
Cumulic Regosol											0
Cryic Orthic Regosol											0
Orthic Humic Gleysol	12.5%(42)		100%(101)		6.5%(1)		100%(1)	71%(5)	12%(5)	86%(18)	331
Orthic Gleysol											6
Cryic Orthic Gleysol											0
Fibrisol & Mesisol											0
Cryic Fibrisol											0
Rockland											0
Number	337	5	101		15				41	21	1,080

Table 6. Relative frequency (%) and absolute frequency (in brackets) of occurrence of locality records of *C. denverensis* on dominant soil types as indicated by soil maps (see text for references of soil maps).

	AR	CO	KS	KY	LA	MT	NE	NH	ND	OK	SD	TX	WY	Total
Brown Chernozemic			17%(1)											1
Dark Brown Chernozemic		68%(111)	50%(3)				96%(45)			33.3%(1)	75%(3)	100%(7)		170
Black Chernozemic									75%(3)	33.3%(1)			100%(1)	5
Dark Gray Chernozemic														0
Brown Solonetz		10.5%(17)						100%(2)						19
Black Solonetz														0
Black Solod														0
Gray Brown Luvisol														0
Gray Luvisol		0.5%(1)									25%(1)			2
Humo-Ferric Podzol														0
Orthic Melanic Brunisol														0
Orthic Eutric Brunisol														0
Orthic Dystric Brunisol														0
Orthic Regosol		21%(34)	33%(2)			100%(6)			25%(1)					43
Cumulic Regosol														0
Cryic Orthic Regosol														0
Orthic Humic Gleysol	67%(2)			100%(1)	100%(1)		4%(2)			33.4%(1)				7
Orthic Gleysol	33%(1)													1
Cryic Orthic Gleysol														0
Fibrisol & Mesisol														0
Cryic Fibrisol														0
Rockland														0
Number		163	6			6	47	2	4	3	4		1	248

Numerical Analyses of Morphometric Data

The examination of sexual dimorphism using the one-way analysis of variance (ONEWAY) procedure indicated that females of all three species showed significantly larger measurements in head width, labrum length and width, pronotum width and elytra length and width. In addition females of *C. limbalis* were significantly larger in pronotum length, femur length and tibia length whereas females of *C. splendida* were significantly larger in pronotum length and femur length and females of *C. denverensis* showed no significant difference for these three measurements. A Kruskal-Wallis One-Way Analysis of Variance revealed the same results with the addition that tibia length was significantly larger in females of *C. splendida* and that pronotum length was significantly larger in females of *C. denverensis*. Because females in each species were significantly larger in overall size than males, data for each sex were treated separately in subsequent analyses.

Examination of intraspecific variation, using a one-way analysis of variance (ONEWAY) procedure, within each species indicated that no particular population differed sufficiently from others to warrant subspecies recognition. Although some variables indicated significant differences among populations, using the accepted level of significance at 0.05, there was no definite pattern to these differences, nor were they taxonomically significant.

Within each species, specimens tended to be larger in the northern and eastern populations. Elytral maculations, within each species, tended to be greater in specimens from northern and central populations. These trends were especially prominent in *C. splendida* and *C. denverensis* and to a lesser extent, in *C. limbalis*. The number of characters which revealed significant differences was greater in males than females for the species *C. splendida* and *C. denverensis* but was the same in males and females of *C. limbalis*. Trends within *C. limbalis* were not obvious as this species revealed a greater degree of variability in character means than did the other species. Variation in elytral maculation and colour was also the greatest in *C. limbalis*. Although maculations in *C. limbalis* tended to be greater in northern populations, the most maculated forms (from Sedalia, Colorado) and least maculated forms (from Louisiana, Missouri) both occurred in the southern populations. The colour differences were also greater in *C. limbalis*, with brick red or cupreous forms in both northern and southern forms; cupreous red with a purple hue in southern and eastern forms; and dull green or muddy brown green in northern forms.

The results of factor and discriminant analyses of males using all variables and all factors are given in Tables 7 to 14. Table 7 gives the percentage of variance explained by factors used in the factor analysis. Table 8 indicates

the correlated variables which make up the factors. The factors can be explained as follows: factor 1=hw, fl, el, pl, lw, pw, ew, tl; factor 2=percent maculation, hl, mb, al, (ew/el); factor 3=osl, osr, ec; factor 4=(pl/pw), (pw/hw), (fl/tl); factor 5=(ll/lw), ll; factor 6=ssl, sss, lsl; factor 7=ls2, ls3; and factor 8=ls4. Factor 1 which accounted for 27.7% of the variance was composed entirely of body measurements (continuous variables) while factor 2 which accounted for 14.5% of the variance was composed of elytral patterns (discontinuous variables) and the elytral ratio (continuous variables). Factor 3 accounted for 9.8% of the variance and consisted of non-sensory setae number and elytral colour. The remaining factors were composed of a few continuous variables and several discontinuous variables. These remaining factors taken separately did not account for significant variance in the analysis.

From the discriminant analysis, Table 9 indicated that in function 1, which accounted for 67.09% of the variance, factor 3 and factor 2 were of greatest importance and that in function 2, which accounted for 32.91% of the variance, factor 2 and factor 3 were of greatest importance. The remaining factors were less important and 2 factors, i.e. 7 and 8 were removed by the discriminant analysis procedure. Table 10 indicated that 86.02% of the grouped specimens were correctly classified to their own group.

The results of factor and discriminant analyses of

females using all variables are given in Tables 15 to 22. Table 15 gives the percentage of variance explained by factors used in the factor analysis. Table 16 indicates the correlated variables which make up the factors. All factors were similar to those of the males. The factors can be explained as follows: factor 1=hw, el, fl, lw, pl, pw, ew, tl; factor 2=percent maculation, hl, mb, al; factor 3=osl, osr, ec; factor 4=(ll/lw), ll, (ew/el); factor 5=(pl/pw), (pw/hw); factor 6=ssl, ssr; factor 7=ls3, ls2; and factor 8=(fl/tl). Factor 1 which accounted for 29.0% of the variance was composed entirely of body measurements (continuous variables) while factor 2 which accounted for 15.8% of the variance was composed of elytral patterns. Factor 3 accounted for 9.1% of the variance and consisted of non-sensory setae number and elytral colour. The remaining factors were composed of a few continuous variables and several discontinuous variables.

From the discriminant analysis, Table 17 indicated that in function 1, which accounted for 64.82% of the variance, factors 3, 1 and 2 were of greatest importance and that in function 2, which accounted for 35.18% of the variance, factors 2 and 3 were of greatest importance. Table 18 indicated that 86.17% of the grouped specimens were correctly classified to their own group.

Apparently, elytral patterns and colour were the best discriminating features for both males and females,

whereas factor 1 which consisted mainly of body measurements was not as important. This suggested that morphometric data alone could not separate these species. Thus, the discriminant analysis was repeated using factors 2 and 3 only and then again excluding factors 2 and 3, in an attempt to show that elytral pattern, percentage maculation, and elytral colour were the only way of separating these species.

The results of the discriminant analysis using selected factors are given in Tables 11 to 14 for males and Tables 19 to 22 for females. When factors 2 and 3 only were employed in the analysis, 84.19% of the males were correctly classified and 83.28% of the females were correctly classified. When factors 2 and 3 were excluded, 45.90% of the males were correctly classified and 50.48% of the females were correctly classified. Thus this indicated that for both males and females elytral pattern, percentage maculation, elytral colour and non-sensory setae number, collectively, are the only way of separating these species, whereas body measurements, body ratios, sensory setae and labral setae, collectively, fail to separate these species.

In both sexes, the classification results of the discriminant analysis indicated that within the *C. splendida* group, *C. splendida* and *C. limbalis* were more similar to each other than to *C. denverensis*. Furthermore, in both sexes, an all-groups scatterplot indicated that group centroids for *C. splendida* and *C. limbalis* were closer to each other than to

C. denverensis. Although, in both sexes, the group centroid of *C. denverensis* was closer to *C. splendida* than to *C. limbalis*, more overlap occurred between *C. splendida* and *C. limbalis* than occurred between these species and *C. denverensis*.

Table 7. Percentage of variance explained by factors used in the factor analysis of males.

Factor	Eigenvalue	Pct. of Var.	Cum. Pct.
1	7.46897	27.7	27.7
2	3.92297	14.5	42.2
3	2.65900	9.8	52.0
4	1.99354	7.4	59.4
5	1.47914	5.5	64.9
6	1.24489	4.6	69.5
7	1.18074	4.4	73.9
8	1.02215	3.8	77.7

Factors with eigenvalues less than 1 where removed by the factor analysis procedure.

Table 8. Rotated factor matrix for males.

	Factor1	Factor2	Factor3	Factor4	Factor5	Factor6	Factor7	Factor8
hw	.93469	-.08955	-.09450	-.03695	.04435	-.03886	.00179	-.01883
fl	.92363	.11383	-.07127	.05820	.03905	.01311	.01772	.04367
el	.91817	.07913	-.07680	.02029	-.02747	.11913	-.01756	.08232
pl	.91660	-.10582	.02934	-.09389	.09150	.03776	.01356	-.03604
lw	.90927	.12308	.02387	.07147	.06709	.03276	.08800	-.02079
pw	.89593	-.02270	-.12513	.36602	.10536	.00249	.01367	.00561
ew	.88708	-.17814	.09477	.19345	.15815	-.04448	-.03327	-.08267
tl	.86656	.17834	-.23712	-.13420	-.02016	.09145	.01034	.08411
% macul.	.02152	.95166	-.03265	.05130	.00568	.06402	.03228	-.04794
hl	.02878	.91495	.02026	.08150	.02364	.07430	.01696	-.03844
mb	.05132	.90124	-.12944	.11688	.05636	.02256	-.00579	-.04355
al	-.02708	.86529	.09936	-.05302	-.00776	.12448	.02090	.10503
(ew/el)	.00209	-.40935	.28744	.27874	.29989	-.25232	-.02112	-.25982
osl	-.11148	-.00603	.87345	-.15066	-.14681	.16959	.10604	.00748
osr	-.14554	.00245	.86223	-.13472	-.13346	.23255	.08527	.01773
ec	-.00699	.00892	.57188	-.06953	.12947	-.28059	-.11768	.01882
(pl/pw)	-.01756	-.14227	.27009	-.80646	-.02419	.06515	.00370	-.06976
(pw/hw)	.23548	.10312	-.09065	.78848	.13873	.07003	.01891	.04690
(fl/tl)	-.07581	-.16026	.36515	.37952	.11769	-.16071	.01070	-.09522
(ll/lw)	.05766	.01625	-.06494	.11666	.96002	-.03431	-.00309	.06971
ll	.57157	.08674	-.04447	.13065	.77707	-.00944	.04794	.04519
ssl	.07870	.12938	.09863	-.04225	-.04127	.81482	.08920	.06589
ssr	.05148	.17333	.02718	-.17045	-.10233	.79533	.01621	-.02723
ls1	.00226	-.01361	-.03605	.11115	.07118	.30491	-.14161	-.07315
ls2	.05092	-.01129	-.04159	-.02172	-.02087	-.04162	.85755	.11027
ls3	.00943	.06118	.08998	.04564	.04596	.00547	.85159	-.11978
ls4	.02713	-.01929	.01513	.07077	.08561	-.06067	-.00266	.94714

Table 9. Standardized canonical discriminant function coefficients for males using all factors.

	Function 1	Function 2
Factor 1	0.30188	-0.29858
Factor 2	0.65798	0.76919
Factor 3	-0.90706	0.46528
Factor 4	0.30195	0.14195
Factor 5	-0.20179	0.29587
Factor 6	0.13973	-0.27066

Function 1 accounted for 67.09% of the variance and Function 2 accounted for 32.91% of the variance.

Table 10. Classification results of male discriminant analysis using all factors.

Actual Group	No. of Specimens	Predicted Group Membership		
		1	2	3
Group 1 <i>splendida</i>	80	63 78.8%	15 18.8%	2 2.5%
Group 2 <i>limbalis</i>	204	20 9.8%	181 88.7%	3 1.5%
Group 3 <i>denverensis</i>	45	1 2.2%	5 11.1%	39 86.7%

Percent of grouped specimens correctly classified: 86.02%.

Table 11. Standardized canonical discriminant function coefficients for males using factors 2 and 3 only.

	Function 1	Function 2
Factor 2	-0.77779	0.65585
Factor 3	0.78784	0.64373

Function 1 accounted for 69.24% of the variance and Function 2 accounted for 30.76% of the variance.

Table 12. Classification results of male discriminant analysis using factors 2 and 3 only.

Actual Group	No. of Specimens	Predicted Group Membership		
		1	2	3
Group 1 <i>splendida</i>	80	61 76.3%	14 17.5%	5 6.3%
Group 2 <i>limbalis</i>	204	14 6.9%	180 88.2%	10 4.9%
Group 3 <i>denverensis</i>	45	4 8.9%	5 11.1%	36 80.0%

Percent of grouped specimens correctly classified: 84.19%.

Table 13. Standardized canonical discriminant function coefficients for males excluding factors 2 and 3.

	Function 1	Function 2
Factor 1	0.69165	0.07508
Factor 4	0.14794	0.95950
Factor 5	-0.58119	0.14307
Factor 6	0.48364	-0.23112

Function 1 accounted for 79.89% of the variance and Function 2 accounted for 20.11% of the variance.

Table 14. Classification results of male discriminant analysis excluding factors 2 and 3.

Actual Group	No. of Specimens	Predicted Group Membership		
		1	2	3
Group 1 <i>splendida</i>	80	48 60.0%	20 25.0%	12 15.0%
Group 2 <i>limbalis</i>	204	71 34.8%	72 35.3%	61 29.9%
Group 3 <i>denverensis</i>	45	10 22.2%	4 8.9%	31 68.9%

Percent of grouped specimens correctly classified: 45.90%.

Table 15. Percentage of variance explained by factors used in the factor analysis of females.

Factor	Eigenvalue	Pct. of Var.	Cum. Pct.
1	7.25447	29.0	29.0
2	3.93800	15.8	44.8
3	2.27627	9.1	53.9
4	2.04531	8.2	62.1
5	1.47771	5.9	68.0
6	1.21420	4.9	72.8
7	1.14403	4.6	77.4
8	1.03433	4.1	81.5

Factors with eigenvalues less than 1 were removed by the factor analysis procedure.

Table 16. Rotated factor matrix for females.

	Factor1	Factor2	Factor3	Factor4	Factor5	Factor6	Factor7	Factor8
hw	.93607	-.03556	-.06426	.01118	-.02351	.01575	-.00035	.03629
el	.93284	-.03140	.03369	-.08687	.07233	-.02602	-.05863	-.11971
fl	.91585	.08236	-.12261	-.03072	.10297	-.07052	.01793	.06293
lw	.90407	.19265	-.04800	.04964	.06081	.04755	.01550	.01801
pl	.89900	-.05776	.04952	.10136	-.21475	-.06216	.02842	.08207
pw	.88955	-.02846	-.07457	.12056	.36215	-.05582	.04678	.09176
ew	.87953	-.06850	-.06331	.22242	.05083	.02453	.13473	.09960
tl	.84770	.10002	-.13564	-.02564	.03866	-.03605	.01789	-.41259
% macul.	.03253	.95507	.01442	-.06292	.05575	.11333	.03245	-.00553
hl	.01954	.92306	.06047	-.08152	.01502	.12095	.05809	-.04320
mb	.09388	.91813	-.02267	-.03761	.07441	.06808	.05940	-.00793
al	-.04860	.82311	.15233	.00141	-.08591	.07147	.02198	-.03344
osl	-.15407	.10282	.87867	-.04721	-.10692	.20978	-.06955	-.03851
osr	-.14319	.11346	.87684	-.03860	-.11314	.17816	-.07565	-.03656
ec	.04003	-.00508	.60173	.14928	-.05254	-.13731	.22819	.11760
(ll/lw)	-.06251	-.13698	.10768	.89930	.13003	-.11759	-.11537	-.05590
ll	.49526	.00396	.05296	.79771	.14922	-.06760	-.08721	-.03994
(ew/el)	-.00105	-.06480	-.16689	.53297	-.03498	.07959	.33346	.37097
(pl/pw)	.02772	-.04745	.19689	-.02399	-.89766	-.00987	-.01971	-.01350
(pw/hw)	.29189	.00239	-.05151	.21916	.75125	-.13953	.08745	.12577
ssl	-.10226	.16962	.06246	-.02330	-.00938	.83786	.05397	.03505
ssr	.04141	.14488	.13169	-.08299	-.08503	.83171	.00143	-.08381
ls3	.08537	.07646	-.03946	.01973	-.05407	.02301	.79135	-.01332
ls2	-.01108	.06190	.10519	-.07737	.14505	.02243	.75480	.02437
(fl/tl)	.02046	-.04935	.05052	.00122	.11397	-.05960	-.00228	.93172

Table 17. Standardized canonical discriminant function coefficients for females using all factors.

	Function 1	Function 2
Factor 1	-0.46664	-0.17728
Factor 2	-0.42404	0.89163
Factor 3	0.93327	0.37735
Factor 4	0.28482	-0.02311
Factor 5	-0.37591	0.29393
Factor 7	0.06785	0.20893

Function 1 accounted for 64.82% of the variance and Function 2 accounted for 35.18% of the variance.

Table 18. Classification results of female discriminant analysis using all factors.

Actual Group	No. of Specimens	Predicted Group Membership		
		1	2	3
Group 1 <i>splendida</i>	76	61 80.3%	13 17.1%	2 2.6%
Group 2 <i>limbalis</i>	193	16 8.3%	172 89.1%	5 2.6%
Group 3 <i>denverensis</i>	42	0 0.0%	7 16.7%	35 83.3%

Percent of grouped specimens correctly classified: 86.17%.

Table 19. Standardized canonical discriminant function coefficients for females using factors 2 and 3 only.

	Function 1	Function 2
Factor 2	-0.36116	0.93352
Factor 3	0.94837	0.32014

Function 1 accounted for 58.04% of the variance and Function 2 accounted for 41.96% of the variance.

Table 20. Classification results of female discriminant analysis using factors 2 and 3 only.

Actual Group	No. of Specimens	Predicted Group Membership		
		1	2	3
Group 1 <i>splendida</i>	76	59 77.6%	14 18.4%	3 3.9%
Group 2 <i>limbalis</i>	193	15 7.8%	162 83.9%	16 8.3%
Group 3 <i>denverensis</i>	42	1 2.4%	3 7.1%	38 90.5%

Percent of grouped specimens correctly classified: 83.28%.

Table 21. Standardized canonical discriminant function coefficients for females excluding factors 2 and 3.

	Function 1	Function 2
Factor 1	0.69155	-0.65174
Factor 4	-0.44308	0.01860
Factor 5	0.62690	0.73621

Function 1 accounted for 80.82% of the variance and Function 2 accounted for 19.18% of the variance.

Table 22. Classification results of female discriminant analysis excluding factors 2 and 3.

Actual Group	No. of Specimens	Predicted Group Membership		
		1	2	3
Group 1 <i>splendida</i>	76	36 47.4%	26 34.2%	14 18.4%
Group 2 <i>limbalis</i>	193	56 29.0%	93 48.2%	44 22.8%
Group 3 <i>denverensis</i>	42	10 23.8%	4 9.5%	28 66.7%

Percent of grouped specimens correctly classified: 50.48%.

Elytral Colour and Maculations

Immature adults of *C. limbalis* undergo colour changes from blue to green, green to reddish green, red and finally a dingy brown or near black in older mature specimens (Shelford, 1917). He noted that if these specimens were killed, pinned, and dried so as to show a series from the beginning of colour development to completion, that the colour changes were in the opposite direction as compared to the ontogeny changes. That is, on drying of fresh immature specimens, the earliest stage was dull black, the second purple, the third blue, and individuals in the green stage turned fiery red. The causes of these physical changes is unknown. Through experimental modification of colour, Shelford (1917) noted that *C. limbalis* individuals, when subjected to high temperatures, exhibited a deeper, more brilliant red colour and reflections more strikingly blue than in the normal specimen at this stage. In moist conditions dull colours were obtained. Individuals subjected to high temperatures in moist conditions were more generally dull green, although an iced specimen showed similarities to the warm moist individuals. Elytral maculations were increased in extent by cold conditions and reduced by warm conditions. The experimental modifications by Shelford (1917) nearly duplicated certain geographic races that occurred in localities where conditions were similar to the experimental conditions. Shelford (1917) stated that

although geographic races and geographic distribution was not correlated with any observed climatic or meteorological conditions except possibly rainfall, and even this correlation was not complete, the lack of correlation was believed to be due to a lack of records of soil conditions.

Although environmental conditions, especially edaphic factors probably contributed to variation in elytral colour and maculation in the *C. splendida* group, there must still be a strong genetic control over these phenotypic characters. The three species involved, although highly variable, are still distinguishable from each other based on these features, even though these features are considered of limited utility as taxonomic characters. The co-existence of all three species, distinguishable by their colour and maculation, in regions where they were sympatric, suggests that the genetic control of elytral colour and maculation is greater than environmental influences. Also, the presence of only a few colour hybrids in regions of sympatry further supports the argument for three species, although in many other ways, they are very similar and probably arose from a common ancestor.

Classification

1. *Cicindela splendida* Hentz 1830-254
 - discus* Klug 1834-23
 - ludoviciana* Leng 1902-132
 - cycanocephala* Varas-Arangua 1928-239 *New Synonymy*
 - cycanocephalata* Eckhoff 1939-211 *New Synonymy*
 - cycanocephalanota* Eckhoff 1970-32 *New Synonymy*

Recognition: The head and pronotum are entirely bright metallic green or blue as occurs in *C. denverensis*. The colour of the elytra is bright brick red or cupreous as in *C. limbalis*. The elytral maculation varies from a small apical dot and a small transverse "accent mark" representing the middle band, to two humeral dots, a full middle band and a near complete apical lunule.

2. *Cicindela limbalis* Klug 1834-29
 - amoena* LeConte 1848-177
 - spretta* LeConte 1848-177
 - splendida* LeConte 1856-36
 - transversa* Leng 1902-131 *New Synonymy*
 - awemeana* Casey 1913-23
 - eldorensis* Casey 1913-23
 - militaris* Varas-Arangua 1928-242

Recognition: The dorsal surfaces are bright brick red or cupreous (in both northern and southern forms) or cupreous red with a purple hue (in some southern and eastern forms) or dull green or muddy brown green (in northern forms) as in *C. purpurea*. The elytral maculation varies from a small apical dot and a small transverse "accent mark" representing the middle band, to a complete humeral lunule, middle band and apical lunule, all joined by a marginal band. Specimens of *C. limbalis* are distinguished from those of the greenish forms of *C. purpurea* by a longer and distinctly bent complete middle band that reaches the margin, the basal portion of which is longer and more transverse than in *C. purpurea*, and with a longer more oblique downward arm extending toward the elytral suture.

3. *Cicindela denverensis* Casey 1897-297
 - graminea* Casey 1913-21
 - conquisita* Casey 1914b-357
 - oreada* Casey 1914b-358
 - plattensis* Smyth 1933-202

Recognition: The dorsal surfaces are bright metallic green or blue. The elytral maculation varies from a small apical dot and a small transverse "accent mark" representing the middle band, to a complete humeral lunule, middle band and apical lunule.

Key to the Species of the *C. splendida* Group

- 1a. Head, pronotum, and elytra bright metallic green or blue
..... *C. denverensis*
- 1b. Head and pronotum differently coloured from elytra or
body entirely brick red or cupreous 2
- 2a. Head and pronotum bright metallic green or blue, elytra
brick red or cupreous *C. splendida*
- 2b. Body entirely brick red or cupreous *C. limbalis*

See also key by Willis (1968).

Although Johnson (1983) and Rumpff (1984) have stated that *C. splendida*, *C. limbalis* and *C. denverensis* are the same and should be grouped under the oldest name available, *C. splendida*; I suggest that each of the three retain its specific rank. Although my studies of the genitalia of the group reveal more similarities than differences among the main forms, mating behaviour in these beetles strongly suggests a post-copulatory isolating mechanism. Evidence from the morphometric analyses indicates that intraspecific variation within each species is not taxonomically significant. Interspecific variation in such variables as elytral pattern, percentage maculation and elytral colour is taxonomically significant, whereas body measurements fail to separate these species.

A list of synonyms, based on original descriptions

and personal examination of specimens, is provided for the species recognized. The taxon, *C. limbalis transversa*, is considered conspecific with *C. limbalis*. The reasons for this decision are: (1) a wide range within the *C. limbalis* distribution; (2) the genitalic similarity to *C. limbalis*; and (3) the arbitrariness of naming the *transversa* form based on one characteristic, i.e., the highly variable middle band. Similarly, the taxon, *C. splendida cyanocephalata*, is considered conspecific with *C. splendida*. The reasons for this decision are: (1) the small number of specimens which occur over much of the *C. splendida* range; (2) the lack of genitalic uniqueness; and (3) the arbitrariness of its separation based on a more prominent middle band and occasional humeral and subhumeral dots.

Colour is accepted by most taxonomists as a taxonomic character of questionable value among species of *Cicindela*. However, elytral pattern, percentage maculation and elytral colour, taken collectively, are useful for distinguishing among adults of these species. Species do not exhibit introgressive hybridization in areas where sympatric and parapatric populations occur. I have seen beetles of *C. limbalis* and *C. denverensis* with mixed colours and maculations only in a few populations occurring in Slope County, North. The fact that these forms occur in the same localities, on the same or similar clay substrate, and yet maintain their distinguishing characteristics, with only a

few hybrids evident, suggests a genetic basis for these characters and therefore three very closely related species.

The section which follows includes for each named form a list of taxonomic literature arranged by author, year and page number.

1. The species *Cicindela splendida* Hentz

Cicindela splendida Hentz 1830, p. 254 (type locality-North Carolina). LeConte 1848, p. 176 and 1856, p. 36. Schaupp 1883, p. 90. Horn 1892, p. 27. Wickham 1894, p. 151; 1899, p. 216 and 1911, p. 5. Casey 1897, p. 296 and 1913, p. 8 and 22. Knaus 1900, p. 112 and 1901, p. 112. Fox 1902, p. 198. Leng 1902a, p. 135; 1902b, p. 133 and 1920, p. 40. Sherman 1904, p. 29 and 1908, p. 361. Smyth 1907, p. 180; 1933, p. 197-204 and 1935, p. 16. Horn 1908, p. 373. Harris 1911, p. 7. Harris and Leng 1916, p. 4. Shelford 1917, p. 448. Fackler 1918, p. 37. Frost 1920, p. 229. Dawson and Horn 1928, p. 8. Varas-Arangua 1928, p. 237. Nicolay and Weiss 1932, p. 350. Nicolay 1934, p. 129. Cartwright 1935, p. 70. Meserve 1936, p. 271. Blackwelder 1939, p. 7. Eckhoff 1939, p. 210. Drew and Van Cleave 1961, p. 115. Willis 1968, p. 315; 1970, p. 6 and 1972, p. 10 and 13. Huber 1969a, p. 23. Lawton 1970, p. 2 and 1971, p. 61. Gaumer and Murray 1971, p. 9. Mather 1971, p. 22. Ward 1971, p. 69. Graves and Pearson 1973, p. 171. Larochelle 1974a, p. 32. Freitag 1974, p. 564. Rumpff 1980, 32 pp.; 1981, 10 pp.; 1983, p. 1

and 1984, 9 pp. Schultz 1982, p. 42. Boyd and Associates 1982, p. 8. Johnson 1983, 14 pp. Wilson and Brower 1983, p. 21. Hilchie 1985, p. 329.

Cicindela discus Klug 1834, p. 23. Horn 1908, p. 373. Harris 1911, p. 7. Harris and Leng 1916, p. 4. Leng 1920, p. 40. Meserve 1936, p. 271. Blackwelder 1939, p. 7. Drew and Van Cleave 1961, p. 116. Huber 1969a, p. 20. Rumpff 1980, 32 pp. Boyd and Associates 1982, p. 8.

Cicindela ludoviciana Leng 1902a, p. 132 (type locality-Vowell's Mill, Natchitoches parish, northwestern part of Louisiana). Leng 1902b, p. 133 and 1920, p. 40. Smyth 1907, p. 184; 1933, p. 198 and 1935, p. 16. Horn 1908, p. 373. Harris 1911, p. 8. Casey 1913, p. 8. Harris and Leng 1916, p. 5. Varas-Arangua 1928, p. 240. Nicolay and Weiss 1932, p. 351. Blackwelder 1939, p. 7. Willis 1968, p. 316. Huber 1969a, p. 23. Gaumer and Murray 1971, p. 10. Lawton 1971, p. 61. Ward 1971, p. 69. Graves and Pearson 1973, p. 171. Freitag 1974, p. 564. Laroche 1978, p. 35. Rumpff 1980, 32 pp. and 1983, p. 1. Boyd and Associates 1982, p. 8. Johnson 1983, 14 pp.

Cicindela cyanocephala Varas-Arangua 1928, p. 239 (type locality-N. W. Kansas, Nebraska). Nicolay and Weiss 1932, p. 351. Leng and Mutchler 1933, p. 9. Smyth 1933, p. 197-204

and 1935, p. 16. Nicolay 1934, p. 130. Horn 1938, p. 48. Blackwelder 1939, p. 7. Eckhoff 1939, p. 211. Rivalier 1954, p. 253. Huber 1969a, p. 22 and 1969b, p. 20. Rumpff 1980, 32 pp. Boyd and Associates 1982, p. 8.

Cicindela cyanocephalata Eckhoff 1939, p. 211 (type locality-Clay and loam hills near Maquoketa Park in Jackson County, Iowa). Huber 1969a, p. 20 and 1969b, p. 20. Cutler 1969b, p. 14. Steyskal 1971, p. 34. Lawton 1972, p. 36. Johnson 1979, p. 26 and 1983, 14 pp. Rumpff 1981, 10 pp. and 1983, p. 1. Boyd and Associates 1982, p. 8.

Cicindela cyanocephalanota Eckhoff 1970, p. 32. Willis 1970, p. 6. Steyskal 1971, p. 34. Boyd and Associates 1982, p. 8.

2. The species *Cicindela limbalis* Klug

Cicindela limbalis Klug 1834, p. 29 (type locality-North America). LeConte 1848, p. 177 and 1856, p. 37. Schaupp 1883, p. 90. Wickham 1894, p. 150; 1899, p. 216 and 1911, p. 5. Casey 1897, p. 296 and 1913, p. 8 and 22. Leng 1902a, p. 131; 1912, p. 7, 12 and 13 and 1920, p. 40. Davis 1903, p. 271. Skinner 1904, p. 346. Criddle 1907, p. 110 and 1910, p. 13. Shelford 1907, p. 9; 1908, p. 160; 1913a, p. 125; 1913b, p. 222 and 1917, p. 405. Smyth 1907, p. 180; 1933, p. 197-204 and 1935, p. 15. Horn 1908, p. 373 and 1938, p. 48. Blatchley 1910, p. 33. Harris 1911, p. 6. Greene 1914, p.

237. Harris and Leng 1916, p. 5. Fackler 1918, p. 38.
Frost 1920, p. 229 and 230. Hamilton 1925, p. 3 and 25.
Dawson and Horn 1928, p. 8. Varas-Arangua 1928, p. 241.
Nicolay and Weiss 1932, p. 347. Nicolay 1934, p. 129.
Meserve 1936, p. 271. Blackwelder 1939, p. 7. Eckhoff 1939,
p. 212. LaRivers 1946, p. 135. Vaurie 1950, p. 148.
Rivalier 1954, p. 253. Lindroth 1955, p. 16. Wallis 1961,
p. 15 and 42. Graves 1963, p. 501; 1965, p. 66 and 1969, p.
11. Willis 1968, p. 316 and 1972, p. 13. Gaumer 1969, p. 5.
Huber 1969a, p. 20. Cutler 1969a, p. 5 and 1969b, p. 14.
Ferris 1969, p. 11. Hooper 1969, p. 2. Freitag and Tropea
1969, p. 15 and 23. Wilson 1970b, p. 9 and 1978, p. 13 and
14. Gaumer and Murray 1971, p. 9. Lawton 1971, p. 61 and
68; 1972, p. 35 and 1974, p. 71. Willis and Stamatov 1971,
p. 46. Laroche 1972a, p. 8; 1972b, p. 55; 1974a, p. 27;
1974b, p. 87; 1975, p. 75; 1976, p. 77; 1977, p. 13; 1979, p.
14 and 1980, p. 36. Freitag 1974, p. 564. Boyd 1978, p.
211. Dunn 1978, p. 74 and 1981, p. 4. Ward and Bowling
1980, p. 31. Rumpff 1980, 32 pp; 1981, 10 pp. and 1984, 9 pp.
Larson 1981, p. 52. Morgan and Freitag 1982, p. 105. Nagano
et al. 1982, p. 342. Beatty and Knisley 1982, p. 2. Boyd
and Associates 1982, p. 8. Johnson 1983, 14 pp. Wilson and
Brower 1983, p. 3 and 10. Hilchie 1985, p. 329.

Cicindela limbalis var. LeConte 1856, p. 36. Schaupp 1883,
p. 90. Wickham 1894, p. 151. Casey 1897, p. 296. Haimbach

1908, p. 343. Harris 1911, p. 7. Leng 1920, p. 40.

Cicindela amoena LeConte 1848, p. 177 (type locality-Western Missouri). LeConte 1856, p. 37. Schaupp 1883, p. 90. Wickham 1899, p. 216 and 1911, p. 5. Leng 1902a, p. 135 and 1920, p. 40. Lantz 1905, p. 256. Smyth 1907, p. 180; 1933, p. 202 and 1935, p. 44. Horn 1908, p. 373. Harris 1911, p. 8. Casey 1913, p. 8 and 22. Harris and Leng 1916, p. 5. Fackler 1918, p. 37. Varas-Arangua 1928, p. 238. Nicolay and Weiss 1932, p. 347. Meserve 1936, p. 271. Blackwelder 1939, p. 7. Huber 1969a, p. 18. Rump 1980, 32 pp. Boyd and Associates 1982, p. 8. Wilson and Brower 1983, p. 10.

Cicindela spreta LeConte 1848, p. 177 (type locality-Eastport, Maine). LeConte 1856, p. 37. Schaupp 1883, p. 90. Wickham 1899, p. 216. Leng 1902a, p. 132; 1912, p. 13 and 1920, p. 40. Davis 1903, p. 272. Horn 1908, p. 373. Harris 1911, p. 6. Casey 1913, p. 8 and 22. Harris and Leng 1916, p. 4. Frost 1920, p. 229. Varas-Arangua 1928, p. 243. Nicolay and Weiss 1932, p. 349. Smyth 1935, p. 16. Blackwelder 1939, p. 7. Wallis 1961, p. 42. Huber 1969a, p. 18. Cutler 1969a, p. 7. Wilson 1970a, p. 18. Rump 1980, 32 pp. Boyd and Associates 1982, p. 8.

Cicindela splendida LeConte 1856, p. 36. Horn 1908, p. 374. Harris and Leng 1916, p. 5. Leng 1920, p. 40. Blackwelder

1939, p. 7. Rumpp 1980, 32 pp. Boyd and Associates 1982, p. 8.

Cicindela transversa Leng 1902a, p. 131 (type locality-Illinois and New Jersey). Smyth 1907, p. 180; 1933, p. 201 and 1935, p. 16. Horn 1908, p. 373 and 1938, p. 48. Harris 1911, p. 7. Wickham 1911, p. 5. Leng 1912, p. 13 and 1920, p. 40. Casey 1913, p. 8 and 22. Harris and Leng 1916, p. 4. Shelford 1917, p. 448. Fackler 1918, p. 37. Varas-Arangua 1928, p. 238. Nicolay and Weiss 1932, p. 348. Nicolay 1934, p. 130. Meserve 1936, p. 271. Blackwelder 1939, p. 7. Eckhoff 1939, p. 213. Rivalier 1954, p. 253. Huber 1969a, p. 25. Cutler 1969a, p. 5. Willis 1970, p. 4. Lawton 1972, p. 36. Larochelle 1978, p. 35. Johnson 1979, p. 26 and 1983, 14 pp. Rumpp 1980, 32 pp. Boyd and Associates 1982, p. 8. Wilson and Brower 1983, p. 18.

Cicindela awemeana Casey 1913, p. 23 (type locality-Aweme, Manitoba, Canada). Horn 1908, p. 374. Harris and Leng 1916, p. 5. Criddle 1919, p. 101. Leng 1920, p. 40. Nicolay and Weiss 1932, p. 347. Blackwelder 1939, p. 7. Wallis 1961, p. 42. Huber 1969a, p. 21. Rumpp 1980, 32 pp. Boyd and Associates 1982, p. 8. Johnson 1983, 14 pp.

Cicindela eldorensis Casey 1913, p. 23 (type locality-Eldora, Colorado, U.S.A.). Horn 1908, p. 374. Harris and Leng 1916,

p. 5. Leng 1920, p. 40. Nicolay and Weiss 1932, p. 348.
Blackwelder 1939, p. 7. Huber 1969a, p. 21. Rumpp 1980, 32
pp. Boyd and Associates 1982, p. 8.

Cicindela militaris Varas-Arangua 1928, p. 242 (type
locality-Connecticut, New York and Rhode Island). Nicolay
and Weiss 1932, p. 348. Leng and Mutchler 1933, p. 9.
Blackwelder 1939, p. 7. Huber 1969a, p. 22. Rumpp 1980, 32
pp. Boyd and Associates 1982, p. 8.

3. The species *Cicindela denverensis* Casey

Cicindela denverensis Casey 1897, p. 297 (type locality-
Denver, Colorado). Wickham 1899, p. 216. Leng 1902a, p.
132; 1902b, p. 133 and 1920, p. 40. Lantz 1905, p. 256.
Smyth 1907, p. 183; 1933, p. 198 and 1935, p. 15. Horn 1908,
p. 373 and 1938, p. 48. Harris 1911, p. 7. Casey 1913, p.
8; 1914a, p. 20 and 1914b, p. 357. Harris and Leng 1916, p.
4. Shelford 1917, p. 443. Fackler 1918, p. 38. Knaus 1922,
p. 195. Varas-Arangua 1928, p. 240. Nicolay and Weiss 1932,
p. 352. Nicolay 1934, p. 129. Meserve 1936, p. 271.
Blackwelder 1939, p. 7. Rivalier 1954, p. 253. Drew and Van
Cleave 1961, p. 116. Wallis 1961, p. 45. Willis 1968, p.
316; 1970, p. 3 and 1972, p. 13. Huber 1969a, p. 18. Lawton
1972, p. 35. Freitag 1974, p. 564. Acciavatti 1979, p. 30.
Rumpp 1980, 32 pp.; 1981, 10 pp.; 1983, p. 1 and 1984, 9 pp.
Boyd and Associates 1982, p. 8. Johnson 1983, 14 pp.

Hilchie 1985, p. 329.

Cicindela graminea Casey 1913, p. 21. Horn 1908, p. 373.
Harris and Leng 1916, p. 4. Leng 1920, p. 40. Blackwelder
1939, p. 7. Rumpp 1980, 32 pp. Larson 1981, p. 52. Boyd
and Associates 1982, p. 8.

Cicindela conquisita Casey 1914b, p. 357 (type locality-Sioux
Co., Nebraska). Harris and Leng 1916, p. 4. Leng 1920, p.
40. Varas-Arangua 1928, p. 241. Smyth 1935, p. 16. Meserve
1936, p. 271. Horn 1938, p. 48. Blackwelder 1939, p. 7.
Huber 1969a, p. 21. Rumpp 1980, 32 pp. Larson 1981, p. 52.
Boyd and Associates 1982, p. 8.

Cicindela oreada Casey 1914b, p. 358 (type locality-
Benkleman, Nebraska). Harris and Leng 1916, p. 4. Leng
1920, p. 40. Varas-Arangua 1928, p. 241. Meserve 1936, p.
271. Blackwelder 1939, p. 7. Huber 1969a, p. 21. Rumpp
1980, 32 pp. Boyd and Associates 1982, p. 8.

Cicindela plattensis Smyth 1933, p. 202 (type locality-in the
Valley of the South Platte). Smyth 1935, p. 16. Horn 1938,
p. 48. Blackwelder 1939, p. 7. Huber 1969a, p. 20. Rumpp
1980, 32 pp. and 1981, 10 pp. Boyd and Associates 1982, p.
8.

Distribution

In the following distribution records, the number of specimens and the collection where they are housed is indicated in brackets for specimens I have seen. The distribution of these species based on these records is illustrated in Figure 74.

The species *Cicindela splendida* Hentz

United States. **ARKANSAS:** no locality given (3, AMNH; 1, CAS; 1, LACM; 1, USNM), Benton County: no locality given (2, UAF), Rogers (7, KSU), Franklin County: Ozark (1, UNL), Garland County: Hot Springs National Park (1, PSU; 6, USNM), Hempstead County: Hope (2, CAS; 1, FMNH; 8, MCZ; 3, SMEK; 1, UAE; 48, USNM), Jefferson County: Pine Bluff (5, USNM), Johnson County: no locality given (1, UAF), Lawrence County: no locality given (1, CAS), Imboden (1, LACM), Lincoln County: no locality given (3, FMNH), Logan County: no locality given (3, UAF), Miller County: no locality given (1, LACM), Perry County: Aplin (8, CAS), Pike County: Delight (1, FMNH), Union County: Giant City State Park (1, INHS), Washington County: no locality given (13, UAF), Cove Creek Valley (2, UAF), Fayetteville (1, KSU), Winslow (1, MCZ; 1, UVB). **COLORADO:** no locality given (1, AMNH; 2, CAS; 1, FMNH; 1, KSU; 4, MCZ; 1, USNM), Bent County: Las Animas, West (1, MCZ), Boulder County: Boulder (2, MCZ), Denver County: Denver (1, LACM; 3, MCZ; 1, USNM), Jefferson County:

Golden (1, AMNH), Morgan County: Brush (1, AMNH). Localities of unknown counties: Berkley (4, MCZ), Fort Hills, Polson (2, MCZ), Oslar (3, AMNH), Oslar, Clear Creek (1, CAS), Regnier (1, AMNH). **DISTRICT OF COLUMBIA:** no locality given (3, AMNH; 1, CNC; 4, MCZ), Rock Creek, Washington (6, USNM). **GEORGIA:** Rabun County: Clayton (1, AMNH). Localities of unknown counties: Chimney Campia (1, UAE), Satolah (1, AMNH; 2, USNM). **ILLINOIS:** no locality given (1, CAS), De Kell County: no locality given (1, INHS), Jo Daviess County: Elizabeth (2, INHS), Galena (2, AMNH; 1, INHS), Kane County: Elgin (1, CNC), Elizabeth Hill, Elgin (4, FMNH), Lake County: Volo (5, BGSU; 2, WJ), Volo Bog Area (3, BGSU; 1, LACM), Pope County: Herod (10, INHS), Putnam County: no locality given (5, INHS), St. Clair County: no locality given (3, USNM). Localities of unknown counties: Edgemont (1, USNM), Makanda (2, UVB), South Rock (1, INHS). **IOWA:** no locality given (1, FMNH), Clayton County: Guttenberg (4, USNM), Dubuque County: Holy Cross (1, ISU). **KANSAS:** no locality given (2, AMNH; 1, CAS; 1, CSU; 2, FMNH; 2, INHS; 1, KSU; 2, LACM; 16, MCZ; 1, UMSP; 6, USNM), Bourbon County: Fort Scott (1, USNM), Clay County: no locality given (1, LACM; 7, MCZ; 10, UMAA; 3, USNM), Douglas County: no locality given (17, AMNH; 1, LACM; 1, NDSU; 4, SMEK), Baldwin City (4, SMEK), Lawrence (1, AMNH; 1, CNC; 1, LACM; 2, UWM), near Lecompton, Rd. 1029 (12, LU), Ellis County: Fort Hays (1, MCZ), Hays (13, KSU), Ellsworth County: no locality given (1, NDSU), Ellsworth (6, KSU),

Franklin County: no locality given (1, KSU; 1, UMAA), Gove County: Grainfield (3, USNM), Harvey County: Sedgwick (2, MCZ), Johnson County: De Soto (1, SMEK), Leavenworth County: Leavenworth (5, USNM), McPherson County: McPherson (4, AMNH; 2, CAS; 2, CNC; 1, INHS; 17, KSU; 10, LACM; 18, MCZ; 4, UAE; 4, UMAA; 6, USNM), Turkey Creek, 10 mi. S. of McPherson (1, KSU), Montgomery County: Coffeyville (1, SMEK), Elk City (1, SMEK), Ottawa County: Delphos (2, KSU), Pottawatomie County: no locality given (1, AMNH; 1, UAF), Onaga (1, AMNH; 31, CAS; 1, CNC; 4, INHS; 1, LACM; 18, MCZ; 2, SMEK; 1, UMAA; 9, USNM; 3, UWM), Reno County: Sylvia (1, UAE), Riley County: no locality given (115, KSU; 1, MCZ; 1, SMEK; 12, USNM), Manhattan (7, AMNH; 1, CNC; 3, CSU; 12, INHS; 15, KSU; 5, MCZ; 5, UAF; 6, USNM; 1, UVB; 2, WSU), Saline County: Salina (1, KSU), Sedgwick County: no locality given (2, INHS; 4, UMAA), Shawnee County: Topeka (5, AMNH; 1, BGSU; 20, CAS; 1, FMNH; 9, INHS; 4, KSU; 2, LACM; 18, MCZ; 3, SMEK; 5, UMAA; 18, USNM), Trego County: no locality given (1, USNM), WaKeeney (2, AMNH; 2, MCZ), Wyandotte County: no locality given (2, AMNH; 2, LACM; 2, UMAA). Localities of unknown counties: Argentine (3, CAS; 1, CNC; 4, INHS; 7, LACM; 2, MCZ; 5, UMAA; 9, USNM), Garrison (1, KSU), Haysly (1, KSU), Mount Hope (1, LACM), St. George (1, KSU), Snow (2, CNC; 2, INHS; 2, USNM; 1, UVB), Sunflower (1, USNM), Williston (1, USNM). KENTUCKY: no locality given (1, AMNH), Edmonson County: Bee Spring (1, LACM; 1, MCZ), Jefferson County:

Louisville (1, LACM; 2, MCZ; 11, USNM). LOUISIANA: no locality given (2, MCZ; 1, USNM), Caddo County: Shreveport (2, AMNH; 1, LACM; 1, PSU; 2, USNM), Grant County: Montgomery (2, USNM), Natchitoches County: Vowells Mill (1, labeled "topotype" April/May ludoviciana Leng, USNM; 2, labeled "cotype" ludoviciana Leng, AMNH; 2, AMNH; 1, KSU; 5, MCZ; 2, PSU), Sabine County: Zwolle (2, PSU). Localities of unknown counties: Hunter (1, PSU). MARYLAND: no locality given (1, UMSP), Prince Georges County: Bladensburg (1, USNM). MINNESOTA: Fillmore County: no locality given (5, CAS; 2, NDSU), Houston County: no locality given (1, BGSU; 84, CAS; 2, CNC; 2, FMNH; 3, LACM; 10, NDSU; 25, UMSP; 3, USNM), Gwinns Bluff (5, UMSP), Houston, 4.5 miles S. (12, WJ), Winona County: no locality given (3, CAS; 3, NDSU). Localities of unknown counties: Lake Minnetonka (2, CAS). MISSOURI: no locality given: "C.Mo.", Central Missouri? (1, USNM), Greene County: Willard (1, MCZ; 2, UAE), St. Francis County: no locality given (1, UVB), Knob Lick (2, UVB), St. Louis City County: Eureka (3, MCZ), St. Louis (2, MCZ; 1, USNM), Taney County: Forsyth (12, AMNH; 2, LACM; 1, MCZ). Localities of unknown counties: Blue Eye (1, USNM), Iron Mountain (2, UVB), Kimmswick (2, FMNH), Ozark Lake (8, CAS), Pickle Springs (1, AMNH). NEBRASKA: no locality given (1, CMP; 1, FMNH; 4, MCZ), Boone County: Loretto (3, CAS), Butler County: no locality given (1, NDSU), Cass County: Louisville (1, UNL), Weeping Water (2, UNL), Douglas County:

Omaha (2, AMNH; 5, CAS; 3, CNC; 1, INHS; 6, MCZ; 10, UMAA; 9, UNL; 1, UWM), Dundy County: Benkelman (1, KSU; 1, MCZ), Furnas County: Cambridge (1, NCSR), Lancaster County: Bennet (3, AMNH; 196, NCSR; 6, USNM), Lincoln (1, AMNH; 4, CAS; 1, CNC; 1, LACM; 14, MCZ; 1, NCSR; 28, UMAA; 12, UNL; 4, USNM; 1, UWM; 2, WSU), Nemaha County: Brownville (2, WSU), Peru (1, NCSR), Otoe County: Dunbar (1, NCSR), Polk County: Osceola (11, LU), Sarpy County: Bellevue (1, CAS; 1, MCZ), Stanton County: no locality given (3, NDSU). Localities of unknown counties: Austin (1, LACM), Hwy. 238 & 23, Elwood Lake Rec. Hydro Power Irrig. (5, LU), Malcolm (2, AMNH; 1, CAS; 1, CNC; 1, INHS; 3, NDSU; 6, LACM; 14, MCZ; 4, UMAA; 16, USNM), Roca (1, MCZ; 1, UNL). **NEW MEXICO:** Colfax County: Maxwell (1, USNM), Roosevelt County: Portales (4, WSU). **NEW YORK:** no locality given (1, MCZ). **NORTH CAROLINA:** no locality given (3, AMNH; 1, INHS; 1, LACM; 2, MCZ), Buncombe County: Asheville (6, AMNH; 9, CAS; 1, CNC; 1, FMNH; 4, INHS; 15, LACM; 28, MCZ; 1, UAE; 15, UMAA; 4, USNM), Black Mountain (1, MCZ), Sunset Mountain, Asheville (4, AMNH), Cherokee County: Andrews (1, CUSC; 2, KSU; 1, NCSR; 1, USNM), Murphy (1, USNM), Orange County: Chapel Hill (1, USNM), Polk County: Tryon (1, AMNH), Rockingham County: Reidsville (1, MCZ), Swain County: Smoky Mountains, Bryson City (1, LACM), Wake County: Raleigh (1, NCSR; 1, USNM). Localities of unknown counties: Balsam (2, USNM), Dillsboro (1, AMNH), Jones Knob (3, CNC; 1, FMNH; 3, LACM; 2, USNM),

Sunburst (4, CUSC; 1, NCSR; 6, USNM). OHIO: Preble County: Eaton (1, KSU), Vinton County: Zaleski Forest (1, CAS).

OKLAHOMA: no locality given (1, WSU), Delaware County: no locality given (1, BM), Cleveland County: Norman (1, CNC), Kingfisher County: Kingfisher (3, KSU; 4, UMAA), Latimer County: no locality given (1, CAS), Leflore County: Wister (1, USNM), Marshall County: no locality given (5, FMNH), Oklahoma County: Oklahoma City (2, CAS; 1, WSU), Osage County: no locality given (1, UMAA), Payne County: no locality given (1, FMNH; 3, KSU), Stillwater (1, AMNH; 1, LACM), Tulsa County: Tulsa (1, LACM). Localities of unknown counties: Hitchcock (1, INHS). PENNSYLVANIA: Dauphin County: Linglestown (1, INHS; 1, MCZ). SOUTH CAROLINA: Florence County: Florence (1, CUSC), Oconee County: no locality given (4, CUSC; 1, FMNH; 1, MCZ; 1, NCSR; 4, USNM), Walhalla Tunnel (2, AMNH; 30, CUSC; 4, USNM). Localities of unknown counties: Jocasse (3, AMNH; 10, USNM), Mountain Rest (1, CUSC). TENNESSEE: no locality given (1, USNM), Morgan County: between Deer Lodge & Sunbright (3, FMNH), Sevier County: Gatlinburg (1, INHS; 2, USNM). Localities of unknown counties: Burrville (1, USNM), Deer Lodge (2, FMNH), Great Smoky Mountains National Park (1, AMNH; 1, FMNH). TEXAS: no locality given (2, AMNH; 1, CAS; 1, CNC; 2, FMNH; 13, INHS; 1, KSU; 2, LACM; 10, MCZ; 1, UMAA; 2, UMSP; 2, UNL; 7, USNM; 1, WSU), Bastrop County: no locality given (1, PSU), Bastrop State Park (3, AMNH), Brazos County: no locality given (1,

INHS), College Station (1, AMNH; 1, FMNH; 1, ISU), Dallas County: no locality given (3, INHS), Dallas (2, LACM; 8, MCZ; 5, USNM), Eastland County: no locality given (1, UMSP), Galveston County: Galveston (3, FMNH), Grimes County: Bedias (2, USNM), Kaufman County: no locality given (1, USNM), Lee County: no locality given (1, UAE), Lexington (6, INHS; 2, LACM; 1, USNM), Limestone County: no locality given (4, CNC; 1, USNM), Milan County: no locality given (4, CAS), Nacogdoches County: Nacogdoches (2, SMEK), Roberts County: Miami (2, CAS). Taylor County: Abilene (3, FMNH), Travis County: Austin (1, WSU). Localities of unknown counties: Forestburg (1, AMNH). VIRGINIA: no locality given (2, MCZ), Alleghany County: Clifton Forge (1, USNM), Long Dale, Alleghany (1, AMNH), Bath County: Hot Springs (1, USNM), Fairfax County: Falls Church (4, USNM), Mount Vernon (2, AMNH; 5, LACM; 1, MCZ; 2, UAE; 8, UMAA; 36, USNM), Lancaster County: Irvington (1, USNM), Montgomery County: no locality given (1, USNM), Blacksburg (1, USNM), Rockbridge County: no locality given (1, UMAA), Spotsylvania County: "Four Mile Run", Four Mile Fork? (1, USNM), Suffolk County: Suffolk (1, AMNH; 10, MCZ), Sussex County: no locality given (1, VPI). Localities of unknown counties: Alexan (2, USNM), Bancroft (1, USNM), Glencarlyn (2, USNM), Hunter (1, USNM). WISCONSIN: Grant County: no locality given (2, FMNH; 12, SMEK; 4, USNM), Vernon County: no locality given (24, NDSU).

Doubtful or Unusable Records

Canada: Saskatchewan, Moose Jaw (1, CAS). United States: Localities of unknown counties: Hopk. (1, USNM), Indian Cave (1, USNM), Or. Ex. Sta. Lot 2 (1, USNM). No localities given: (10, AMNH; 9, CAS; 2, INHS; 16, KSU; 2, MCZ; 2, NCSR; 4, SMEK; 3, UMSP; 2, USNM).

Records from Literature Cited

Boyd and Associates (1982) also list Alabama, Indiana, Mississippi, West Virginia and Wyoming in the distribution of *C. splendida*, and Wisconsin as one of the states in the distribution of *C. splendida cyanocephalata*. Graves and Pearson (1973) also list Mississippi in the distribution of *C. splendida*. Since I have not seen any specimens from these aforementioned states, they are not included in the distribution map (Fig. 74).

The species *Cicindela limbalis* Klug

Canada: no locality given: (1, CMP). ALBERTA: Beaverhill Lake (1, LU), "Bilby", Gilby? (2, CAS), Boss Hill, NE. of Buffalo Lake (5, PMA), Calgary (5, CNC; 2, EJK; 6, MCZ; 1, ROM; 1, UAE; 4, USNM), Edmonton (2, AMNH; 16, CAS; 2, CNC; 1, FMNH; 1, KSU; 1, LACM; 2, LEM; 9, LU; 8, MCZ; 4, MPM; 14, PMA; 27, ROM; 27, UAE; 4, UGA; 22, UMAA; 7, USNM; 4, WJ), Edmonton, Terwilligar Park (14, PMA), Devon (8, PMA), Elk Island (1, UAE), Elk Island National Park (1, UAE), Fawcett (1, UAE), Flatbush (1, LU), Fort MacKay (3, WJ), Fort MacKay, 4.5 km N. of bridge (2, PMA), "Ft. McLeod", Fort MacLeod? (2, USNM), "McMurray", Fort McMurray? (20, CNC), Fox Creek, 11 miles NE. on route 43 (1, UAE), Garth (1, LU), George Lake (1, LU; 4, PMA; 1, UAE), Heatherdown (1, UAE), Nestow (2, UAE), Nestow, Typha Marsh (1, UAE), Opal (1, LU), Pincher (1, UAE), Prairie Bluff Mountain (2, UAE), Red Deer (1, CNC; 1, CU; 1, MCZ; 1, PMA), Redwater (1, PMA; 2, UAE), Spring Creek Basin (1, UAE), Smoky Lake (1, UAE), Sundance (1, UAE), Sylvan Lake (1, UGO), Tawatinaw (1, UAE), Thickwood Hills Lookout, 6.5 km E. along road (5, PMA), Wabamun (1, LU; 9, UAE), "Whitemud Park", Whitemud River? or Whitemud Creek, Edmonton? (10, PMA; 1, UAE), Winterburn (3, PMA). BRITISH COLUMBIA: no locality given (1, LEM), Neehako River, near Fort Fraser on route 16 (1, UAE), Pouce Coupe (1, UAE), Quesnel (1, CNC), Rolla (1, CAS), Ruth Lake, 3 miles N. of Forest Grove (6, PSU). MANITOBA: Assessippi (1, PMA), Aweme

(Treesbank) (4, AMNH; 4, CAS; 9, CNC; 1, INHS; 1, KSU; 1, LEM; 9, MCZ; 1, ROM; 2, UGO; 5, UMAA; 12, USNM), Crawford Creek (1, UMW), Delta (1, UGO), Fort Whyte, Winnipeg (1, CNC), Garson (3, UMW), Hudson Bay (2, AMNH), Kilarney (1, CMP), Makinak (2, MCZ), Miami (1, LEM; 1, USNM), "Mile 332, H.B.Ry." (1, AMNH; 4, CNC; 1, LACM; 1, MCZ; 4, UCB; 1, UMAA), Minto (2, LU), Morton Municipality (6, NDSU), Ninette (17, CNC), Oak Lake, 4 miles W. on Hwy. 1 (1, CNC), Riding Mountain Park (5, CNC; 1, PMA), Riverside (5, UAE), Riverside Municipality (8, NDSU), Rosser (2, UMW), Seven Sisters (2, UMW), Shell River (1, CNC), Slave Falls (1, PMA), Strathcona County (1, NDSU), Turtle Mountain Municipality (46, NDSU), Wasagaming, Catherine Lake Campground, Riding Mountains National Park (9, ROM), Wawanesa (6, CNC), Westbourne (1, USNM), Whiteshell Provincial Park, Assinica Trail (1, LU), Winchester Municipality (1, NDSU), Winnipeg (2, CNC; 1, MCZ; 5, UMW; 1, USNM), Winnipeg Beach (1, UMW). **NEW BRUNSWICK:** Frederickton (1, LEM), "F'ton", Frederickton? (1, UGO), St. John (1, INHS). **NEWFOUNDLAND:** Bay of Islands (1, AMNH). **NORTHWEST TERRITORIES:** Fort Norman, McKenzie River (1, CNC), Fort Wrigley, McKenzie River (1, CNC), Hay River (1, CNC), Martin River, 10 miles NW. of Fort Simpson (1, CNC), Norman Wells (25, CNC). **NOVA SCOTIA:** Baddeck, Cape Breton Island (1, AMNH; 1, CSU; 2, LACM; 2, MCZ), Boisdale, Cape Breton Island (1, AMNH; 1, MCZ), Bras d'Or Lake (1, FMNH), Cape Breton (4, MCZ), Cape Breton Island (5, CMP), Kelly's Cove,

Cape Breton Island (2, LACM), Margaree, Cape Breton Island
 (1, LACM), North Sydney (11, CNC). ONTARIO: no locality
 given (2, LACM), Algoma District, Batchawana Provincial Park
 (1, ROM), Algoma District, Thessalon (2, LEM), Belle River
 (1, SUNY), Brighton (1, LEM), Caliper Lake Provincial Park,
 30 Kilometers N. on Hwy. 71 (1, LU), Chaffeys Locks (4, ROM),
 Charlton (9, AMNH; 1, CU; 1, OKS; 2, UIM; 4, USNM), Cochrane
 (2, FEM), Current River near Port Arthur, Thunder Bay (2,
 LU), Dorset (1, CSU), Dryden, 19 miles W. (4, CNC), Fort
 William, Thunder Bay (1, CMP; 1, LU; 8, UNL), French Lake (3,
 LU), French Lake, Campsite Road (2, LU), Frontenac County,
 Perth Road (1, CNC), Goderich, Huron County (1, AMNH; 1, OKS;
 1, ROM; 1, SMEK; 4, UAE; 1, UGO; 3, UMAA), "Goodrich",
 Goderich? (7, CAS), Guelph (1, CNC), Huron County: no
 locality given (2, UMAA), Inwood Park, 2 miles SE. of Upsala
 (1, AMNH), Kapuskasing (1, CNC), Kenora, 50 km E. (12, LU),
 Kenora, SE. (111, CAS; 4, UCB), Kenora, 15 miles SE., Rushing
 River Provincial Park (15, CAS; 10, UCB), Kent County, 5
 miles W. of Point Alma (4, BGSU), Loon Lake, near Fort
 William, Thunder Bay (2, LU), "McIntyre", McIntyre River? (1,
 LU), Nakina (2, CNC; 12, ROM), Nipigon (5, CMP; 1, MCZ),
 Nipigon, Ombabika Bay (3, CMP), Nipigon, Orient Bay (2, CMP),
 Normandale (1, CNC), Ogoki (12, CNC), Penage Lake (1, UGO),
 Port Arthur, Thunder Bay (10, LU), Quibell (1, UGO), Red
 Lake, 20 miles N. (6, CNC), Reta Lake, unused road E. of lake
 (5, LU), Sandstone Lake (4, LU), Sarnia, Lampton County (2,

UMAA), Sault Ste. Marie, Algoma (5, ROM), Shebandawan (2, LU), Sibley Peninsula, MacLean's Road, 1 km E. of Knutsen's Corner (5, LU), Sioux Lookout (1, CMP; 1, CNC; 3, ROM), Smoky Falls, Kapuskasing (3, ROM), Smoky Falls, Mattagami River (3, CNC), Stanley, Thunder Bay District (9, LU), Stanley, Stanley Hill Cemetary, 26 km W. of Thunder Bay (5, LU), Stouffville (1, UGO), Sudbury (9, CNC; 1, CU; 1, ROM), Timiskaming District, Kap-Kig-Iwan Provincial Park, Englehart (1, ROM), Thunder Bay (4, LU; 1, UGO; 9, USNM), Thunder Bay, Community Hall Road, 1 km S. of John St. Road (14, LU), Thunder Bay, Kaministiquia River in Vickers Heights (324, LU), Thunder Bay, Riverdale Road and 25th Side Road at City Limits (7, LU), Thunder Bay, Slate River Area (3, LU), Thunder Bay District, various roadside localities given (21, LU; 1, ROM), Thunder Bay District, Rosslyn Brick Yard near Rosslyn Village (307, LU), Thunder Bay District, Spruce River Road (15, LU), Toronto (3, ROM; 1, UGO; 1, USNM), Toronto, Don Valley (1, ROM), Wabigoon (1, CNC). QUEBEC: Cap Rouge (5, CC), Charlevoix County (2, AMNH), Covey Hill (3, CNC), Duparquet (23, CAS; 4, MCZ), Ile Nippawa (1, CNC), Island of Montreal (1, KSU; 1, MCZ; 2, UWM), Kazubazua (1, CNC), Knowlton (5, CNC), Laniel (1, CNC), Levis (3, LEM), Montreal (2, AMNH; 4, CAS; 1, INHS; 4, LACM; 4, LEM; 20, MCZ; 2, SMEK; 4, UWM), Mount Royal (4, MCZ; 1 UAE), Old Chelsea (2, CNC), Opatatika Lake (1, CNC; 1, USNM), Pincourt, Ile Perrot (4, LEM), Pt-Aux-Saumons (3, CNC), St. Augustin, Portneuf (6, CC),

Wakefield (3, CNC). **SASKATCHEWAN:** Asquith (1, CNC), Attons Lake, Cut Knife (1, CNC), Christopher Lake (1, CNC), Cutknife (2, CNC), Duck Mountain Park (1, SMNH), Fort Qu' Appelle (1, SMNH), Gull Lake (1, PMA), Kenosee, Moose Mountain Park (2, CNC), Moose Jaw (3, CNC), Moose Mountain Park (2, SMNH), Outlook (1, NDSU), Pike Lake (1, CNC), Saskatoon (14, CNC; 2, MCZ; 1, UGA), Swift Current (1, CAS; 9, CNC), Tantalion (1, SMNH), Torch River (16, CNC), Torch River, White Fox (6, CNC; 1, MSUB), Turtleford (1, SMNH), North Battleford (2, CNC; 1, ROM), Roche Percee (3, CNC), Waskwei River (3, SMNH), Whitefox (1, CNC), Yorkton (4, MCZ).

United States. **COLORADO:** no locality given (1, labeled "cotype" C. transversa Leng, plus 2 additional specimens, AMNH; 1, CMP; 1, INHS; 9, MCZ; 1, SMEK; 3, USNM), Boulder County: Rocky Mountain National Park, Meeker Park (2, CAS; 1, LACM; 6, MCZ; 1, REA), Denver County: Denver (1, CAS), Douglas County: no locality given (64, NDSU; 10, SMEK), Sedalia (50, USNM), Sedalia, 2 miles E. on Hwy. 85 (2, DWB), Elpaso County: Cascade (1, MCZ; 1, USNM), Garfield County: Glenwood Springs (1, MCZ), Grand County: Elk Creek (1, CU), Fraser (2, MCZ), Grand Lake (2, REA), Rocky Mountain National Park, Timber Creek (1, CAS), Huerfano County: East Spanish Peak (2, UMAA), La Veta (1, UMAA), Jefferson County: Golden (1, CU; 2, MCZ), Larimer County: no locality given (3, CSU; 4, CU; 2, LU; 1, PSU; 2, SMEK; 1, UGA; 1, USNM), Fort Collins (1, CSU), Hewleit Gulch (2, CSU), Poudre River,

12 miles NW. of Fort Collins (1, AMNH), Rist. Canu. (1, CSU), Rocky Mountain National Park, Estes Park, Windriver Trail (5, CAS; 1, CU; 1, KSU; 1, LACM; 7, MCZ; 1, OKS; 2, USNM), Moffat County: Pine Cliff (8, UMAA), Routt County: Hwy. 84 (4, MPM), Steamboat Springs (1, CAS). Localities of unknown counties: Beulah (1, AMNH), Camp Creek R. Sta. (1, USNM), Horsefly Park divide Placerville Road, San Miguel (1, MCZ), Jamestown (2, CAS), Masonville (7, CSU), National Forest Hot Spring (1, CMP), Pingree Park (1, SMEK), Rainbow Lake (1, FMNH), Red Feather Lakes (2, AMNH), University of Colorado Science Lodge (2, SMEK), Veta Pass (1, USNM), Virginia (1, CAS), Willow Pass (1, MCZ). CONNECTICUT: Fairfield County: New Haven (1, CAS; 1, CU; 1, UGG; 1, USNM), Litchfield County: no locality given (1, USNM), New Haven County: Meriden (3, CDAS). ILLINOIS: no locality given (2, CAS; 1, FMNH; 4, INHS; 1, MCZ; 1, UGO; 1, UMSP; 1, UNL; 1, USNM), North Illinois, no locality given (2, AMNH; 2, CMP; 2, CU; 3, INHS), South Illinois, no locality given (1, CAS), Carroll County: Mount Carroll (1, INHS), Kane County: Elgin (23, IL), Lake County: Burneit and Darrell Roads (1, IL), Highland Park (1, AMNH; 1, BGSU; 1, UMAA), Ravinia (1, AMNH; 3, CNC; 4, INHS; 1, LACM; 3, MPM; 1, MCZ; 3, UMAA; 1, USNM), Volo (93, BGSU; 224, IL; 7, WJ), Volo, NW. of Lake County (1, BM; 5, LACM), Volo Bog Area, NW. of Lake County (1, BM; 2, CDAS; 81, IL; 19, LACM), Pope County: Herod (1, INHS), Putman County: no locality given (2, INHS), Winnebago County:

Rockford (1, BGSU; 2, FMNH). Localities of unknown counties: Beach (1, AMNH), Chicago (4, CAS; 1, CMP; 1, CNC; 3, CU; 1, LACM; 5, LSU; 2, MCZ; 2, MPM; 7 UMAA; 8, USNM), Edgebrook (1, USNM), Edgemont (2, UMAA; 1, USNM), Evanston (2, FMNH), Fort Sheridan (8, CAS; 1, MCZ; 1, UMAA), Galesburg (2, CMP; 1, UWM), Glencoe (2, AMNH; 1, BGSU; 9, CAS; 29, INHS; 1, LACM; 1, MCZ; 16, UMAA), Lake Forest (6, AMNH; 3, CNC; 3, FEM; 2, FMNH; 28, INHS; 5, MCZ; 3, MPM; 3, UMAA; 2, USNM), Moline (1, INHS), Moosville (1, MCZ), Quincy (1, AMNH; 6, USNM), Willowsprings (4, CAS). IOWA: no locality given (1, AMNH; 2, CAS; 8, MCZ; 2, UMSP; 3, USNM), Boone County: Ledges State Park (2, ISU), Decatur County: Leon (2, ISU; 1, USNM), Dickinson County: East Okoboji (2, ISU), Henry County: Mount Pleasant (3, LEM; 1, OKS; 1, UMAA; 3, USNM), Jackson County: Maquoketa (2, ISU), Johnson County: Iowa City (9, AMNH; 13, CAS; 7, CMP; 1, CNC; 2, CU; 1, FEM; 1, FMNH; 9, INHS; 23, MCZ; 1, MSUB; 2, UCB; 11, UNL; 17, UMAA; 46, USNM), Iowa City, Clear Creek (2, CAS; 3, UCB), North Liberty (1, USNM), Lee County: Fort Madison (1, CNC; 2, FEM; 4, FMNH; 1, INHS; 1, MCZ; 1, UGO; 5, USNM), Lyon County: no locality given (4, INHS), Scott County: Davenport (1, ISU), Story County: Ames (2, CAS; 1, CMP; 1, CSU; 8, ISU; 3, MSUB; 5, NCSR; 8, USNM; 1, UWM), Webster County: Dolliver Memorial State Park (2, ISU), Woodbury County: no locality given (3, NDSU), Holly Springs, 3 miles ESE. (1, ISU), Hornick, 4 miles ENE. (8, UMSP), Sioux City (28, ISU; 2, LEM; 1, MCZ; 2, UMAA; 5, UMSP;

69, USNM). Localities of unknown counties: #52 Penn-20 (14, CAS), Bethlehem (1, ISU), County 87 (1, FEM), County 88 (1, UMAA), County 89 (1, UMAA), County Bluffs (1, INHS; 2, UMAA), Dundee (1, ISU); Glasgow (1, UMAA), Holy Cross (1, ISU), Kingston (1, ISU), Orleans (1, ISU). KANSAS: no locality given (1, CSU; 1, INHS; 11, MCZ; 3, USNM), Brown County: Brown County State Park (5, UCB), Douglas County: Lawrence (1, MCZ), Johnson County: no locality given (1, BGSU), Leavenworth County: Leavenworth (1, MCZ; 3, USNM), Osborne County: Osborne (1, USNM), Pottawatomie County: Onaga (1, CAS; 1, UMAA), Reno County: Sylvia (2, CAS), Riley County: no locality given (1, USNM), Sedgwick County: no locality given (1, FMNH; 2, INHS), Shawnee County: Roy Ranch, Topeka (1, KSU), Topeka (1, MCZ). Localities of unknown counties: Argentine (1, AMNH; 7, CAS; 1, CU; 2, INHS; 17, LACM; 32, MCZ; 1, UAE; 21, UMAA; 17, USNM). MAINE: no locality given (1, AMNH), Hancock County: Bar Harbour (1, OKS; 1, FMNH; 1, UMAA; 1, USNM), Lamoine (1, MCZ), Mount Desert (2, CAS), Mount Desert Island (8, AMNH; 1, LACM; 3, MCZ; 36, MPM; 6, REA; 51, USNM; 1, WJ), Mount Desert, Bass Harbour (1, INHS; 3, MCZ), Mount Desert, Seal Cove (2, CAS; 4, MCZ), Seal Harbour (15, MCZ), Kennebec County: Augusta (1, MCZ), Monmouth (1, LACM; 2, MCZ), Lincoln County: no locality given (1, MCZ), Damariscotta (1, SUNY), Penobscot County: Bangor and Vie. (1, LACM), Brewer (1, MCZ), "Passaduonkean," Passadumkeag? (1, USNM), Somerset County: "Indian Lake, 1

mile E.," Indian Pond? (8, LU), Washington County: East Machias (1, CAS), York County: York (1, AMNH; 2, MCZ; 1, UMSP). Localities of unknown counties: Cape Rosier (1, LACM; 2, MCZ), Isle of Springs (2, MCZ), Sipps Creek (5, LU), Wales (1, CAS; 2, MCZ). MASSACHUSETTS: no locality given (1, CMP; 1, UMAA; 1, UWM), Nantucket County: Nantucket (1, LACM). Localities of unknown counties: Boylston (1, CUSC).

MICHIGAN: no locality given (1, FMNH; 2, MCZ), Alger County: no locality given (19, NDSU), Chippewa County: Whitefish Point (1, UMAA), Dickinson County: no locality given (4, SMEK), Emmet County: no locality given (3, NDSU), Gogebic County: no locality given (5, CU; 2, FMNH; 2, LACM), Black River Park (5, BGSU), Houghton County: no locality given (2, FEM; 8, NDSU; 24, MPM), Iron County: no locality given (1, BGSU; 1, LSU; 1, VPI), Iron River (1, UAE), Mackinac County: no locality given (2, BM), St. Ignace (8, UMAA), Mecosta County: no locality given (3, NDSU), Marquette County: Lake Chabeneau, 15 miles S. of Ishpeming (2, FMNH), Ontonagon County: no locality given (21, NDSU), Saginaw County: no locality given (23, NDSU), Schoolcraft County: no locality given (1, NDSU), Wayne County: Detroit (2, CMP), Wexford County: no locality given (3, CU). Localities of unknown counties: Meguaming (1, USNM), Michigamme River (1, BGSU), Ottawa National Forest (2, LSU). MINNESOTA: no locality given: "Minn", Minnesota? (1, INHS; 1, MCZ; 1, UMSP), Aitkin County: Savanna State Forest (5, LU), Anoka County: no

locality given (4, UMSP), Blue Earth County: no locality given (1, UMSP), Carlton County: no locality given (7, BGSU), Cass County: no locality given (1, UMSP), Clay County: Comstock, 1.5 miles W. (1, CAS; 6, UCB), Moorhead (4, CAS; 3, UCB), Clearwater County: Itasca State Park (1, MCZ; 33, UMSP), Lake Itasca (3, UMSP), Cook County: no locality given (1, UMSP), Tofte (1, EJK; 1, USNM; 1, PSU), Crow Wing County: Pelican Lake, Nisswa (1, UNL), Fillmore County: Rushford, 3.5 miles N. (8, CAS; 2, NDSU; 5, UCB), Hennepin County: no locality given (1, CAS), Minneapolis (2, CU; 1, PSU; 3, UAE), Minneapolis, 0.25 miles W. of B'Way Road and St. Anthony Boulevard (47, UMSP), Houston County: no locality given (1, LACM), Houston, 1.5 miles N. (23, CAS; 10, NDSU; 4, UCB), Houston, 2.5 miles S. (13, CAS; 1, NDSU; 5, UCB), Houston, 4 miles S. (4, UMSP), Houston, 4.5 miles S. (1, CAS; 9, CDAS; 2, CNC, 4, LACM; 2, LU; 3, PSU; 1, USNM; 6, WJ), Houston, 10 miles W. (2, CAS; 2, NDSU), Beaver Creek Valley State Park (1, CAS; 3, UCB), Itasca County: no locality given (1, CDAS; 3, UMSP), Lac Qui Parle County: Lac Qui Park (2, NDSU), Lake County: Finland State Forest (11, LU), McNair, 1 mile N. (7, PSU; 1, USNM), Two Harbours (2, EJK), Two Harbours, 60 miles N. (6, PSU; 1, UWM), Marshall County: no locality given (1, NDSU), Montmorency County: no locality given (1, NDSU), Mower County: Le Roy, 0.5 miles N. (2, WJ), Nicollet County: no locality given (1, UMSP), Norman County: no locality given (1, MPM), Olmsted County:

no locality given (3, ISU), Otter Tail County: no locality given (1, NDSU), Otterti County: no locality given (1, UMSP), Pine County: Nickerson (1, PSU), Pine City, 4 miles E. on the north bank of the Snake River (13, UMSP), Snake River (1, UMSP), Polk County: no locality given (1, CAS; 7, NDSU; 5, UMSP), Ramsey County: Lauderdale, Carl St. (39, UMSP), St. Paul (3, INHS), North St. Paul (26, UMSP), U. Farm (1, UMSP), Red Lake County: Plummer (1, UMSP), Renville County: no locality given (1, CDAS; 1, PSU), Rice County: Nerstrand Woods (1, UMSP), St. Louis County: Ash River Trail, 20 miles NNE. of Kinmount (1, CDAS; 7, UMSP), Duluth (1, CMP; 4, INHS; 4, LACM; 3, MCZ; 3, USNM; 1, UMSP), Floodwood (1, UMSP), Stearns County: (2, NDSU), Todd County: (4, NDSU), Winona County: Witoka, 2.5 miles N. (4, CAS; 3, UCB), Yellow Medicine County: no locality given (1, SMEK), Granite Falls, 4 miles N. (8, WJ). Localities of unknown counties: Afton, 3 miles S. (1, NDSU), Cushing, Fish Trap Lake (1, UMSP), Detroit Lakes (1, NDSU), Lake Minnetonka (1, CAS), Lake Superior (2, UMSP), Laporte (1, UMSP), Pembina (1, UMSP). MISSOURI: no locality given (4, CMP; 3, INHS; 2, USNM; 1, UWM), Boone County: Columbia (1, CU; 1, UCD; 1, USNM), Buchanan County: St. Joseph (1, USNM), Clay County: no locality given (2, DWB), Jackson County: Kansas City (6, USNM), Pike County: Louisiana (1, labeled "cotype" transversa Leng, AMNH; 22, CAS; 2, CUSC; 1, INHS; 1, KSU; 1, MCZ; 1, UMAA; 5, USNM), St. Genevieve County: no locality

given (1, USNM), St. Louis County: Eureka (2, labeled "cotype" Apr. 30, 1905 Smyth transversa Leng, AMNH; 13, MCZ; 1, UMAA), Rankin (1, AMNH; 3, UMAA), Valley Park (1, USNM), St. Louis City County: Kirkwood (1, CAS), St. Louis (19, CAS; 1, CU; 3, MCZ; 2, SMEK; 1, UMAA). Localities of unknown counties: Darrenton (1, UIM), Overland (2, UIM), Ozark Lake (42, CAS), York Beach (1, USNM). MONTANA: Beaverhead County: no locality given (1, MSUB), Gallatin County: no locality given (3, MSUB), Bozeman (2, CAS; 6, MCZ), Gallatin National Forest, Battle Ridge Campground on Hwy. 86, 1 mile SW. (18, LU), Glacier County: no locality given (3, PSU), St. Mary, 7 miles N. on Hwy. 89 (1, WJ). Localities of unknown counties: Sedan (1, MSUB). NEBRASKA: no locality given (1, CAS; 1, INHS; 4, MCZ; 1, UMSP), Boone County: Loretto (4, CAS), Cass County: Plattsmouth (3, UNL), Douglas County: Omaha (8, CAS; 3, CNC; 20, MCZ; 19, UMAA; 21, UNL; 4, USNM), Lancaster County: Lincoln (4, UMAA; 2, UNL), Nemaha County: Peru (1, NCSR; 1, UNL), Polk County: Osceola (5, LU), Sarpy County: Bellevue (6, MPM), Bellevue, Childs' Point (7, UNL), Washington County: no locality given (11, MPM). Localities of unknown counties: Malcolm (1, labeled "homotype" compared by Frost, "nearly type amoena Lec."; plus 1 additional specimen, MCZ). NEW HAMPSHIRE: Hillsborough County: Manchester (1, INHS), Rockingham County: Exeter (1, CU; 1, CNC; 1, LACM; 7, MCZ), Strafford County: Durham (2, INHS; 1, LACM; 1, MCZ). NEW JERSEY: no locality given (1, AMNH; 3,

MCZ), Essex County: South Orange (2, labeled "cotype" transversa Leng, AMNH; 1, VPI), Monmouth County: Howell's Pond (1, USNM), Red Bank (1, WSU), Morris County: "Split Rock," Splitrock Pond? (2, USNM), Ocean County: Lakehurst (1, AMNH), Tuckerton (1, AMNH), Passaic County: Hewitt (2, USNM), Midvale (11, USNM), Paterson (1, AMNH), Greenwood Lake (2, AMNH; 3, LACM; 40, USNM). **NEW MEXICO:** no locality given (1, USNM), Colfax County: no locality given (1, MPM), Raton (2, MCZ; 1, UMAA), Taos County: Tres Ritos (2, CAS). **NEW YORK:** no locality given (1, CMP; 1, INHS; 1, MCZ; 1, USNM), Allegany County: Allegany State Park (1, CU; 9, USNM), Belfast (1, CU), Erie County: Buffalo (1, CMP), Nassau County: Cold Spring Harbor, Long Island (1, INHS), Orange County: West Point (2, AMNH; 1, CAS; 1, KSU; 10, MCZ; 17, UMAA; 28, USNM), Ramapo County: Hillburn (21, JDG), Ramapo (4, AMNH), Suffern (28, JDG; 2, WJ), Rockland County: Hillburn (3, AMNH), Suffolk County: East Hampton (1, MCZ; 1, UNL), Tompkins County: Ithaca, Six Mile Creek (1, CU; 2, FEM; 9, UAE; 1, USNM; 1, UWW), Ulster County: Oliveria (1, USNM), Westchester County: Peekskill (8, MCZ). Localities of unknown counties: Letchworth Sp. (4, CU), Montauk, Long Island, (1, FMNH), New Baltimore (2, AMNH), Plateau Mountain, Catskill Mountains (1, UAE), Quaker Bridge (1, USNM), Rock City (1, CAS; 2, CU; 3, MCZ), Storm King Mountain (1, USNM). **NORTH DAKOTA:** Adams County: no locality given (4, NDSU), Hettinger (5, WJ), Barnes County: no locality given (6,

NDSU), Benson County: no locality given (66, NDSU; 1, SMEK), Bowman County: no locality given (5, NDSU), Bottineau County: no locality given (218, NDSU), Bottineau (1, ISU), Turtle Mountains (2, NDSU), Burleigh County: no locality given (92, NDSU), Burke County: no locality given (6, NDSU), Cass County: no locality given (1, NDSU), Fargo (1, NDSU), Fargo, 8 miles NW. (1, CAS), Cavalier County: no locality given (40, NDSU), Divide County: no locality given (16, NDSU), Dunn County: no locality given (2, NDSU), Eddy County: no locality given (8, NDSU), Emmons County: Hazelton (1, LACM; 2, NDSU), Grand Forks County: Grand Forks (4, NDSU), Grant County: no locality given (42, NDSU), Hettinger County: no locality given (37, NDSU), Logan County: no locality given (11, NDSU), McHenry County: no locality given (128, NDSU), McLean County: no locality given (99, NDSU), Mercer County: no locality given (57, NDSU), Stanton (3, ISU; 15, NDSU), Morton County: no locality given (48, NDSU), Mountrail County: no locality given (3, NDSU), Pembina County: no locality given (12, NDSU), Ransom County: no locality given (5, NDSU), Rolette County: no locality given (25, NDSU), Sheridan County: no locality given (2, NDSU), Slope County: no locality given (1, NDSU), Amidon (1, UWM), Burning Coal Vein (10, NDSU; 6, WJ), Stutsman County: no locality given (11, NDSU), Jamestown (2, USNM), Walsh County: no locality given (4, NDSU), Ward County: no locality given (95, NDSU), Wells County: no locality given

(1, NDSU), Williams County: no locality given (1, NDSU). Localities of unknown counties: La Mayce (1, NDSU). OHIO: no locality given (1, CAS; 1, INHS; 1, ISU; 1, KSU; 11, MCZ; 1, UIM; 14, USNM; 2, VPI), Ashtabula County: Ashtabula, (1, AMNH; 1, FEM; 8, MCZ; 10, USNM), Cuyahoga County: Bedford (2, AMNH), Cleveland, Rocky River Res. (7, BGSU; 2, UAF), Summit County: Hudson (2, MCZ). PENNSYLVANIA: no locality given (1, LACM), Allegheny County: Pittsburgh (4, CMP), Wilmerding (6, CMP), Cambria County: Cresson (1, CMP), Clarion County: Vowinckel (3, REA), Elk County: Portland Mills, 0.1 miles N. (6, REA), Forest County: Marienville (1, FEM), Pigeon, 1.5 miles NW. (23, REA), West Hickory Run (2, FEM), Indiana County: Indiana (9, CMP), McKean County: Klondike, 9 miles NW. (7, PSU), Marshburg, 4.5 miles NW. (25, REA), Philadelphia County: Philadelphia (1, CNC), Warren County: Cherry Grove, 5 miles W. (28, REA), Westmoreland County: Jeannette (17, CMP). Localities of unknown counties: Colmanville (7, USNM), Scandia (2, SUNY). RHODE ISLAND: no locality given (1, LACM; 3, MCZ; 1, SMEK; 1, UMAA). SOUTH DAKOTA: Caddington County: no locality given (5, NDSU), Clark County: no locality given (19, NDSU), Corson County: no locality given (4, NDSU), Custer County: Custer (2, CAS; 1, CDAS), Hand County: no locality given (1, NDSU), Hughes County: Pierre, 15 miles SE. (1, WJ), Lawrence County: Lead (1, AMNH), Spearfish Canyon, Black Hills (2, USNM; 1, WJ), Minnehaha County: Sioux Falls (1, USNM), Pennington County:

Rapid City (7, AMNH; 1, CAS; 9, USNM), Roberts County: no locality given (32, NDSU), Yankton County: Yankton (1, CMP; 28, USNM). Localities of unknown counties: Savoy, Black Hills (1, AMNH; 9, MCZ; 1, UMAA; 6, USNM). VERMONT: Bennington County: East Dorset (1, UVB), Lamoille County: Stowe (1, USNM), Stowe, Luce Hill (2, UVB), "West Elmore," Elmore State Park? (338, UVB), Washington County: no locality given (8, USNM), Crosset Brook, 7 miles SW. of Duxbury (1, UVB), Waterbury (2, UVB). Localities of unknown counties: Mount Mansfield (1, MCZ; 1, USNM), Westford (2, UVB). WISCONSIN: no locality given (4, CMP; 1, CNC; 3, INHS; 1, ISU; 3, MPM), Ashland County: Clam Lake (1, MPM), Bayfield County: Lake Namekagon (1, SMEK), Redcliffe (1, MCZ; 4, MPM), Sand Bay (1, UWM), Chippewa County: Holcombe (1, PSU), Dane County: no locality given (9, NDSU), Forest County: Eagle River (1, UWM), Nelma (4, MPM), Grant County: no locality given (2, SMEK), Iron County: Long Lake (3, MPM), Jefferson County: Palmyra, 5 miles W. (1, MPM), Sullivan, 1 mile S. (7, UGA), Kewaunee County: Kewaunee (1, AMNH), La Crosse County: La Crosse (2, CDAS), Langlade County: no locality given (2, MPM), White Lake (2, MPM), Lincoln County: Gleason (1, MPM), Milwaukee County: no locality given (1, UWM), Milwaukee (2, MPM; 2, USNM), South Milwaukee (1, MPM), Fox Point (1, MPM), Whitefish Bay (2, MPM), Oconto County: Mountain (1, MPM), Oneida County: no locality given (2, MPM), Ozaukee County: Neillsville (5,

MPM), Pierce County: Spring Valley, 3.5 miles N. (6, WJ), Racine County: Burlington, 4 miles NE. (2, DWB), Taylor County: no locality given (7, MPM; 1, PSU), Vernon County: no locality given (8, NDSU), Vilas County: Harris Lake (4, MPM; 15, USNM), Land O'Lakes (2, CU), Oxbow Lake (21, USNM), Phelps (4, MPM; 5, USNM), Presque Isle (18, USNM), Walworth County: Pleasant Lake, 7 miles E. of Elkhorn (1, MPM). Localities of unknown counties: "Apostle Island," Apostle Islands National Lakeshore? (1, MPM). WYOMING: Albany County: no locality given (2, WJ), Albany (1, MCZ), Laramie (1, SMEK), Laramie, University of Wyoming, Camp Centennial (10, AMNH; 1, USNM), Pole Mountain, Medicine Bow National Forest (4, WJ), Carbon County: Battle Creek, Medicine Bow National Forest (1, WJ), South Brush Creek Campground (5, ROM), Crook County: Alva, 6 miles E. (2, AMNH). Localities of unknown counties: Battle Lake Road, Sierra Madre Range (1, CNC), Pole Mountain Verdalwood Camp (1, AMNH).

Doubtful or Unusable Records

ARKANSAS: Perry County: Aplin (1, CAS). DISTRICT OF COLUMBIA: Washington (1, SUNY). FLORIDA: no locality given (1, CAS), Orange County: Orlando (1, AMNH). Localities of unknown counties: St. Nicholas (2, USNM). GEORGIA: Rabun County: Clayton (1, MCZ). MARYLAND: no locality given (1, USNM). NORTH CAROLINA: no locality given (1, AMNH), Buncombe County: Asheville (1, LACM). Localities of unknown counties:

Highlands (1, CUSC). OKLAHOMA: Delaware County: no locality given (1, BM). SOUTH CAROLINA: Oconee County: no locality given (1, CUSC), Pickens County: Rocky Bottom (4, CUSC). UTAH: Grand County: La Sal Mountains (1, FMNH), Iron County: Cedar City, 7 km E. (1, LU). VIRGINIA: Alexan County: no locality given (1, USNM), Montgomery County: Blacksburg (1, USNM). Localities of unknown counties: Skyland (1, USNM). WASHINGTON: Pierce County: Mount Rainier National Park (1, ROM), Whitman County: Pullman (1, USNM), Yakima County: Snowplow Mountain, W. (1, ROM). WEST VIRGINIA: West Sulphur (1, USNM). Localities of unknown regions: Butler's Landing, Buchanan (2, USNM), Calumet (1, LEM), "Dac.", Dakota? (1, CMP; 1, UMSP), East Marion Lake (1, CU), Hancock (1, LACM), Lake Bluff (3, INHS), "La.Mo.", Louisiana?, Missouri? (1, CAS), "O.", Ohio?, Oklahoma?, Oregon? (1, MCZ; 1, USNM), Orono (1, MCZ), Yaphash (1, INHS). No localities given: (1, CAS; 1, FMNH; 8, INHS; 3, LEM; 22, MCZ; 1, UAE; 4, UGO; 1, UMAA; 5, UMSP; 8, UNL; 5, USNM; 1, UWM; 1, VPI).

Records from Literature Cited

Boyd and Associates (1982) also list Indiana and Kentucky in the distribution of *C. limbalis*, and Indiana in the distribution of *C. limbalis transversa*. Since I have not seen any specimens from the aforementioned states, they are not included in the distribution map (Fig. 74).

The species *Cicindela denverensis* Casey

United States. ARKANSAS: Hempstead County: Hope (2, LACM), Lawrence County: Imboden (1, LACM). COLORADO: no locality given (12, AMNH; 14, CAS; 1, FMNH; 1, LACM; 2, MCZ; 1, UAE; 2, USNM), Boulder County: Boulder (1, CAS; 1, KSU; 8, MCZ), Cheyenne County: Cheyenne Wells (1, UMAA), Denver County: Denver (4, AMNH; 3, CAS; 2, CNC; 2, CSU; 12, LACM; 44, MCZ; 10, UMAA; 22, USNM), Oslar, Denver (7, AMNH), Douglas County: Sedalia (1, USNM), El Paso County: Colorado Springs (1, CNC; 3, MCZ; 6, UMAA; 7, USNM), Larimer County: Estes Park (2, AMNH; 2, USNM), Morgan County: Brush (1, AMNH), Fort Morgan (4, LACM; 2, MCZ; 1, NDSU), Wiggins (4, AMNH; 1, CNC; 1, USNM), Otero County: Manzanola (2, CSU; 1, NCSR), Pueblo County: Pueblo (1, MCZ), Weld County: Greeley (2, CSU; 1, PSU), Hudson (1, CNC), Yuma County: no locality given (1, LACM), Wray (1, AMNH; 1, FMNH). Localities of unknown counties: Bear Creek, Morrison (2, UMAA), Chimney Gulch (1, FMNH; 4, MCZ; 7, UMAA; 3, USNM), Clear Creek (4, MCZ; 5, UMAA), Eaton Hill, R. Mtn. Nat'l Park (1, CAS), Ford (2, CSU), Greasewood, Oil Dist. (1, AMNH; 1, CAS; 1, SMEK), Higbee (1, UMAA), Oslar (8, AMNH; 5, CNC), Platte Cam (1, MCZ; 1, SMEK; 2, UMAA; 1, USNM), Regnier (2, AMNH), Roggan (1, AMNH). KANSAS: no locality given (1, AMNH; 1, MCZ), Clark County: no locality given (2, SMEK; 1, USNM), Finney County: Garden City (1, MCZ; 1, USNM), Hamilton County: no locality given (1, SMEK), Logan County: Oakley (1, AMNH),

Meade County: no locality given (2, KSU), Meade (2, MCZ),
 Riley County: Manhattan (1, USNM). Localities of unknown
 counties: Austin (1, LACM). **KENTUCKY:** Ballard County:
 Barlow (1, LACM). **LOUISIANA:** no locality given (1, MCZ),
 Natchitoches County: Vowells Mill (1, LACM). **MONTANA:**
 Custer County: no locality given (11, NDSU), Dawson County:
 no locality given (3, MSUB), Makoshika Park, Glendive (2,
 NDSU), Gallatin County: no locality given (1, MSUB), McCone
 County: no locality given (1, NDSU), Powder River County:
 Powderville (2, MSUB), Prairie County: no locality given
 (15, NDSU; 6, PSU), Roosevelt County: no locality given (43,
 NDSU), Stillwater County: Park City (2, MSUB). **NEBRASKA:** no
 locality given (1, AMNH), Banner County: no locality given
 (1, LACM; 3, PSU), Box Butte County: Alliance (1, LACM),
 Buffalo County: Kearney (1, AMNH), Custer County: Broken
 Bow (5, MCZ; 7, UNL), Dakota County: Sioux City (1, UMSP; 1,
 USNM), Dundy County: Benkelman (1, AMNH; 5, CAS; 1, CNC; 12,
 KSU; 3, MCZ; 3, UMAA; 3, USNM), Haigler (1, AMNH; 1, CAS; 1,
 KSU), Sioux County: Hat Creek Valley (1, MCZ), Monroe Canyon
 (1, AMNH; 1, MCZ; 2, UMAA; 4, UNL), Pine Ridge (1, UNL), War
 Bonnett Canyon (4, AMNH), Scotts Bluff County: Gering, 0.7
 miles S., 8 miles W. (1, WJ). **NEW MEXICO:** no locality given
 (1, MCZ), Colfax County: Maxwell (2, USNM). **NORTH DAKOTA:**
 Adams County: Hettinger (1, WJ), Billings County: no
 locality given (2, NDSU), Bowman County: no locality given
 (2, NDSU), Corson County: no locality given (4, NDSU),

Divide County: no locality given (2, NDSU), Dunn County: no locality given (38, NDSU), Grant County: no locality given (11, NDSU), Hettinger County: no locality given (1, NDSU), McKenzie County: no locality given (86, NDSU), Mercer County: no locality given (3, NDSU), Stanton (3, NDSU), Mountrail County: no locality given (30, NDSU), Slope County: no locality given (1, NDSU), Burning Coal Vein (1, NDSU; 4, WJ), Stark County: no locality given (1, NDSU), Sully County: no locality given (2, NDSU), Ward County: no locality given (5, NDSU), Williams County: no locality given (4, NDSU). OKLAHOMA: Latimer County: Wilburton (1, LACM), Pawnee County: no locality given (1, LACM), Pawnee (1, LACM), Tulsa County: Turley (1, USNM). SOUTH DAKOTA: Hughes County: Pierre (3, AMNH), Pierre, 15 miles SE. (32, WJ), Shannon County: Hot Springs (1, MCZ). TEXAS: no locality given (1, LACM; 3, USNM), Erath County: no locality given (1, PSU), Roberts County: Miami (7, CAS). Localities of unknown counties: Forestburg (1, AMNH). WYOMING: Platte County: no locality given (1, NDSU), Glendo (1, USNM; 3, WJ).

Doubtful or Unusable Records

Canada: Alberta: Medicine Hat (1, CNC), British Columbia: Mts. between Hope and Okanagan (6, MCZ), Okanagan Falls (1, CAS). No localities given: (3, LU; 5, UNL).

Fig. 74. Distribution of *C. limbalis* (●), *C. splendida* (□) and *C. denverensis* (○).

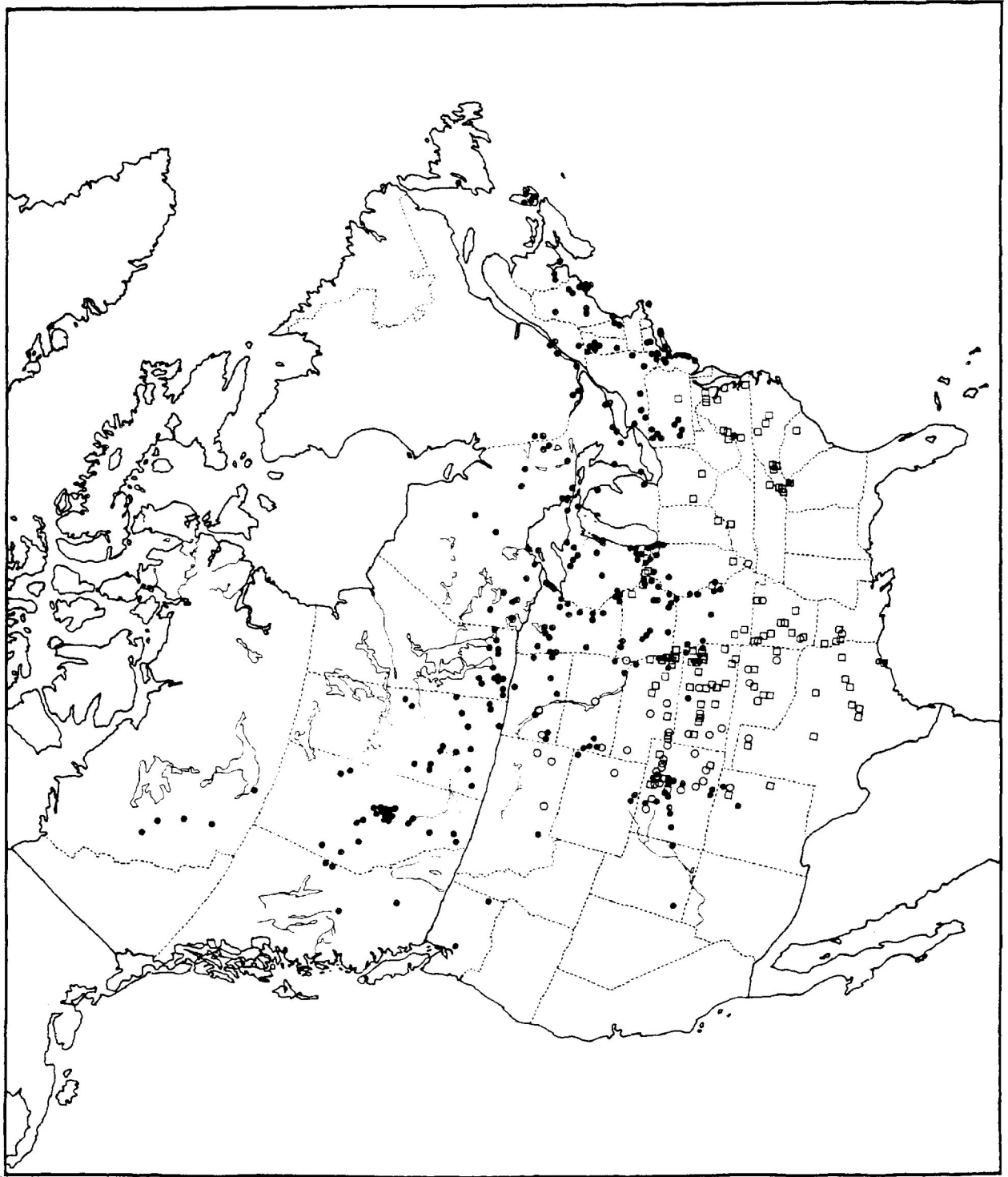

Evolution and Zoogeography

The purpose of this section is to examine phylogenetic relationships among members of the *C. splendida* group and to present its probable evolution, based on a reconstructed phylogeny, distribution and ecological data, habitat preferences and past geologic and climatic influences.

Rivalier (1954) grouped the following species of *Cicindela* in Group VII, referred to as the Formosa group: *C. formosa*, *C. purpurea*, *C. limbalis*, *C. sexguttata* Fabricius and *C. patruela* Dejean. The group was based on genitalic characters, particularly a long slender flagellum and absence of a median tooth. Rumpff (1980), after examining the genitalia indicated that a median tooth was present in males of these species except for *C. formosa* and *C. patruela*; therefore, these two species should remain in the Formosa group with the remaining species becoming the Purpurea group.

Rumpff (1980) used genitalic features to determine phylogenetic relationships among species of the Formosa and Purpurea groups. He proposed a reconstructed phylogeny for the Formosa group in which a progenitor led to *C. patruela* and *C. formosa*. He also proposed a reconstructed phylogeny for the Purpurea group in which a progenitor led to two main lineages: (1) *C. sexguttata* and *C. purpurea*; and (2) *C. plutonica* Casey and *C. decemnotata* Say. He stated that *C. splendida* and *C. limbalis* were conspecific but that *C.*

denverensis was distinct. *Cicindela plutonica* was theorized as sister group of *C. splendida* and *C. denverensis*.

The principles and methods used in phylogenetic reconstruction applied here have been discussed by Hennig (1966), Ross (1974), Eldredge and Cracraft (1980), Watrous and Wheeler (1981), Wiley (1981), Charig (1982) and Patterson (1982), among others. The procedure involves the identification of the sister group of the taxon to be analysed. The shared character states are assumed to have been inherited from a common ancestor and are designated as plesiomorphic (primitive or ancestral). The apomorphic (derived) character states are then used as evidence of phylogenetic affinity, or relative recency of common ancestry, between the species, or taxa sharing such character states. In this study I have used the *Purpurea* group as the outgroup, and general trends in the evolution of tiger beetles, for purposes of character polarization.

Although final body colour in tiger beetles is affected by temperature and moisture, the green body colour of *C. purpurea*, its near relatives and *C. denverensis*, is very common and is considered plesiomorphic, whereas the red-brown colour of *C. limbalis* and the red colour of *C. splendida* is considered apomorphic. Also, the slightly shorter flagellum of *C. denverensis* is considered plesiomorphic as compared to the slightly longer flagellum of *C. limbalis* and *C. splendida*. Furthermore, the numerical

analyses of morphometric data for the three species indicated that *C. limbalis* and *C. splendida* were more similar to each other than either of them was to *C. denverensis*. Thus, *C. denverensis* was probably the first derivative species of this group, whereas *C. splendida* and *C. limbalis* represent a more recent speciation (Fig. 75).

The lack of fossil records for members of the *C. splendida* group makes it difficult to determine its time of origin. Matthews (1979) has suggested that many of the existing Canadian insect species had probably evolved by the start of the Pleistocene; and that studies of Tertiary and Quaternary fossil insects in the north show that the evolutionary pulse of northern species was not linked to a sequential development of Pleistocene refugia. He believed the roots of both the present boreal and arctic insect faunas were well established by the Miocene, although it was climatic fluctuations of the Quaternary that were responsible for the communities and distributional patterns observed today. Morgan and Morgan (1980) and Morgan (1987) agree that there appears to have been little or no speciation in the order Coleoptera during the Pleistocene. The geographical distributional pattern of the *C. splendida* group, however, suggests that existing taxa became disjunct during the Pleistocene and possibly became species within that period.

Nagano et al. (1982) suggested that during the glaciation of North America the ice merely forced many

cicindelid populations southward at the time of maximum advance and that they remained there to successfully recolonise sandy terrain after ice retreat. Morgan and Freitag (1982) in reporting the find of fossil remains of *C. limbalis* stated that this species survived south of the ice front during maximum advance of Laurentide ice, probably in the southern parts of the region from New York to Indiana and that it was colonising open ground following the retreat of the ice.

Scudder (1979) observed that there were a number of glacial refugia for insects in North America during the last glaciation and hence a number of centres from which dispersal has taken place. Ball (1963) has suggested that refugia for ground beetles must have existed: (1) in Beringia; (2) in the Mackenzie District of arctic Canada; (3) in eastern North America; and (4) south of the glacial front. Of these it is possible that the ancestral stock of the *C. splendida* group occupied the eastern North American refugium which was principally grassland biome and the refugium south of the glacial front which was principally boreal forest biome. Howden (1969) stated that many of the cold-adapted insects survived in montane regions to the south and moved northward following the glaciers. The southern Appalachian region (Appalachian Mountains and Cumberland Plateau) and the Ozark Plateau were also important refugia for insects (Ross, 1965; Ross and Yamamoto, 1967; Ross et al., 1967). Ross (1970)

placed the prairie grassland biome during the Wisconsinan maxima on the Texas-Mexico border. Adams (1902) stated that there were three primary routes of dispersal from refugia in the southeastern United States: up the Mississippi Valley and its tributaries, along the coastal plains, and via the Appalachian Mountains and adjacent plateaus. I propose that *C. limbalis* followed the eastern dispersal routes and spread across Canada from east to west. This would explain its widespread range from the Maritimes to the Plains. The Rocky Mountains may represent a geographical barrier to further westward dispersal of these beetles.

Early lineages of the *C. splendida* group probably evolved during the later stages of the Tertiary Period, approximately 2.5 million years before present. Extant forms speciated during the late Pleistocene Epoch as a result of isolation and adaptation during glacial and interglacial periods. The historical events which may have effected geographical isolation and subsequent speciation of populations are considered to have occurred as follows.

The ancestor of this species group probably evolved as a North American resident, having no apparent European or Asiatic relative. The ancestral form was a continental, riparian, cool-temperate form that ranged across Canada and the northeastern and central United States (Fig. 76). It may have consisted of several microgeographic races living in grasslands of the Central Great Plains in the central United States. During the first glaciation, the ancestral form

occupying the northern limits of its range was pushed southward beyond the Great Lakes Region into the central United States. As a result of this first glaciation, a portion of the ancestral group became isolated in the upper elevations of the Black Hills and eastern portions of the Rocky Mountains. During the first interglacial this isolated group achieved genetic integrity and gave rise to the form *C. denverensis* (Fig. 77). The remaining portion of the ancestral group once again spread into the eastern regions of North America following the ice retreat. During the second glaciation, this ancestral form was pushed southward and eastward. Upon retreat of the ice a portion of this group became isolated in the southeast United States in the foothills of the Appalachian Mountains. These isolated populations in the south diverged genetically, and gave rise to the form *C. splendida* (Fig. 78). This form spread westward across the Mississippi Valley from the Appalachian region. The remaining portion of the ancestral group returned northward following the ice retreat and spread across Canada from east to west forming the species *C. limbalis* (Fig. 79). The apparent absence of *C. limbalis* in British Columbia may be due to extinction by the Cordilleran ice sheet which formed between the Coast Mountains and the Rocky Mountains and covered most of the lower Interior Plateau. At its maximum this ice sheet covered the mountains and plateau of the Cordillera and also extended eastward down to the Interior Plains and westward into the Pacific Ocean.

The few specimens of *C. limbalis* from British Columbia were taken from areas in the Interior Plateau and the Fraser Basin. These probably represent relict populations which somehow survived the Cordilleran glaciation.

The present geographic range of the species illustrates a mushroom shaped distribution for each, that is, a much wider range near their northern limits. This indicates that the ancestral group was a cool-temperate form that lived in a boreal forest region, and that *C. limbalis* which presently ranges across most of Canada and occupies the Great Plains of the United States was a derivative form which became cold-adapted and spread northerly. The form *C. denverensis* evolved as an inhabitant of open forest and grasslands of higher elevations. The form *C. splendida* changed greatly during its evolution, and became a grassland form adapted to a warm temperate climate.

In Canada *C. limbalis* is principally a resident of the Central Boreal Uplands of the Canadian Shield and the Southern Boreal Plains and Plateaux of the Interior Plains. In the United States *C. limbalis* occupies the Central Great Plains and the Northeastern Uplands (see Danks, 1979 and Ross, 1965 for physiographic regions of Canada and the south-central United States, respectively). The southern distribution of *C. limbalis* in the central United States corresponds to the southern limits of the glacial ice sheets.

The re-colonization of glaciated areas by *C. limbalis* has undoubtedly been affected by the type of soils

and glacial deposits present after the retreat of glacial ice. Other factors which probably limit the distribution of *C. limbalis* are biological factors such as its physiological adaptations to a temperate climate. A visual comparison of the species distribution map with The National Atlas of Canada permafrost map (EMR, 1974), revealed that most specimen localities were south of the southern limit of permafrost and that only a few specimen localities occurred in regions of scattered permafrost and very few occurred in regions of widespread permafrost. No specimen localities are recorded from areas of continuous permafrost which occurs in the Northwest Territories and the widespread mountain ranges within British Columbia.

Other factors such as reduced growing season for larvae may limit the northern distribution of this species. The southern limiting factor is probably a physiological intolerance to prolonged periods of extremely hot and dry conditions.

Recommendations for Additional Research

Questions requiring additional research have resulted from this study. I suggest the following topics.

Additional study of the copulating phases and mating behaviour among the *C. splendida* group should be performed. Virgin female beetles must be mated with males of other "species" to determine the acceptance or rejection of the initial spermatophore. It will be necessary to rear

larvae to obtain virgin females for these experiments.

Detailed information concerning field observations of interspecific mating behaviour is required for comparison with laboratory studies.

Research in the reproductive biology of this group might include: (1) histological studies involving serial sectioning of the spermatophore to map the structure; (2) verification that spermatophores become smaller with repeated insemination possibly due to limited availability of material and to determine if the later spermatophores contain sperm; (3) freezing of interspecific mating pairs during the latter part of Phase 2 of copulation to determine if the internal sac does evert and the position of insertion in the bursa copulatrix; and (4) examination of male genitalia for the presence of a spermatophore at the onset of copulation.

Experimentation involving larval rearing is required to determine the degree of variation attributable to environmental, especially edaphic, influences on body colour and elytral maculations.

Information on the life cycle as well as descriptions of egg, larval and pupal stages are required for *C. splendida* and *C. denverensis*.

Information concerning microgeographic differences in distribution, patterns of variation and habitat affinities is required in areas of sympatry and areas of hybridization. Additional insight into the phylogenetic relationships among these species might be gained by molecular techniques.

Fig. 75. Phylogeny of the *C. splendida* group.

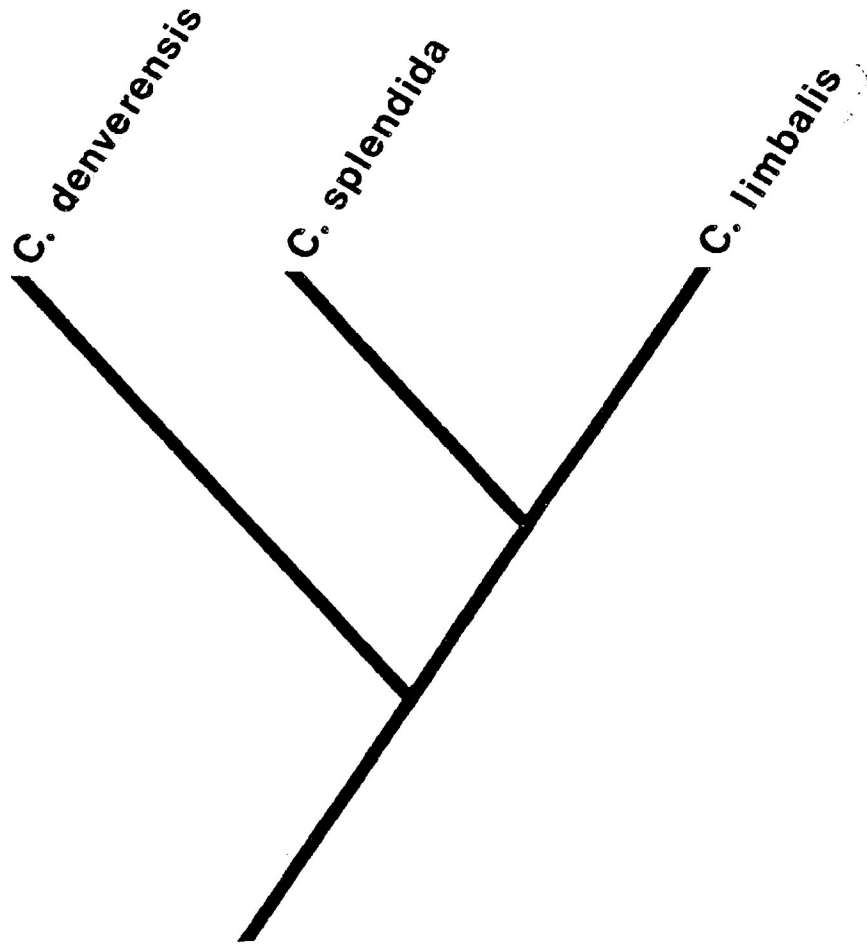

hypothetical
ancestor

- Fig. 76. Distribution of the ancestral form of the *C. splendida* group.
- Fig. 77. The position of the maximum late Wisconsinan ice mass and the distribution of the ancestral form with a portion becoming *C. denverensis* (O).
- Fig. 78. The position of the retreating ice mass, the isolated population of *C. denverensis* (O), and the distribution of the ancestral form with a portion becoming *C. splendida* (□).
- Fig. 79. The position of the retreating ice mass and the distribution of *C. denverensis* (O), *C. splendida* (□), and the most recent form, *C. limbalis* (●).

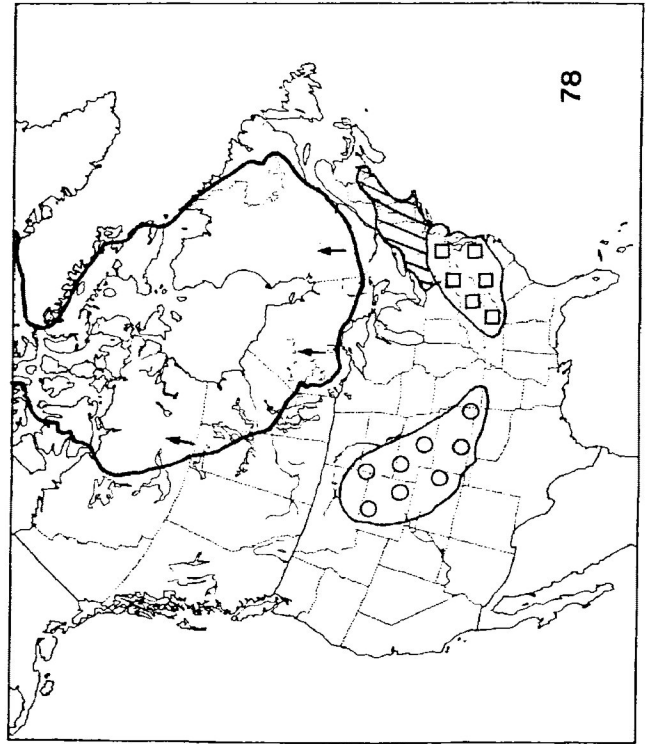
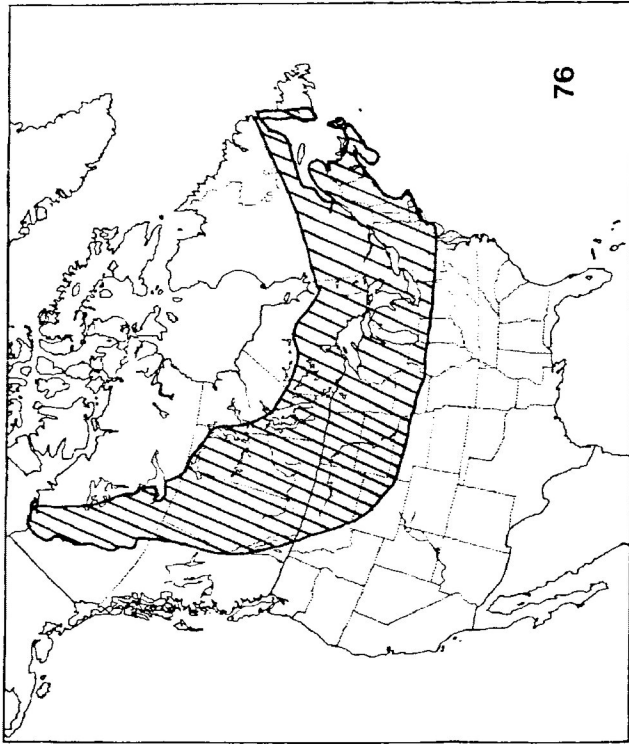
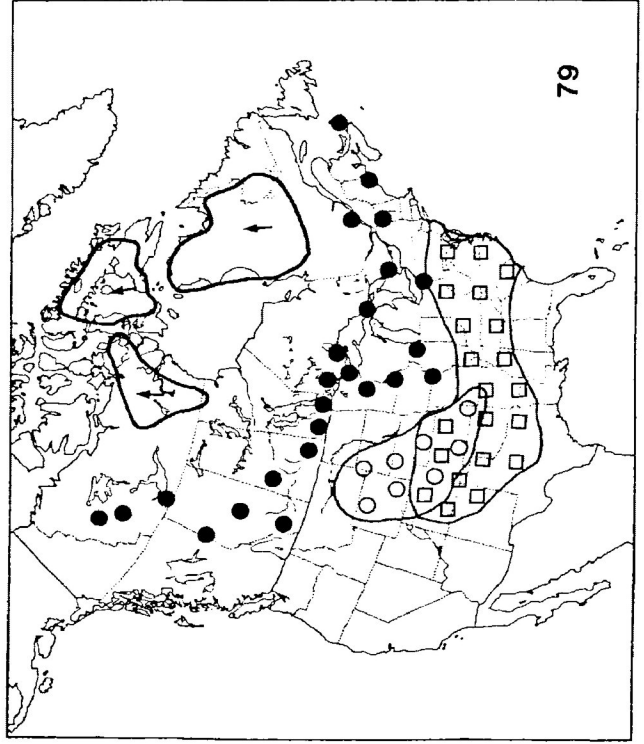
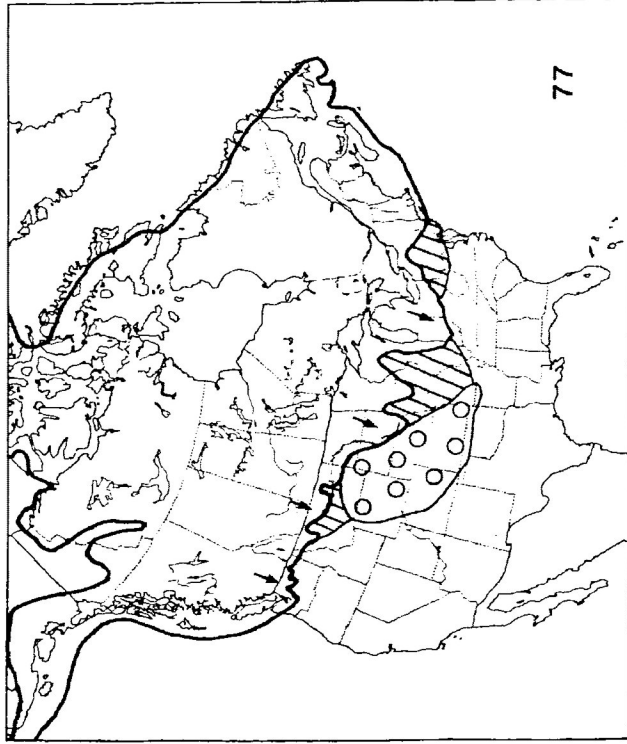

LITERATURE CITED

- Acciavatti, R.E. 1979. Checklist of New Mexico *Cicindela* with regional distributions. *Cicindela* 11(2):27-32.
- Adams, C.C. 1902. Southeastern United States as a center of geographical distribution of flora and fauna. *Biol. Bull.* 3(3):115-131.
- Armson, K.A. 1977. Forest soils: properties and processes. University of Toronto Press, Toronto and Buffalo. xii + 390 pp.
- Baccetti, B. 1970. Comparative spermatology. Academic Press, Inc., New York, New York. 573 pp.
- Baccetti, B. 1972. Insect sperm cells. *Advances in Insect Physiology* 9:315-397.
- Baccetti, B. and B.A. Afzelius. 1976. The biology of the sperm cell. S. Karger, Basel, Switzerland. vi + 254 pp.
- Ball, G.E. 1963. The distribution of the species of the subgenus *Cryobius* (Coleoptera, Carabidae, *Pterostichus*) with special reference to the Bering land bridge and Pleistocene refugia, pp. 133-151 In J.L. Gressitt (Ed.), Pacific Basin biogeography. Bishop Museum Press, Honolulu, Hawaii. ix + 563 pp.
- Beatty, R.A. 1975. Sperm diversity within the species, pp. 319-327 In B.A. Afzelius, The functional anatomy of the spermatozoon. Pergamon Press Ltd., Oxford. 393 pp.
- Beatty, D.R. and C.B. Knisley. 1982. A description of the larval stages of *Cicindela rufiventris* Dejean (Coleoptera: Cicindelidae). *Cicindela* 14(1-4):1-17.
- Blackwelder, R.E. 1939. Fourth Supplement to The Leng Catalogue of Coleoptera of America, north of Mexico. John D. Sherman, Jr., Mount Vernon, New York. 146 pp.
- Blatchley, W.S. 1910. An illustrated descriptive catalogue of the Coleoptera or beetles (exclusive of the Rhynchophora) known to occur in Indiana. *Bull. No. 1, Ind. Dept. Geol. Nat. Res.*, 1386 pp., 590 figs.
- Blisson, J.F.J. 1848. Note pour servir à compléter l'histoire des moeurs et des métamorphoses de la *Cicindela*

- campestris*. Ann. Soc. Ent. Fr., sér. 2. 6:155-165.
- Boyd, H.P. 1978. The tiger beetles (Coleoptera: Cicindelidae) of New Jersey with special reference to their ecological relationships. Trans. Amer. Ent. Soc. 104:191-242.
- Boyd, H.P. and Associates. 1982. Checklist of Cicindelidae: The tiger beetles. Plexus Publishing, Inc., Marlton, New Jersey. 31 pp.
- Cartwright, O.L. 1935. The tiger beetles of South Carolina with the description of a new variety of *Tetracha virginica* (L.) (Coleoptera: Cicindelidae). Bull. Brooklyn Ent. Soc. 30:69-77.
- Casey, T.L. 1897. Coleopterological Notices. VII. Ann. N.Y. Ac. Sci. 9:285-684.
- Casey, T.L. 1913. Studies in the Cicindelidae and Carabidae of America. Mem. of the Coleop. IV, Lancaster. 4:1-193.
- Casey, T.L. 1914a. I--Studies in *Omus* and *Cicindela*. Mem. of the Coleop. V, Lancaster. 5:1-24.
- Casey, T.L. 1914b. Miscellaneous notes and new species. Mem. on the Coleop. V, Lancaster. 5:355-378.
- Cazier, M.A. 1936. Review of the *willistoni*, *fulgida*, *parowana*, and *senilis* groups of the genus *Cicindela* (Coleoptera: Cicindelidae). Bull. S. Calif. Acad. Sci. 35(3):156-163.
- Cazier, M.A. 1948. The origin, distribution, and classification of the tiger beetles of lower California (Coleoptera: Cicindelidae). Amer. Mus. Novit. 1382, 28 pp.
- Chapman, R.F. 1982. The insects: structure and function, 3rd ed. Harvard University Press, Cambridge, Massachusetts. xiv + 919 pp.
- Charig, A. 1982. Cladistics: A different point of view, pp. 121-124 In J.M. Smith (Ed.), Evolution now: A century after Darwin. W.H. Freeman and Company, San Francisco. 239 pp.
- Clayton, J.S., W.A. Ehrlich, D.B. Cann, J.H. Day, and I.B. Marshall. 1977. Soils of Canada. Vol. I. Soil Report, Vol. II. Soil Inventory. Agriculture Canada, Ottawa. 243 pp. and 239 pp.

- Cohen, J. 1975. Gametic diversity within an ejaculate, pp. 329-339 In B.A. Afzelius, The functional anatomy of the spermatozoon. Pergamon Press Ltd., Oxford. 393 pp.
- Criddle, N. 1907. Habits of some Manitoba "Tiger Beetles" (*Cicindela*). Can. Ent. 39(4):105-114.
- Criddle, N. 1910. Habits of some Manitoba tiger beetles (*Cicindelidae*). No. 2. Can. Ent. 42:9-15.
- Criddle, N. 1919. Fragments in the life-habits of Manitoba insects. Can. Ent. 51(5):97-101.
- Cutler, B. 1969a. An unusual series of *Cicindela limbalis* from South Dakota. *Cicindela* 1(2):5-7.
- Cutler, B. 1969b. Of early birds and worms. *Cicindela* 1(2):14.
- Danks, H.V. (Ed.). 1979. Canada and its insect fauna. Mem. ent. Soc. Can. 108. 573 pp.
- Davey, K.G. 1965. Reproduction in the insects. W.H. Freeman and Company, San Francisco. x + 96 pp.
- Davis, C.A. 1903. The *Cicindelidae* of Rhode Island. Ent. News. 14:270-273.
- Dawes, C.J. 1971. Biological techniques in electron microscopy. Barnes & Noble, Inc., New York. xiv + 193 pp.
- Dawson, R.W. and W. Horn. 1928. The tiger beetles of Minnesota. Minn. Tech. Bull. 56:1-13.
- Drew, W.A. and H.W. Van Cleave. 1961. The tiger beetles of Oklahoma (*Cicindelidae*). Proc. Okla. Acad. Sci. 42:101-122.
- Dunn, G.A. 1978. Tiger beetles of New Hampshire (Coleoptera: *Cicindelidae*). Unpublished M.S. Thesis, University of New Hampshire. x + 161 pp.
- Dunn, G.A. 1981. Tiger beetles of New Hampshire. *Cicindela* 13(1/2):1-28.
- Durrant, S.D. 1955. In defense of the subspecies. Syst. Zool. 4(4):186-190.
- Eberhard, W.G. 1985. Sexual selection and animal genitalia. Harvard University Press, Cambridge, Massachusetts.

244 pp.

- Eckhoff, D.E. 1939. The Cicindelidae of Iowa (Coleoptera).
Iowa State Coll. J. Sci. 13:201-230.
- Eckhoff, D.E. 1970. A new name for *Cicindela cyanocephalata*
Eckhoff. Coleop. Bull. 24(1):32.
- Edwards, J.G. 1954. A new approach to infraspecific
categories. Syst. Zool. 3(1):1-20.
- Eldredge, N. and J. Cracraft. 1980. Phylogenetic patterns and
the evolutionary process: Method and theory in
comparative biology. Columbia University Press, New
York. vii + 349 pp.
- EMR. 1974. The National Atlas of Canada. 4th ed. (Revised).
The Macmillan Company of Canada Limited, Toronto,
Ontario, in association with the Department of
Energy, Mines and Resources and Information Canada,
Ottawa, Ontario, Canada. 254 pp.
- Enock, F. 1903. The life history of *Cicindela campestris*.
Proc. Ent. Soc. Lond., 1903, 15-19.
- Fackler, H.L. 1918. The tiger beetles of Kansas (Family
Carabidae: subfamily Cicindelinae) Order
Coleoptera. Unpublished Masters Thesis, University
of Kansas. 51 pp., 5 pls.
- Ferris, C.D. 1969. Notes on collecting early *Cicindela* in
eastern Wyoming. *Cicindela* 1(2):9-12.
- FitzPatrick, E.A. 1980. Soils: Their formation,
classification and distribution. Longman Inc., New
York. xix + 353 pp.
- Fléchon, J.E., Bergström, S., Jaszczak, S. and E.S.E. Hafez.
1975. Techniques for critical point drying of
gametes and embryos. Scanning Electron Microscopy
IITRI 1:325-332.
- Fox, W.J. 1902. Doings of Societies. Ent. News 13(6):198-199.
- Freitag, R. 1965. A revision of the North American species of
the *Cicindela maritima* group with a study of
hybridization between *Cicindela duodecimguttata* and
oregona. Quaest. Ent. 1:87-170.
- Freitag, R. 1966. The female genitalia of four species of
tiger beetles (Coleoptera: Cicindelidae). Can.
Ent. 98:942-952.

- Freitag, R. 1972. Female genitalia of the North American species of the *Cicindela maritima* group (Coleoptera: Cicindelidae). Can. Entomol. 104:1277-1306.
- Freitag, R. 1974. Selection for a non-genitalic mating structure in female tiger beetles of the genus *Cicindela* (Coleoptera: Cicindelidae). Can. Ent. 106(6):561-568.
- Freitag, R. 1979. Reclassification, phylogeny and zoogeography of the Australian species of *Cicindela* (Coleoptera: Cicindelidae). Aust. J. Zool. Suppl. Ser. 66:1-99.
- Freitag, R., Olynyk, J.E. and B.L. Barnes. 1980. Mating behavior and genitalic counterparts in tiger beetles (Carabidae: Cicindelinae). Int. J. Invertebr. Reprod. 2:131-135.
- Freitag, R. and R. Tropea. 1969. Twenty-one Cicindelid species in thirty-eight days. *Cicindela* 1(4):14-23.
- Freitag, R., Schincariol, L.A. and B.L. Barnes. 1985. A review of nomenclature for genitalic structures of *Cicindela*. *Cicindela* 17(2):17-27.
- Frost, C.A. 1920. Notes on the Coleoptera with descriptions of new species. Can. Ent. 52:129-232, 249-252.
- Gaumer, G.C. 1969. Coastal tiger beetles of Texas in the genus *Cicindela* (Coleoptera: Cicindelidae). *Cicindela* 1(1):2-16.
- Gaumer, G.C. 1977. The variation and taxonomy of *Cicindela formosa* Say (Coleoptera: Cicindelidae). Unpublished Ph.D. Dissertation, Texas A&M University. 253 pp.
- Gaumer, G.C. and R.R. Murray. 1971. Checklist of the Cicindelidae of Texas with regional distributions. *Cicindela* 3(1):9-12.
- Geoffroy, E.L. 1762. Histoire abrégée des insectes qui se trouvent aux environs de Paris. Paris, 1762, 1:139.
- Gosline, W.A. 1954. Further thoughts on subspecies and trinomials. Syst. Zool. 3(2):92-94.
- Graves, R.C. 1963. The Cicindelidae of Michigan (Coleoptera). The American Midland Naturalist 69(2):492-507.

- Graves, R.C. 1965. The distribution of tiger beetles in Ontario (Coleoptera: Cicindelidae). Proc. Ent. Soc. Ont. 95:63-70.
- Graves, R.C. 1969. Victor E. Shelford's contributions to the study of the Cicindelidae. *Cicindela* 1(4):11-13.
- Graves, R.C. 1987. Five new subspecies of the North American tiger beetle *Cicindela hirticollis* Say (Coleoptera: Cicindelidae). (Unpublished manuscript). 24 pp., 5 figs., 1 table.
- Graves, R.C. and D.L. Pearson. 1973. The tiger beetles of Arkansas, Louisiana, and Mississippi (Coleoptera: Cicindelidae). Trans. Amer. Ent. Soc. 99:157-203.
- Graves, R.C., Krejci, M.E. and A.C.F. Graves. 1987. Geographic variation and subspeciation in the Nearctic tiger beetle, *Cicindela hirticollis* (Coleoptera: Cicindelidae). (Unpublished manuscript). 44 pp., 33 figs., 1 table.
- Green, R.H. 1979. Sampling design and statistical methods for environmental biologists. John Wiley & Sons, Inc., USA. xiii + 257 pp.
- Greene, G.M. 1914. Doings of Societies. Ent. News 25(5):237-239.
- Haimbach, F. 1908. Doings of Societies. Ent. News 19(7):343-344.
- Hamilton, C.C. 1925. Studies on the morphology, taxonomy, and ecology of the larvae of holarctic tiger beetles (family Cicindelidae). Proc. U.S. National Museum 65:1-87.
- Harris, E.D. 1911. List of North American Cicindelidae in the Harris Collection. Traun Press, Yonkers, New York. 68 pp.
- Harris, E.D. and C.W. Leng. 1916. The Cicindelinae of North America as arranged by Dr. Walther Horn in Genera Insectorum. Amer. Mus. Nat. Hist. 23 pp.
- Harris, R.J. 1975. A primer of multivariate statistics. Academic Press, Inc., New York, New York. xiv + 332 pp.
- Hennig, W. 1966. Phylogenetic systematics. University of Illinois Press, Urbana, Illinois. 263 pp.

- Hentz, N.M. 1830. Description of eleven new species of North American insects. Trans. Am. Phil. Soc. 3:253-258.
- Heppner, J.B. and G. Lamas. 1982. Acronyms for world museum collections of insects, with an emphasis on Neotropical Lepidoptera. Bull. Ent. Soc. Amer. 28(3):305-315.
- Hilchie, G.J. 1985. The tiger beetles of Alberta (Coleoptera: Carabidae, Cicindelini). Quaest. Ent. 21:319-347.
- Hooper, R.R. 1969. A review of Saskatchewan tiger beetles. *Cicindela* 1(4):1-5.
- Hori, M. 1982. The biology and population dynamics of the tiger beetle, *Cicindela japonica* (Thunberg). *Physiol. Ecol. Japan* 19(2):77-212.
- Horn, G.H. 1892. Variations of color-markings in Coleoptera. *Ent. News* 3(2):25-28, pls. 1.
- Horn, W. 1908. Coleoptera. Adepaga. Family Carabidae. subfamily Cicindelinae. Wytsman Genera Insectorum. Bruxelles. fasc. 82A (1908), 82B (1910), 82C (1915). 486 pp., 23 pls.
- Horn, W. 1938. 2000 Zeichnungen von Cicindelinae. *Entomologische Beihefte* 5:1-77, pls. 90.
- Howden, H.F. 1969. Effects of the Pleistocene on North American insects. *A. Rev. Ent.* 14:39-56.
- Hubbell, T.H. 1954. The naming of geographically variant populations. *Syst. Zool.* 3(3):113-121.
- Huber, R.L. 1969a. Opera Citata, alphabetically arranged, for original descriptions of Nearctic *Cicindela* & allies. *Cicindela* 1(1):18-23.
- Huber, R.L. 1969b. Homonymy in the Nearctic *Cicindela*. *Cicindela* 1(2):19-22.
- Huie, L.H. 1915. The bionomics of the tiger beetle (*Cicindela campestris*). *Proc. Roy. Phys. Soc. Edinburgh* 20:1-11.
- Humason, G.L. 1979. Animal tissue techniques, 4th ed. W.H. Freeman and Company, San Francisco. xiii + 661 pp.
- Johnson, W.N. 1979. Sympatric population of *Cicindela limbalis transversa* and *Cicindela splendida cyanocephalata*. *Cicindela* 11(2):26.

- Johnson, W.N. 1983. Notes on *Cicindela splendida* Hentz-*limbalis* Klug-*denverensis* Casey and *ludoviciana* Leng. (Unpublished manuscript). 14 pp.
- Kaulbars, M.M. 1982. Systematics and ecology of the *sexguttata* species group, genus *Cicindela* (Coleoptera: Cicindelidae). Unpublished M.Sc. Thesis, Lakehead University. 237 pp.
- Kelly, K.L. and D.B. Judd. 1965. The ISCC-NBS method of designating colors and a dictionary of color names. National Bureau of Standards Circular 553, and Supplement to NBS Circular 553: ISCC-NBS color-name charts illustrated with centroid colors. U.S. Government Printing Office, Washington, D.C. v + 158 pp. and 18 color charts.
- Klug, J.C.F. 1834. Jarbücher der Insectenkunde mit besonderer Rücksicht auf die sammlung in Königl. Museum in Berlin herausgegeben. Berlin, 1:1-396.
- Knaus, W. 1900. The Cicindelidae of Kansas. Can. Ent. 32:109-116.
- Knaus, W. 1901. Collecting notes on Kansas Coleoptera. II. Can. Ent. 33:110-115.
- Knaus, W. 1922. Two new forms of *Cicindela* with remarks on other forms. J.N.Y. Ent. Soc. 30:194-197.
- Knisley, C.B. and D.L. Pearson. 1984. Biosystematics of larval tiger beetles of the Sulphur Springs Valley, Arizona. Descriptions of species and a review of larval characters for *Cicindela* (Coleoptera: Cicindelidae). Trans. Amer. Ent. Soc. 110:465-551.
- Kraus, B. and R.C. Lederhouse. 1983. Contact guarding during courtship in the tiger beetle *Cicindela marutha* Dow (Coleoptera: Cicindelidae). Am. Mid. Nat. 110(1):208-211.
- Ladd, M.W. 1973. The electron microscope handbook: specimen preparation and related laboratory procedures. Ladd Research Industries, Inc., Burlington, Vermont. vi + 54 pp.
- Lantz, D.E. 1905. Notes on collecting Cicindelidae. Trans. Kans. Acad. Sci. 19:252-260.
- LaRivers, I. 1946. An annotated list of the Cicindelidae known to occur in Nevada (Coleoptera). Pan.-Pac. Ent. 22(4):135-141.

- Larochelle, A. 1972a. Notes on the dates of *Cicindela* copulation in eastern Canada. *Cicindela* 4(1):8.
- Larochelle, A. 1972b. The Cicindelidae of Quebec. *Cicindela* 4(3):49-66.
- Larochelle, A. 1974a. The food of Cicindelidae of the world. *Cicindela* 6(2):21-43.
- Larochelle, A. 1974b. The northern limits of Cicindelidae in Quebec. *Cicindela* 6(4):87-88.
- Larochelle, A. 1975. Les Carabidae du Québec et du Labrador. Département de Biologie du Collège Bourget, Rigaud. Bulletin 1, 255 pp.
- Larochelle, A. 1976. Les Cicindèles du Québec. *Fabriques* 2(5):72-79.
- Larochelle, A. 1977. Notes on the food of tiger beetle larvae. *Cicindela* 9(1):13-14.
- Larochelle, A. 1978. C.W. Leng's contributions to Cicindelid entomology. *Cicindela* 10(3):33-36.
- Larochelle, A. 1979. Cicindelidae from the U.S.A. in the Canadian National Collection. *Cicindela* 11(1):13-15.
- Larochelle, A. 1980. Cicindelidae of the Maritime Provinces of Canada. *Cicindela* 12(3):35-39.
- Larson, P.R. 1981. The tiger beetles of North Dakota (Coleoptera: Cicindelidae). *Proc. North Dakota Acad. Sci.* 35:52.
- Lawton, J.K. 1970. Notes on collecting tiger beetles in the southeastern United States. *Cicindela* 2(3):1-7.
- Lawton, J.K. 1971. Collecting notes on the *Cicindela* of the Ozark Uplands, northwestern Louisiana, northeastern Texas, Oklahoma and Kansas. *Cicindela* 3(4):61-68.
- Lawton, J.K. 1972. Collecting notes on the tiger beetles in southwestern and southcentral United States-spring trip 1970. *Cicindela* 4(2):35-48.
- Lawton, J.K. 1974. An abnormal elytron of *Cicindela formosa generosa*. *Cicindela* 6(4):71-72.
- LeConte, J.L. 1848. A descriptive catalogue of the Geodephagous Coleoptera inhabiting the United

- States east of the Rocky Mountains. *Ann. Lyc. Nat. Hist. N.Y.* 4:173-474, 14 pls.
- LeConte, J.L. 1856. Revision of the Cicindelae of the United States. *Trans. Am. Phil. Soc.* 11:27-63, 1 plate.
- Leffler, S.R. 1979. Tiger beetles of the Pacific Northwest (Coleoptera: Cicindelidae). Unpublished Ph.D. Dissertation, University of Washington. 791 pp.
- Leng, C.W. 1902a. Revision of the Cicindelidae of Boreal America. *Trans. Am. Ent. Soc.* 28:93-186, 4 pls.
- Leng, C.W. 1902b. Notes on Cicindelidae of Louisiana. *J.N.Y. Ent. Soc.* 10:131-136.
- Leng, C.W. 1912. The geographical distribution of Cicindelidae in Eastern North America. *J.N.Y. Ent. Soc.* 20(1):1-17.
- Leng, C.W. 1920. Catalogue of the Coleoptera of America, north of Mexico. John D. Sherman, Jr., Mount Vernon, New York. 470 pp.
- Leng, C.W. and A.J. Mutchler. 1933. Second and Third Supplements to Catalogue of the Coleoptera of America, north of Mexico. John D. Sherman, Jr., Mount Vernon, New York. 112 pp.
- Lillie, R.D. 1965. Histopathologic technic and practical histochemistry, 3rd ed. McGraw-Hill, Inc., New York. xii + 715 pp.
- Lindroth, C.H. 1955. The Carabid beetles of Newfoundland including the French Islands of St. Pierre and Miquelon. *Opusc. Ent. Supp.* 12:1-160, 58 figs.
- Martin, J.E.H. 1978. The insects and arachnids of Canada. Part 1. Collecting, preparing and preserving insects, mites and spiders. Printing and Publishing Supply and Services Canada, Hull, Quebec, Canada. 182 pp.
- Mather, B. 1971. A preliminary report on Mississippi Cicindelidae. *Cicindela* 3(2):21-25.
- Matthews, J.V., Jr. 1979. Tertiary and Quaternary environments: historical background for an analysis of the Canadian insect fauna, pp. 31-86 In H.V. Danks (Ed.), *Canada and its insect fauna*. *Mem. ent. Soc. Can.* 108. 573 pp.

- Mayr, E. 1954. Notes on Nomenclature and Classification. Syst. Zool. 3(2):86-89.
- Mayr, E. 1969. Principles of systematic zoology. McGraw-Hill, Inc., USA. xi + 428 pp.
- Mayr, E. 1970. Populations, species, and evolution: an abridgment of animal species and evolution. The Belknap Press of Harvard University Press, Cambridge, Massachusetts. xviii + 453 pp.
- Mayr, E. 1982a. Of what use are subspecies? The Auk 99(3):593-595.
- Mayr, E. 1982b. The growth of biological thought: diversity, evolution, and inheritance. The Belknap Press of Harvard University Press, Cambridge, Massachusetts. ix + 974 pp.
- Meserve, F.G. 1936. The Cicindelidae of Nebraska (Coleoptera). Ent. News 47(10):270-275.
- Mollard, D.G. 1979a. Northern Ontario engineering geology terrain study, data base map, Kaministikwia. Ontario Geological Survey, Map 5045, Scale 1:100,000.
- Mollard, D.G. 1979b. Northern Ontario engineering geology terrain study, data base map, Thunder Bay. Ontario Geological Survey, Map 5047, Scale 1:100,000.
- Moore, R. 1906. Notes on the habits of *Cicindela*. Ent. News 17(11):338-343.
- Morgan, A.V. 1987. Late Wisconsin and early Holocene paleoenvironments of east-central North America based on assemblages of fossil Coleoptera, pp. 353-370 In W.F. Ruddiman and H.E. Wright, Jr. (Eds.), The geology of North America, Vol. K-3, North America and adjacent oceans during the last deglaciation: Boulder, Colorado, Geological Society of America.
- Morgan, A.V. and A. Morgan. 1980. Faunal assemblages and distributional shifts of Coleoptera during the late Pleistocene in Canada and the northern United States. Can. Ent. 112:1105-1128.
- Morgan, A.V. and R. Freitag. 1982. The occurrence of *Cicindela limbalis* Klug (Coleoptera: Cicindelidae) in a late-glacial site at Brampton, Ontario. Coleop. Bull. 36(1):105-108.

- Mury-Meyer, E.J. 1983. An analysis of survivorship and foraging methods in the larvae of three sympatric species of tiger beetles (Coleoptera: Cicindelidae) occurring in Central Pennsylvania. Unpublished Ph.D. Dissertation, The Pennsylvania State University. 148 pp., 72 tables, 59 figs.
- Nagano, C.D., Miller, S.E. and A.V. Morgan. 1982. Fossil tiger beetles (Coleoptera: Cicindelidae): Review and new Quaternary records. *Psyche* 89(3-4):339-346.
- Nath, V. 1965. Animal gametes (male): A morphological and cytochemical account of spermatogenesis. Asia Publishing House. xvi + 162 pp., 184 figs.
- Nath, V., Gupta, B.L. and L.C. Mittal. 1960. Position of the proximal centriole in flagellate spermatozoa. *Nature* 186(4728):899-901.
- Nath, V., Gupta, B.L. and S. Mehta. 1957. Spermatogenesis of *Cicindela* with special reference to acrosome-formation, centrosome and nuclear vesicle. *Research Bulletin of the Panjab University* 104:251-261.
- Nicolay, A.S. 1934. An answer to E. Graywood Smyth on "Synopsis of Cicindelidae" (Coleoptera). *Ent. News* 45(5):127-131.
- Nicolay, A.S. and H.B. Weiss. 1932. Synopsis of the Cicindelidae. I. General Introduction, Bibliography and Purpurea Group. *J.N.Y. Ent. Soc.* 40:341-355.
- Norusis, M.J. 1983. SPSS-X Introductory statistics guide. SPSS Inc., Chicago, Illinois and McGraw-Hill Book Company, USA. xii + 276 pp.
- Norusis, M.J. 1985. SPSS-X Advanced statistics guide. SPSS Inc., Chicago, Illinois and McGraw-Hill Book Company, USA. v + 505 pp.
- O'Brien, T.P. and M.E. McCully. 1981. The study of plant structure: principles and selected methods. Termarcarphi Pty. Ltd., Melbourne, Australia. x + 347 pp.
- Ontario Department of Lands and Forests, Map S265, Thunder Bay Surficial Geology, Scale 1:506,880 (1965).
- Owen, D.F. 1963. Variation in North American Screech Owls and the subspecies concept. *Syst. Zool.* 12(1):8-14.

- Palmer, M.K. 1976. Natural history and behavior of *Pseudoxychila tarsalis* Bates. *Cicindela* 8(4):61-92.
- Palmer, M.K. 1978. Growth rates and survivorship of tiger beetle larvae. *Cicindela* 10(4):49-66.
- Palmer, M.K. 1979. Rearing tiger beetles in the laboratory. *Cicindela* 11(1):1-11.
- Palmer, M.K. and M.A. Gorrick. 1979. Influence of food on development in tiger beetle larvae. *Cicindela* 11(2):17-25.
- Parkes, K.C. 1955. Sympatry, allopatry, and the subspecies in birds. *Syst. Zool.* 4(1):35-40.
- Parkes, K.C. 1982. Subspecific taxonomy: unfashionable does not mean irrelevant. *The Auk* 99(3):596-598.
- Patterson, C. 1982. Cladistics, pp. 110-120 In J.M. Smith (Ed.), *Evolution now: A century after Darwin*. W.H. Freeman and Company, San Francisco. 239 pp.
- Pease, D.C. 1964. *Histological techniques for electron microscopy*, 2nd ed. Academic Press, Inc., New York, New York. xv + 381 pp.
- Phillips, D.M. 1970. Insect flagellar tubule patterns. Theme and variations, pp. 263-270, figs. 6 In B. Baccetti, *Comparative Spermatology*. Academic Press, Inc., New York, New York. 573 pp.
- Pimentel, R.A. 1979. *Morphometrics: the multivariate analysis of biological data*. Kendall/Hunt Publishing Company, Dubuque, Iowa. x + 276 pp.
- Rivalier, E. 1954. Démembrement du genre *Cicindela* Linné. II. Faune Américaine. *Rev. franç. d'Ent.* 21:249-268.
- Ross, H.H. 1965. Pleistocene events and insects, pp. 583-596 In H.E. Wright, Jr. and D.G. Frey (Eds.), *The Quaternary of the United States*. Princeton University Press and The Colonial Press Inc., USA. x + 922 pp.
- Ross, H.H. 1970. The ecological history of the Great Plains: evidence from grassland insects. pp. 225-240 In W. Dort, Jr. and J.K. Jones, Jr. (Eds.), *Pleistocene and recent environments of the central Great Plains*. The University Press of Kansas, Lawrence. 433 pp.

- Ross, H.H. 1974. Biological systematics. Addison-Wesley Publishing Company, Inc., USA. 345 pp.
- Ross, H.H., Rotramel, G.L., Martin, J.E.H. and J. McAlpine. 1967. Postglacial colonization of Canada by its subboreal winter stoneflies of the genus *Allocapnia*. Can. Ent. 99:703-712.
- Ross, H.H. and T. Yamamoto. 1967. Variations in the winter stonefly *Allocapnia granulata* as indicators of Pleistocene faunal movements. Ann. ent. Soc. Am. 60:447-458.
- Rumpp, N.L. 1980. A study leading to a revision of the *Purpurea* and *Formosa* groups of the genus *Cicindela* (Cicindelidae-Coleoptera). (Unpublished manuscript). 32 pp., 8 figs.
- Rumpp, N.L. 1981. A study to determine differences between *Cicindela splendida* and *Cicindela limbalis*. (Unpublished manuscript). 10 pp.
- Rumpp, N.L. 1983. Afterthoughts on *C. denverensis*. (Unpublished manuscript). 1 p.
- Rumpp, N.L. 1984. A study of the female genitalia leading to a revision of the *Purpurea* group of the genus *Cicindela*. (Unpublished manuscript). 9 pp.
- Sakaluk, S.K. 1985. Spermatophore size and its role in the reproductive behaviour of the cricket, *Gryllodes supplicans* (Orthoptera: Gryllidae). Can. J. Zool. 63(7):1652-1656.
- Schaupp, F.G. 1883. Synoptic tables of Coleoptera. Cicindelidae. Bull. Brook. Ent. Soc. 6:73-108, 121-126, 5 pls.
- Schincariol, L.A. 1984. Genitalic counterparts of *Cicindela tranquebarica* Herbst (Coleoptera: Cicindelidae) with emphasis on the structure and function of the flagellum. H.B.Sc. Thesis, Lakehead University. 67 pp.
- Schincariol, L.A. and R. Freitag. 1986. Copulatory locus, structure and function of the flagellum of *Cicindela tranquebarica* Herbst (Coleoptera: Cicindelidae). Int. J. Invertebr. Reprod. Devel. 9:333-338.
- Schultz, T. 1982. Interspecific copulation of *Cicindela scutellaris* and *Cicindela formosa*. *Cicindela*

14(1/4):41-44.

- Scudder, G.G.E. 1979. Present patterns in the fauna and flora of Canada, pp. 87-179 In H.V. Danks (Ed.), Canada and its insect fauna. Mem. ent. Soc. Can. 108. 573 pp.
- Shelford, V.E. 1907. Preliminary note on the distribution of the tiger beetles (*Cicindela*) and its relation to plant succession. Biol. Bull. 14:9-14.
- Shelford, V.E. 1908. Life-histories and larval habits of the tiger beetles (*Cicindelidae*). Journ. Linn. Soc., Zool. 30:157-184, pls. 23-26, 58 figs.
- Shelford, V.E. 1911. Physiological animal geography. J. Morph. 22:551-618.
- Shelford, V.E. 1913a. Noteworthy variations in the elytral tracheation of *Cicindela* (Coleop.). Ent. News 24:124-125.
- Shelford, V.E. 1913b. The life-history of a bee-fly (*Spogostylum anale* Say) parasite of the larva of a tiger beetle (*Cicindela scutellaris* Say var. *Lecontei* Hald.). Ann. Ent. Soc. Amer. 6:213-225.
- Shelford, V.E. 1917. Color and color-pattern mechanism of tiger beetles. Illinois Biological Monographs 3(4):395-532.
- Sherman, F., Jr. 1904. List of the *Cicindelidae* of North Carolina, with notes on the species. Ent. News 15(1):26-32.
- Sherman, F., Jr. 1908. Notes on tiger-beetles and elevations. Ent. News 19(8):360-362.
- Simpson, G.G. 1961. Principles of animal taxonomy. Columbia University Press, New York. xii + 247 pp.
- Skinner, H. 1904. Doings of Societies. Ent. News 15(10):346-347.
- Smith, D.S. 1968. Insect cells: their structure and function. Oliver and Boyd Ltd., Edinburgh. xvii + 372 pp.
- Smith, H.M. and F.N. White. 1956. A case for the trinomen. Syst. Zool. 5(4):183-190.
- Smyth, E.G. 1907. Notes on collecting *Cicindelidae*. II.

- Trans. Kans. Acad. Sci. 21(1):180-188.
- Smyth, E.G. 1933. On the Nicolay and Weiss "Synopsis of the Cicindelidae" (Coleop.). Ent. News 44(8):197-204.
- Smyth, E.G. 1935. An analysis of the *Cicindela purpurea* Group (Coleop: Cicindelidae). Ent. News 46(1):14-19 and 46(2):44-49.
- Soils of Canada. 1972. Pedology and Cartographic Sections of the Soil Research Institute, Research Branch, Department of Agriculture, Ottawa, Canada. Scale 1:5,000,000. Lambert conformal conic projection, standard parallels 49°N and 77°N. Modified polyconic projection North of Latitude 80°. Printed by the Surveys and Mapping Branch, Department of Energy, Mines and Resources.
- Soil Survey Staff. 1960. Soil classification - a comprehensive system - 7th approximation: U.S. Dept. Agriculture Soil Conserv. Service. v + 265 pp.
- Soil Survey Staff. 1967. Supplement to soil classification system (7th approximation): U.S. Dept. Agriculture Soil Conserv. Service. v + 207 pp.
- Spanton, T.G. 1983. A revision of the Nearctic species of the *Cicindela sylvatica* group (Coleoptera: Cicindelidae). M.Sc. Thesis, Lakehead University. 175 pp., 81 figs.
- Spanton, T.G. 1988. The *Cicindela sylvatica* group: geographical variation and classification of the Nearctic taxa, and reconstructed phylogeny and geographical history of the species (Coleoptera: Cicindelidae). Quaest. Ent. 24(1):51-161.
- SPSS-X. 1986. User's guide, 2nd ed. SPSS Inc., Chicago, Illinois and McGraw-Hill Book Company, USA. xiv + 988 pp.
- Spurr, A.R. 1969. A low-viscosity epoxy resin embedding medium for electron microscopy. J. Ultrastruct. Res. 26:31-43.
- Steyskal, G.C. 1971. On the validity of *Cicindela cyanocephalonota* Eckhoff (Coleoptera: Cicindelidae). Coleopt. Bull. 25:34.
- Thornhill, R. and J. Alcock. 1983. The evolution of insect mating systems. Harvard University Press,

Cambridge, Massachusetts. xii + 547 pp.

- USDI. 1970. The National Atlas of the United States of America. Distribution of Principal Kinds of Soils: Orders, Suborders and Great Groups. National Cooperative Soil Survey Classification of 1967. Compiled by the Soil Conservation Service, 1967. Scale 1:7,500,000. Albers Equal Area Projection. United States Department of the Interior Geological Survey, Washington, D.C.
- Varas-Arangua, E. 1928. IV Contribucion al estudio de los Cicindelidae (Notas sobre las variedades de algunas especies de *Cicindela* del grupo *formosa purpurea oregona*). Rev. Chil. Hist. Nat. 32:231-251.
- Vaurie, P. 1950. Notes on the habitats of some North American tiger beetles. N.Y. Ent. Soc. 58:143-153.
- Wallis, J.B. 1961. The Cicindelidae of Canada. University of Toronto Press, Toronto, Ontario. xii + 74 pp.
- Ward, R.D. 1971. On spring collecting in Louisiana, Texas and Arkansas with notes on *Cicindela sexguttata tridens* Casey. *Cicindela* 3(4):69-77.
- Ward, R.D. and T.A. Bowling. 1980. *Cicindela* collected from malaise traps in Michigan and notes on the distribution of Michigan species. *Cicindela* 12(2):29-31.
- Watrous, L.E. and Q.D. Wheeler. 1981. The out-group comparison method of character analysis. Syst. Zool. 30(1):1-11.
- Werner, G. 1965. Untersuchungen über die Spermiogenese beim Sandläufer, *Cicindela campestris* L. Z. Zellforsch. mikrosk. Anat. 66:255-275.
- Westwood, J.A. 1831. Mémoire pour servir à l'Histoire naturelle de la famille des Cicindeletes (I). Annales des Sciences Naturelles. 22:299-317.
- Wickham, H.F. 1894. The Coleoptera of Canada. Can. Ent. 26(6):149-154.
- Wickham, H.F. 1899. The habits of American Cicindelidae. Proc. Davenport Acad. Nat. Sci. 7:206-228.
- Wickham, H.F. 1911. A list of the Coleoptera of Iowa. Bulletin Lab. Nat. Hist. State Univ. of Iowa 6(2):1-15.

- Wigglesworth, V.B. 1972. The principles of insect physiology, 7th ed. Chapman and Hall Ltd., New York, New York. viii + 827 pp.
- Wiley, E.O. 1981. Phylogenetics: The theory and practice of phylogenetic systematics. John Wiley & Sons, Inc., USA. xv + 439 pp.
- Williamson, P. 1974. The fine structure of ejaculated ram spermatozoa following scrotal heating. J. Reprod. Fert. 40:191-195.
- Willis, H.L. 1967. Bionomics and zoogeography of tiger beetles of saline habitats in the central United States (Coleoptera: Cicindelidae). Univ. Kansas Sci. Bull. 47(5):145-313.
- Willis, H.L. 1968. Artificial key to the species of *Cicindela* of North America north of Mexico (Coleoptera: Cicindelidae). Jour. Kans. Ent. Soc. 41(3):303-317.
- Willis, H.L. 1970. The Cicindelidae of Kansas. *Cicindela* 2(1):1-27.
- Willis, H.L. 1972. Tiger hunting in Kansas. The Kansas School Naturalist. 19(2):1-15.
- Willis, H.L. and J. Stamatov. 1971. Collecting Cicindelidae in the northwest. *Cicindela* 3(3):41-51.
- Wilson, D.A. 1970a. Three subspecies of Cicindelids threatened with extermination. *Cicindela* 2(2):18-20.
- Wilson, D.A. 1970b. Activity of Cicindelidae in relation to temperature. *Cicindela* 2(3):9-13.
- Wilson, D.A. 1978. The tiger beetles of Mount Desert Island and Acadia National Park, Maine. *Cicindela* 10(1):7-16.
- Wilson, D.A. and A.E. Brower. 1983. The Cicindelidae of Maine. *Cicindela* 15(1/4):1-33.
- Wilson, E.O. and W.L. Brown, Jr. 1953. The subspecies concept and its taxonomic application. Syst. Zool. 2(3):97-111.
- Zikan, J.J. 1929. Zur Biologie der Cicindeliden Brasiliens. Zool. Anz. 82:269-414.