

INFORMATION TO USERS

This manuscript has been reproduced from the microfilm master. UMI films the text directly from the original or copy submitted. Thus, some thesis and dissertation copies are in typewriter face, while others may be from any type of computer printer.

The quality of this reproduction is dependent upon the quality of the copy submitted. Broken or indistinct print, colored or poor quality illustrations and photographs, print bleedthrough, substandard margins, and improper alignment can adversely affect reproduction.

In the unlikely event that the author did not send UMI a complete manuscript and there are missing pages, these will be noted. Also, if unauthorized copyright material had to be removed, a note will indicate the deletion.

Oversize materials (e.g., maps, drawings, charts) are reproduced by sectioning the original, beginning at the upper left-hand corner and continuing from left to right in equal sections with small overlaps.

Photographs included in the original manuscript have been reproduced xerographically in this copy. Higher quality 6" x 9" black and white photographic prints are available for any photographs or illustrations appearing in this copy for an additional charge. Contact UMI directly to order.

**Bell & Howell Information and Learning
300 North Zeeb Road, Ann Arbor, MI 48106-1346 USA
800-521-0600**

UMI[®]

**Advances in Recycle Mill Supervisory Control
at Avenor Thunder Bay**

by

Ian Donovan ©

A Thesis

presented to Lakehead University

in fulfilment of the requirements for the Degree of

Master of Science in Control Engineering

Thunder Bay, Ontario, Canada, 1998



**National Library
of Canada**

**Acquisitions and
Bibliographic Services**

**395 Wellington Street
Ottawa ON K1A 0N4
Canada**

**Bibliothèque nationale
du Canada**

**Acquisitions et
services bibliographiques**

**395, rue Wellington
Ottawa ON K1A 0N4
Canada**

Your file Votre référence

Our file Notre référence

The author has granted a non-exclusive licence allowing the National Library of Canada to reproduce, loan, distribute or sell copies of this thesis in microform, paper or electronic formats.

The author retains ownership of the copyright in this thesis. Neither the thesis nor substantial extracts from it may be printed or otherwise reproduced without the author's permission.

L'auteur a accordé une licence non exclusive permettant à la Bibliothèque nationale du Canada de reproduire, prêter, distribuer ou vendre des copies de cette thèse sous la forme de microfiche/film, de reproduction sur papier ou sur format électronique.

L'auteur conserve la propriété du droit d'auteur qui protège cette thèse. Ni la thèse ni des extraits substantiels de celle-ci ne doivent être imprimés ou autrement reproduits sans son autorisation.

0-612-52051-X

Canada

ABSTRACT

This study examined supervisory control systems at Avenor Inc. Recycle Pulp Mill Thunder Bay making improvements in process control and automation. Supervisory controls were implemented for improving the control of a talc conveyor metering system to monitor and regulate the addition of talc to maintain a target talc concentration on mill pulp; in the implementation of a feed forward pulper discharge consistency control system to improve stock consistency control during pulper dilution and discharge to the retention chest; and to improve the operation of the Pulper Head tank Level Control System to reduce the impact of pulper head tank inventory changes on grey water chest inventory control and mill water makeup. Implementation of the talc supervisory control system achieved the desired steady state control of the talc concentration and reduced maximum excursions in the mill talc concentration to within 25% of setpoint. The talc control system eliminated the need to replace a malfunctioning density transmitter, resulting in capital cost savings. Feed forward pulper discharge consistency controls reduced the variance in phase 5 stock consistency entering the retention chest by 93%, eliminating undesirable valve oscillation on downstream consistency control loops associated with the high variability in the pulper discharge consistency. A proposed feed forward pulper head tank supervisory level controller demonstrated the possibility of reducing the variance in the pulper head tank feed by over 95%, thereby significantly reducing the impact of pulper head tank feed flow changes on mill water makeup and inventory control in the grey water chest.

Potential Sources of Flotation Inlet Brightness variation were also examined to determine the cause of excessive brightness variation and suggest possible solutions through the available on-line distributed control system mill technology.

ACKNOWLEDGEMENTS

I would like to thank Dr. A. F. Gilbert and Dr. K. Natarajan for their support and guidance throughout my graduate program. I would like to give special thanks to Mr. Ken Boegh for his continuous co-operation and technical advice during my work at Avenor. Finally, I would like to thank my family for their love and encouragement at all times.

TABLE OF CONTENTS

ABSTRACT	ii
ACKNOWLEDGEMENTS	iii
TABLE OF CONTENTS	iv
LIST OF TABLES	vii
LIST OF FIGURES	viii
CHAPTER 1: INTRODUCTION TO PULP RECYCLING OPERATIONS	1
1.0 Introduction	2
1.1 Pulping	7
1.1.1 Pulper Automation and Control	8
1.2 Flotation De-Inking	14
1.2.1 Classic Flotation De-Inking	14
1.2.2 Variables in Flotation Control	18
1.3 Contaminant Removal and Stickies Control	21
1.3.1 Physical Methods of Contaminant Removal: Screening and Cleaning	21
1.3.2 Chemical Methods of Contaminant Removal: Stickies Control	25
1.4 Clarification and Grey Water Inventory Control	28
1.5 The Impact of Recycling on Pulp Quality	30
1.6 Implications for Control at Avenor Recycle Mill, Thunder Bay	32
1.6.1 Pulping Control: Optimization of Pulper Conditions	32

1.6.2	Pulper Discharge Consistency Control	33
1.6.3	Flotation Control	35
CHAPTER 2:	TALC ADDITION CONTROL OF A SCREW CONVEYOR METERING SYSTEM	36
2.0	Introduction	37
2.1	Talc Control Problem Formulation	37
2.2	Control System Development and Implementation	39
2.3	Operator Controls	51
2.4	Operator Manual: Talc Screw Feed Conveyor Control System	54
2.5	Results and Discussion	57
CHAPTER 3:	AN INVESTIGATION INTO THE SOURCES OF FLOTATION CELL INLET BRIGHTNESS VARIATION	61
3.0	Introduction	62
3.1	Variables for Process Investigation: Results and Discussion	62
CHAPTER 4:	FEED FORWARD CONTROL OF PULPING CONSISTENCY DURING BATCH PULPER DISCHARGE	88
4.0	Introduction	89
4.1	Consistency Control Problem Formulation	94
4.2	Pulper Discharge Consistency Control Implementation	98
4.3	Results and Discussion	101

CHAPTER 5: FEED FORWARD PULPER HEAD TANK INVENTORY CONTROL ...	117
5.0 Introduction	118
5.1 Pulper Head Tank Feed Forward Control Algorithm	133
5.2 Results and Discussion	135
 CHAPTER 6: CONCLUSIONS AND FUTURE DIRECTIONS	 154
 APPENDICES	 156
APPENDIX A Talc Metering Control Sequence Code Algorithm	157
APPENDIX B Pulper Discharge Consistency Control Sequence Code Algorithm	166
APPENDIX C Pulper Head Tank Feed Forward Control Algorithm And Simulation Code	180
 REFERENCES	 202

LIST OF TABLES

Table 1.0	Standard Physical Parameters For Batch Pulping Operations	9
Table 1.1	Chemical Use in Flotation De-Inking	15
Table 1.2	Functional Groups For Ionic And Non-Ionic Surfactants	17
Table 1.3	Chemical Components In Stickies	26
Table 2.0	Summary of Talc Control Performance for Figure 2.8	60
Table 3.0	Summary of Flotation Inlet Brightness-Process Variable Correlations	65
Table 4.0	Dilution Water Addition Totals for Phase 5 Pulper Discharge	93
Table 4.1	Consistency Control Performance Under Supervisory and Conventional Controls	109
Table 5.0	Summary of Pulper Head Tank Feed Flow Variation Under Standard and Proposed Feed Forward Control Strategies	153

LIST OF FIGURES

Figure 1.0	Recycle Plant Process Flowsheet	3
Figure 1.1	Batch Pulper Phase Sequencing Operations	5
Figure 1.2	Grey Water Chest Temperature Control System	13
Figure 1.3	Standard Screening Configurations	22
Figure 1.4	Standard Pressure Screen Controls	24
Figure 1.5	Grey Water and Pulping Process Flowsheet	34
Figure 2.0	Original Talc Conveyor Control System Configuration	38
Figure 2.1	Talc Recirculation Process Flowsheet	40
Figure 2.2	Talc Metering Conveyor Supervisory Control System	41
Figure 2.3	Talc Conveyor Supervisory Control System Loop Diagram	42
Figure 2.4	Estimated Stock Recirculation Rate Based on Retention Chest Material Balance Calculations	48
Figure 2.5	Retention Chest Consistency Change During Stock Recirculation at 290 tons/day	49
Figure 2.6	Talc System Operator Console Window Display	52
Figure 2.7	Talc System Window Display Showing Operator Inputs and Controls	53
Figure 2.8	Estimated Talc Concentration on Pulp Achieved Under Supervisory Control For a Talc Concentration Setpoint of 1.5% odp	59
Figure 3.0	Typical Variation in Flotation Inlet Brightness During Plant Operation	63
Figure 3.1	Final Pulp Brightness Achieved From Flotation Inlet Brightness Variation of Figure 3.0	64

Figure 3.2	Flotation Inlet Brightness Variation for Figures 3.3, 3.4, 3.5, 3.8 and 3.13	67
Figure 3.3	Hydrogen Peroxide Chemical Dosage Variation Per Ton of Pulp	68
Figure 3.4	Sodium Hydroxide Chemical Dosage Variation Per Ton of Pulp	69
Figure 3.5	Hydrogen Peroxide/Sodium Hydroxide Ratio Variation During Pulping Operation	70
Figure 3.6	Flotation Inlet Brightness Variation For Figure 3.7	71
Figure 3.7	Hydrogen Peroxide/Sodium Hydroxide Ratio Variation	72
Figure 3.8	Sodium Silicate Chemical Dosage Variation Per Ton of Pulp	73
Figure 3.9	Flotation Inlet Brightness Variation For Figure 3.10	75
Figure 3.10	DTPA Chemical Dosage Variation Per Ton of Pulp.....	76
Figure 3.11	Flotation Inlet Brightness Variation For Figure 3.12	77
Figure 3.12	Percent Magazine Batch to Batch Pulping Variation	78
Figure 3.13	Retention Chest Plant Production Rate For the Flotation Inlet Brightness Variation of Figure 3.2	79
Figure 3.14	Flotation Inlet Brightness Variation For Figure 3.15	80
Figure 3.15	Retention Chest Plant Production Rate For the Flotation Inlet Brightness Variation of Figure 3.14	81
Figure 3.16	Flotation Inlet Brightness Variation For Figure 3.17	82
Figure 3.17	Retention Chest Plant Production Rate For the Flotation Inlet Brightness Variations of Figure 3.16	83
Figure 3.18	Flotation Inlet Brightness Variation For Figure 3.19	84
Figure 3.19	Retention Chest Plant Production Rate For the Flotation Inlet Brightness Variation of Figure 3.18	85

Figure 4.0	Batch Pulping Discharge and Grey Water Dilution Process Flowsheet	90
Figure 4.1	Calculated Phase 5 Discharge Consistency Achieved Under Conventional Consistency Control Operation	92
Figure 4.2	Change in Pulper Volume During Typical Phase 5 Discharge Operations	97
Figure 4.3	Retention Chest Outlet Minor Consistency Control Valve Position Under Conventional Pulper Discharge Consistency Controls	102
Figure 4.4	Retention Chest Production Rate Variation Under Conventional Pulper Discharge Consistency Controls	103
Figure 4.4a	Production Rate Variation Problems Under Conventional Consistency Control	104
Figure 4.5	Retention Chest Outlet Minor Consistency Control Valve Position Under Supervisory Pulper Dilution Consistency Control	105
Figure 4.6	Retention Chest Production Rate Variation Under Supervisory Pulper Dilution Consistency Control	106
Figure 4.7	High Density Cleaner Feed Consistency Variation Under Conventional Pulper Discharge Consistency Control	107
Figure 4.8	High Density Cleaner Feed Consistency Variation Under Pulper Supervisory Pulper Dilution Consistency Control	108
Figure 4.9	Pulper Level Change Under Supervisory Pulper Dilution Control	111
Figure 4.10	Phase 5 Discharge Line Grey Water Dilution Flow (FT123)	112
Figure 4.11	Phase 5 Pulper Dilution Flow (FT115)	113
Figure 4.12	Calculated Phase 5 Pulper Stock Consistency	114
Figure 4.13	Calculated Phase 5 Pulper Discharge Consistency	115
Figure 4.14	Operator Window Display Showing Pulper Discharge Consistency Control Toggle Point	116

Figure 5.0	Grey Water Chest Inventory Control System	119
Figure 5.1	Batch Pulping Grey Water Demand Phase Variation	120
Figure 5.2	Long-Term Pulper Head Tank Level Variation During Plant Operation	122
Figure 5.3	Long-Term Pulper Head Tank Feed Flow Variation During Plant Operation	123
Figure 5.4	Long-Term Grey Water Chest Level Variation During Plant Operation	124
Figure 5.5	Long-Term Grey Water Chest Makeup Water Valve Position During Plant Operation	125
Figure 5.6	Pulper Head Tank Level Batch Variation	128
Figure 5.7	Pulper Head Tank Feed Flow Batch Variation	129
Figure 5.8	Grey Water Chest Level Batch to Batch Variation	130
Figure 5.9	Grey Water Chest Makeup Water Valve Position Variation	131
Figure 5.10	Batch to Batch Tonnage Variation and Phase Times for Figures 5.11 and 5.12	136
Figure 5.11	Simulated Pulper Head Tank Feed Forward Level Control With Batch to Batch Tonnage Variations From Figure 5.10	137
Figure 5.12	Simulated Pulper Head Tank Feed Flow Under Feed Forward Control With Batch to Batch Tonnage Variations From Figure 5.10	138
Figure 5.13	Between Batch Pause Times and Phase Times for Figures 5.14, 5.15, 5.16, 5.17, 5.18, and 5.19	139
Figure 5.14	Simulated Pulper Head Tank Feed Forward Level Control With Between Batch Pause Delays	140
Figure 5.15	Simulated Pulper Head Tank Feed Flow Under Feed Forward Control With Between Batch Pause Delays	141

Figure 5.16	Simulated Pulper Head Tank Feed Forward Level Control With Between Batch Pause Delays and Under Conditions with a +5% Offset Between the Pulper Head Tank Setpoint Feed Flow and Actual Feed Flow	142
Figure 5.17	Simulated Pulper Head Tank Feed Flow Control With Between Batch Pause Delays and Under Conditions with a +5% Offset Between the Pulper Head Tank Setpoint Feed Flow and Actual Feed Flow	143
Figure 5.18	Simulated Pulper Head Tank Feed Forward Level Control With Between Batch Pause Delays and Under Conditions with a -5% Offset Between the Pulper Head Tank Setpoint Feed Flow and Actual Feed Flow	144
Figure 5.19	Simulated Pulper Head Tank Feed Flow Control With Between Batch Pause Delays and Under Conditions with a -5% Offset Between the Pulper Head Tank Setpoint Feed Flow and Actual Feed Flow	145
Figure 5.20	Recycle Plant Process Data Showing Batch to Batch Tonnage Variation, Between Batch Pause Times and Phase Times for Figures 5.21, 5.22, 5.23 and 5.24	148
Figure 5.21	Avenor Pulper Head Tank Level Control With Between Batch Pause Delays and Batch Tonnage Variation	149
Figure 5.22	Avenor Pulper Head Tank Feed Flow Variation With Between Batch Pause Delays and Batch Tonnage Variation	150
Figure 5.23	Feed Forward Pulper Head Tank Level Control With Between Batch Pause Delays and Batch Tonnage Variation	151
Figure 5.24	Feed Forward Pulper Head Tank Feed Flow Variation With Between Batch Pause Delays and Batch Tonnage Variation	152

Chapter 1

Introduction To Pulp Recycling Operations

1.0 Introduction

Avenor Inc. Thunder Bay operates a 450 ton/day recycled pulp mill, supplying recycled pulp for Avenor's newsprint operations. The plant has been in operation since 1991, producing recycled pulp from 70% recycled newsprint and 30% recycled magazine.

An overview of the Recycle Plant Process is shown in Figure 1.0. Pulping occurs in a batch mode, supplying inventory for the continuous operation of the plant from the retention chest. The final recycled product is stored in the high density tank for transfer to paper machine storage.

The primary objectives for recycling are to obtain pulp suitable for reuse in newsprint. Obtaining suitable product from waste paper requires the separation of plastics, metals and other contaminants from the feed stock, and removal of attached ink and filler material attached to the pulp fibres. The recycle process can thus be divided into two components: large scale contaminant handling by mechanical separation, and the removal of ink and colour bodies by chemical means. Large scale contaminant removal is achieved by the employment of high density cleaning, coarse screening, and forward and reverse cleaning stages throughout the process. Further removal of small sized contaminants (<0.5mm) is achieved with fine screening. Contaminant removal is a major component in the production of recycled pulp, primarily because of the large volume of contaminants present in waste paper supplies and the need to ensure a final product with acceptable visual and mechanical properties. The presence of contaminants negatively impacts on both paper quality and paper machine operation.

The visual quality of newsprint made from the recycled stock is a function of both the final pulp brightness and the size distribution of residual ink particles entrained in the pulp. Pulp brightness is defined as the ratio of the reflectance of an opaque pad of test sheets using light at 457 nm wavelength compared to the reflectance of a thick pure white magnesium oxide surface under the same conditions [1]. The modified Tappi Method T525, based on an absolute reflectance scale of 100, is the ISO standard for brightness measurement. Final pulp brightness values above 60.0 ISO are necessary for satisfactory overall paper appearance and colour. The control of ink removal and final pulp brightness is achieved through the use of flotation and dispersion stages. During flotation, the agglomeration of ink and other suspended contaminants with soap particles provides a means for contaminant transport and removal on rising air bubbles. This ink removal provides for brightness gains of 10.0-15.0 ISO brightness units.

Brightness is a direct measure of ink content for particle distributions under 40 µm. Larger particles remain visually unacceptable, but do not contribute significantly to brightness degradation. Therefore, in addition to brightness control, the particle size of residual ink carried with the final product must be sufficiently small to prevent the appearance of unsightly specks which degrade paper quality. The control of residual ink size is achieved through stock dispersion at high consistency.

Obtaining a recycled product of suitable appearance and printability requires removal of sufficient dirt and ink to obtain an ISO brightness of approximately 60.0-65.0. The brightness of repulped stock after coarse screening varies between 45.0-52.0 ISO units. Depending on the brightness gain across the flotation cells, post flotation pulp brightness ranges between 55.0-65.0.

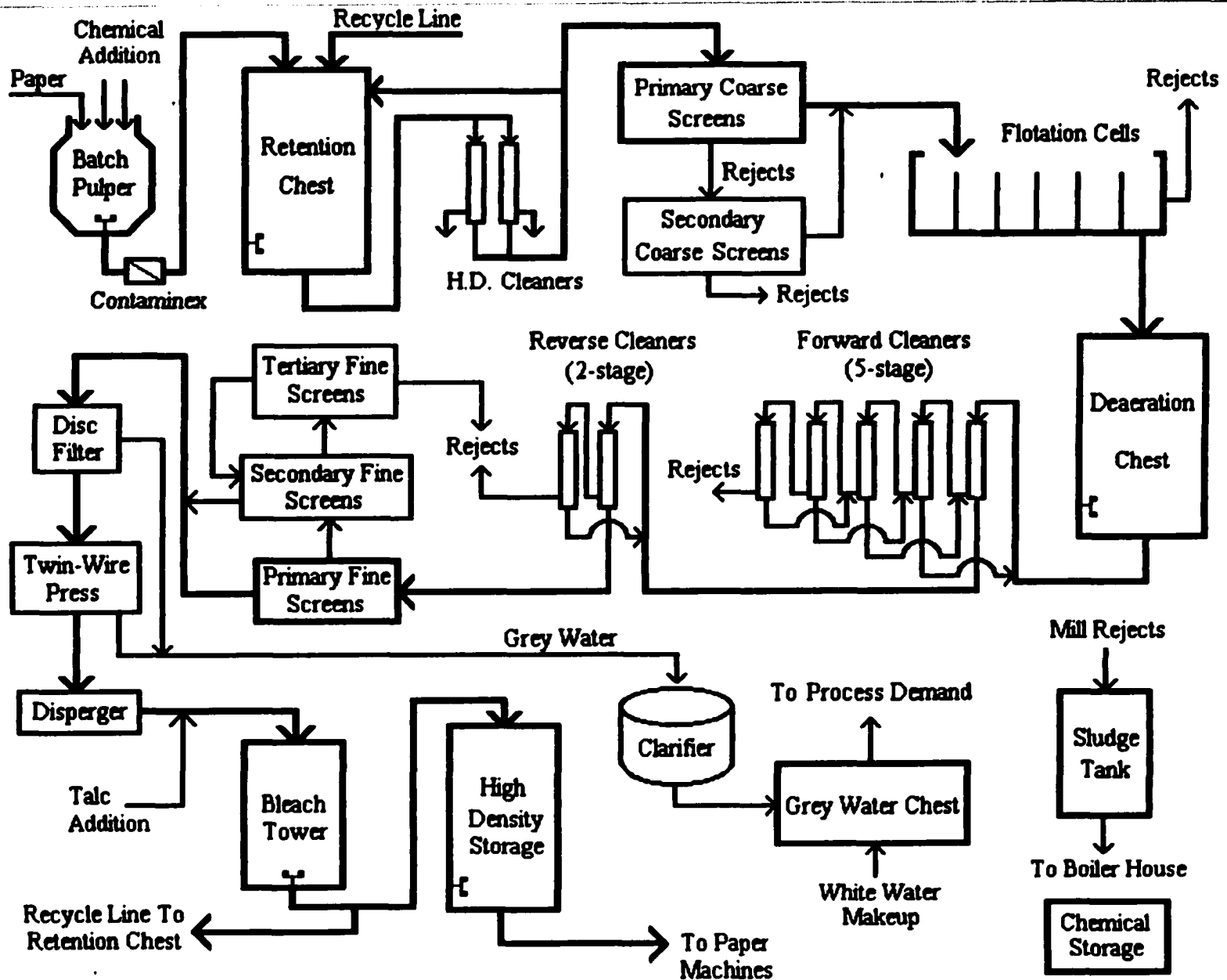

Figure 1.0 Recycle Plant Process Flowsheet

Low post-flotation brightness must be compensated by further chemical addition or reprocessing. Sodium hypochlorite and sodium hydrosulfite can be added for additional bleaching and colour removal during the final stages of recycling. Alternatively, Figure 1.0 shows the potential for pulp recirculation to the retention chest for reprocessing in the event of poor production quality.

Batch pulping operates on a 7-phase automatic sequence, with each batch lasting between 22.0-27.0 minutes. Batch operation is controlled by a Unix based DCS sequence algorithm, which controls the timing and material handling for each phase to allow manual or automatic execution of the batch cycle. Figure 1.1 shows the pulper phase sequencing. Phases 1 and 2 complete the addition of water, chemical and paper to the pulper in preparation for phase 3 slushing. Phase 4 stock pre-dilution reduces the stock consistency from 16% to 10% in preparation for phase 5 discharge. During phase 5, pulper stock is further diluted to 4.5% consistency and discharged to the retention chest. Upon completion of phase 5 a new batch sequence begins in phase 1, while the previous batch continues operation into phases 6 and 7. During phase 6, the Contaminex screens are back flushed with dilution water to recover trapped stock before discharging the screen rejects for disposal during phase 7. With the concurrent operation of two batch sequences, the total batch time has been reduced to 17.0-22.0 minutes.

The regulation of chemical addition for the pulping process is controlled via flow and accumulator controls, which meter the chemical dosage in proportion to the batch tonnage. Two conveyors feed the pulper with 70% newspaper and 30% magazine respectively. The conveyors are equipped with nuclear gauge mass flowmeter controls to measure and accumulate the total paper added to the pulper each batch. The mass flow controller manipulates conveyor speed to control the total paper addition to each batch.

Feed from the retention chest enters a series of cleaning stages in preparation for flotation. The high density cleaners operate at consistencies of 2-3% and function to remove large particles with specific gravity greater than 1.0 such as dirt, grit and glass. The primary and secondary coarse screens remove contaminants greater than 1.0-2.0mm in diameter.

Accepts from the primary and secondary coarse screens are fed to the flotation cells, where soap and calcium chloride are added. In the flotation cell ink and other contaminants are separated from the pulp fibres, agglomerated, and floated on the surface for removal. The de-inked stock is then fed to the deaeration chest to remove air entrained during flotation.

From the deaeration chest the pulp enters a three stage process further remove contaminants. The 5-stage forward cleaners operate in cascade mode to separate high density contaminants such as sand, adhesives and inks. The forward cleaners operate at consistencies between 0.6%-0.8%. Forward cleaner accepts then feed the reverse cleaners, where waxes, plastics, adhesives and other low-density materials are removed. Fine screens provide removal of particles greater than 0.15 mm diameter.

After screening the stock enters a series of thickening stages, raising the pulp consistency to 30% in preparation for dispersion. After dispersion, the thickened pulp enters the bleaching and storage area of the plant. Originally the bleach tower was designed to provide a second stage of peroxide bleaching, however subsequent operation demonstrated that tower bleaching was unnecessary for satisfactory brightness gain. The bleaching tower now serves only as a storage and dilution tank. Bleach tower stock is fed to the high density storage tank at 8.5% consistency

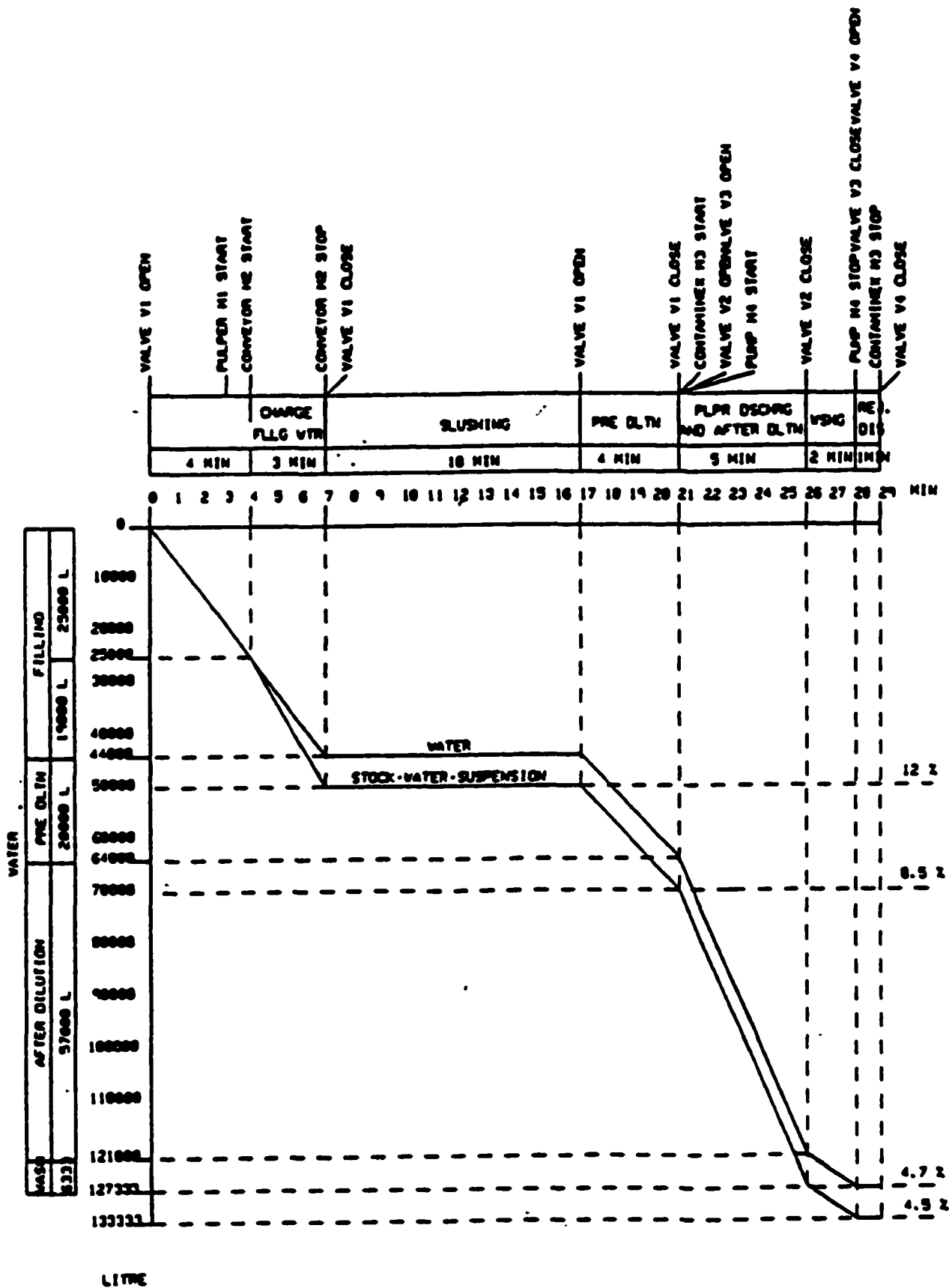

Figure 1.1 Batch Pulper Phase Sequencing Operations

for subsequent dilution and transport to the paper machine storage tank.

The grey water chest serves as inventory storage for grey water throughout the plant, supplying process water demand to all plant areas prior to the bleach tower. All dilution water supplied after twin-wire press thickening is provided from the paper machine white water tank.

Process dilution water for use within the plant is recirculated to the grey water chest from the thickening stages. Dilution water is supplied from the grey water chest for consistency control during batch pulping, coarse screening, flotation, cleaning and fine screening. Stock consistency falls from 4.5% at the retention chest, to 1.1% at the flotation inlet, to 0.5 % at the disc filter before thickening to 30% for dispersion. Most of this dilution water subsequently returns to the grey water chest after thickening and clarification for reuse. During normal operation, however, approximately 500 L/min of grey water is lost to the pulp exiting the plant, with an additional 2000 L/min lost with stock rejects entering the sludge tank. These losses must be made up by addition of paper machine white water to the grey water chest.

The recirculation of grey water requires clarification and chemical handling to prevent the accumulation of suspended inks and other contaminants suspended in the aqueous phase. Bentonite and polymer surfactant are used during clarification of disc filter and twin-wire press grey water before recirculation to the grey water chest for further use.

After the coarse screening stage, the recycle plant operates as a constant flow process. Irrespective of production rate, the total flow entering the flotation cells is controlled at approximately 18500 L/min by adjusting the flotation inlet grey water dilution flow. The use of a constant flow regulation scheme is necessary to prevent level upsets in the flotation cells, which negatively impact on fibre loss and ink removal efficiency during flotation. Consequently, the flotation inlet consistency is allowed to vary between 0.9%-1.7% when plant production varies between 250-450 tpd.

1.1 Pulping

Pulping is critical to the overall recycling effectiveness: failure to separate fibre from contaminants prevents efficient ink removal and cleaning in subsequent stages. The key to pulping is production of completely separated stock. This involves separation of paper bales and water penetration into the paper, intimate wetting of paper fibres to cause weakening of inter-fibre bonds, and separation of fibres from contaminants such as inks, adhesives and garbage with minimal destruction of contaminants.

Common pulping options include low consistency continuous pulping at 3-4% consistency, low consistency batch pulping at 5-7% consistency, and high consistency pulping (12-20%) [2]. The wetting of the fibre is critical to separation, with paper type, pH, chemical addition and basis weight being factors affecting wetting rate.

Higher consistency pulping increases fibre-fibre contact, which aids in the separation of fibres and ink. Higher consistencies produce smaller ink particles which are harder to float, and reduce mixing efficiency. At high enough consistencies, the high resistance to flow from the pulp suspension again results in lower shear stresses and poor ink-fibre separation [2].

High consistency pulping at Avenor employs a helical rotor, which is very large in comparison to the low consistency rotor types. The flow pattern in a high consistency pulper is top to bottom, and the ratio of rotor-to-pulper volume is much higher (0.1% in lower consistency pulping and 8% in high consistency pulping). The low rotor speed (8-15 m/s versus 16-20 m/s for low consistency pulping) reduces the cutting of plastic contaminants and thereby ensures their easier removal later. Shearing forces are high due to the large velocity difference between rotor and stock, while mechanical forces remain low. The defibering action is produced by fibre to fibre contact rather than rotor mechanical forces [2]. Phase 3 slushing at Avenor occurs at 16% consistency.

The pulper can be discharged with or without screening, but lack of preliminary screening exacerbate contaminant build-up in the retention chest. Generally, pulper stock is diluted to 5% consistency and sent through a de-trashing screen for large size contaminant removal. The screen is back flushed at the end of each cycle to remove contaminants; these rejects can be de-watered and the recovered water returned to the cycle. Avenor currently employs a Contaminex detrashing system for screening large contaminants during pulper discharge.

In contrast, low consistency pulping depends on high mechanical forces which tear both paper and contaminants alike. Shear forces occur when opposite ends of a fibre are exposed to stock flowing in opposite directions. Contact between high-speed rotating and stationary plates create large mechanical forces which break the fibres apart. Mechanical forces between the rotor and fibre predominant over fibre-fibre interactions. The flow pattern in the pulper is a vortex, and baffles are necessary to improve mixing. Low consistency pulping is generally used only for old corrugated containers.

High consistency pulping offers several advantages, including reduced contaminant breakdown, reduced power consumption by up to 70%, chemical savings from higher chemical concentrations for the same tonnage as consistency increases, higher freeness, and higher ink removal. Large fibre-fibre interactions during high consistency pulping produce a smaller average ink particle size, resulting in poorer flotation and/or washing efficiencies; however, the improved

ink removal and prevention of contaminant break-down leads to higher final pulp brightness.

Pulping consistency is controlled by dilution water addition through flow controllers FT115 and FT123 (see Figure 1.5). Batch sequence controls automatically calculate and monitor the addition of grey water in each phase to achieve the correct pulper consistency. The total addition of grey water during phases 1 and 2 is calculated from the batch tonnage to achieve a phase 3 slushing consistency of 16%. Flow accumulator controls for phases 4, 5 and 6 regulate the total addition of grey water by the end of each phase.

The total time for batch pulping varies between 20 and 30 minutes. At Avenor, the batch sequence is divided into 7 stages, with slushing times varying between 2 and 12 minutes. Slushing time is automatically controlled by the batch sequence controller, and can be adjusted manually by the operators. Adequate slushing time is necessary to allow complete wetting of the wastepaper and maximum contact between fibres to disengage fibre from ink. As slushing time increases, a point is reached at which further separation between pulp and ink is impossible. Beyond that point further slushing increases contaminant dispersion and ink particle entrainment into the interior of pulp fibres where they cannot be removed by further processing [3]. This results in a higher concentration of residual ink remaining in the fibres, and lower final brightness.

1.1.1 Pulper Automation and Control

There are many factors which effect the de-inking process, including pulping consistency, slushing time, temperature, total alkalinity, sodium hydroxide, hydrogen peroxide, and sodium silicate addition, chelating agents, water hardness and the presence of dissolved metal ions. Typical pulping conditions are indicated in Table 1.0, and discussed below.

Maximal brightness gains from pulping therefore requires the controlled addition of hydroxide, silicate, peroxide and chelating agents. Pulper chemical addition at Avenor is summarized in Table 1.0. To obtain maximal brightness gains on recycled pulp requires control of the relationship between total alkalinity and peroxide concentration. Total alkalinity is defined as [4]

$$\text{Total Alkalinity} = \text{NaOH (\%odp)} + 0.112 * \text{silicate (\%odp)} \quad (1.1)$$

(%odp)

where % odp represents the chemical tonnage per ton oven dried pulp in percent, and is controlled by the addition of sodium hydroxide and sodium silicate. Controlled addition of hydroxide, silicate, peroxide and chelating agents by flow controlled metering pumps is necessary for proper pulper addition. Chemical addition setpoints are calculated from the total batch tonnage prior to phase 2 chemical addition.

Sodium hydroxide is used during pulping to enhance de-inking effectiveness by increasing the alkalinity for saponification and hydrolysis of resins, contributing to fibre flexibility and improved bonding, and maximizing the production of perhydroxyl anions for

Table 1.0 Standard Physical Parameters For Batch Pulping Operations

Parameter	Range	Avenor [3]
pH	9.5-10.5	9.5
Temperature	45-55°C	50 °C
Consistency	5-16%	14-16%
Slushing Time	3-12 minutes	2-8 min
Sodium Hydroxide	0.8-1.5% odp	0.8-1.1% odp
Sodium Silicate	1.0-3.0% odp	1.8% odp
Hydrogen Peroxide	0.5-2.0% odp	1.0% odp
Chelant	0.14-0.4% odp	0.3% odp
Surfactants	0.24-1.5% odp	0.5% odp
% Magazine	0-50%	20-30%

bleaching. Caustic allows for faster wetting of inter-fibre hydrogen bonds, thereby aiding wastepaper disintegration. Hydroxide reverses the effects of drying, allowing for improved strength properties and water retention.

Sodium hydroxide hydrolyses ester groups in print particles and saponifies ink resins, allowing them to dissolve and eventually be removed. Typically, hydroxide is added in conjunction with sodium silicate to control the total alkalinity. Sodium hydroxide is responsible for 'alkali darkening' in wood-containing pulps, which causes pulp fibres to yellow and darken, reducing brightness. The production of chromophores, or colour bodies, in lignin increases sharply above pH 5.5, and must be controlled by addition of hydrogen peroxide, as discussed below [5].

Increasing hydroxide addition from 0.4% odp to 1.2% odp reduces average ink particle size from 25 μm to 20 μm , total ink coverage from 8% to 2%, and the ERIC (Evaluation of Residual Ink Content) number from 390 ppm to 95 ppm [6]. Reducing or eliminating the use of caustic offers many advantages. Reduced dispersion and tack of pressure sensitive adhesives, reduced dissolution of organics with consequent reduction in BOD and COD, reduced foaming problems, lower costs associated with lower demand for peroxide to prevent alkali darkening, and increased safety [2].

Sodium silicate is a mixture of silicon dioxide and disodium oxide, typically in a ratio of 3.3/1. Silicate forms colloidal structures with heavy metal ions and stabilizes the environment to prevent peroxide decomposition; it acts as an ink dispersant, preventing ink deposition on fibre surfaces. Sodium silicate action is ascribed to its detergency: the ability to wet, disperse, emulsify and suspend soils in aqueous systems. A significant brightness gain during flotation deinking can be obtained from sodium silicate independent of brightness gains from peroxide bleaching. This additive brightness gain behaviour from silicate may be due to the fact that silicate reacts rapidly with calcium ions to form precipitates [4]. Thus silicate may react with ink particles in a similar way to that observed with soap during flotation. As an ink collector, silicate combines small ink particles to form macro-particles ($>10 \mu\text{m}$) suitable for flotation.

Other roles claimed for silicate include stabilization of peroxide by pH buffering. Silicate has been shown to significantly reduce the degree of alkali darkening, particularly at higher alkalinity (2%) [7].

Sodium Silicate contributes to the total alkalinity of the pulper solution through the reaction:

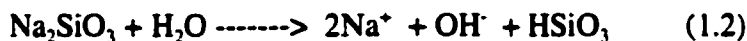

An additional source of brightness gain can be achieved by the use of magazine stock in conjunction with old newsprint. Magazines consist of coated papers bounded by glue and staples, and composed of fillers such as clay, alum, and calcium carbonate in proportions from 10% to 50% of the sheet weight. The use of recycled magazine offers a higher brightness gain than similar conditions with 100% newsprint. This effect is likely due to the high level of silicates and other clays present in old magazines, which function in a similar manner to sodium silicate [8]. While improving brightness gains, the presence of adhesives, thermal plastics and hot melts in magazine also contributes to stickies problems, as discussed in Section 1.3.

Magazine addition at Avenor typically comprises 20% of total batch tonnage. Newspaper and magazines are fed by separate conveyors to the pulper, with the ratio of newspaper to magazine addition controlled through the magazine conveyor speed feeding the pulper. With the magazine conveyor running at 20% of newspaper conveyor speed, an approximate magazine/newspaper ratio of 20% can be achieved. The total batch tonnage remains controlled by a nuclear mass flowmeter on the pulper feed line, which automatically shuts off both conveyor motors when the setpoint tonnage is reached. Control of the batch percent magazine is subject to errors from uneven loading of stock on the conveyors. The amount of material on each conveyor must be judged visually, providing only approximate control. Air pockets or blockage on one of the conveyors can result in less paper feeding the pulper than intended by the ratio of conveyor speeds. Adequate control has been achieved by monitoring the total addition of newspaper and magazine each shift to identify and correct imbalances in magazine/newsprint addition associated with improper feeding of the conveyors.

To prevent the brightness degradation associated with alkali darkening at high alkalinity, hydrogen peroxide must be added during pulping. Hydrogen peroxide acts as a bleaching agent to decolorize chromophores produced during alkaline pulping of lignin-containing fibres. The bleaching properties of peroxide is due to oxidizing properties of the perhydroxyl anion (OOH^-), produced in alkaline conditions in the presence of caustic:

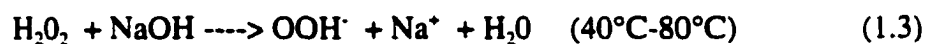

The amount of perhydroxyl anion can be maximized by higher pH, higher temperature, more peroxide, and removal of peroxide decomposing agents. The primary purpose of peroxide addition in the pulper is to prevent alkali darkening. Lower pulper temperatures (50°C), necessary to prevent stickies dissolution, lower consistencies and shorter retention times makes the use of peroxide for bleaching inappropriate in the pulper. Tower bleaching, with temperatures above 70°C , 25-30% stock consistencies and retention times above 50 min are better suited to peroxide bleaching. During both pulping and tower bleaching, it is necessary to maintain a residual level of hydrogen peroxide to prevent brightness reversion [4]. The addition of peroxide is set by the measured batch tonnage after phase 1 to achieve a dosage of 1.0% odp. Peroxide addition is regulated by flow accumulator controls.

Without hydrogen peroxide use in the pulper, the brightness gain after flotation drops due to alkali darkening when the total alkalinity is above 0.6% odp [4]. By using peroxide, the optimum level of total alkalinity increases with the peroxide dosage, enabling the advantages of better ink removal associated with higher alkalinity to be obtained without brightness loss. In addition, the optimal brightness gain becomes significantly less sensitive to changes in total alkalinity at higher peroxide levels. Consequently, the use of peroxide helps stabilize brightness gains against alkalinity disturbances from changing temperatures, pulp consistency, ONP/OMG ratio, paper age, and contaminant levels. For a given peroxide dosage, the total alkalinity can be measured by the pH, and controlled for optimal brightness gain [9].

Peroxide destroying agents include metal ions and aerobic micro-organisms. Metal ions such as copper, iron and manganese, in the presence of high temperature and pH, decompose peroxide to water and oxygen. Chelating agents and silicate are commonly used in the pulper to

block the effects of metal ions on peroxide [5]. Diethylenetriaminepentaacetic acid (DTPA), ethylenediaminetetraacetic acid (EDTA) and diethylenetriaminopentamethylene phosphonic acid (DTPMP) are common examples of chelants, used to form soluble complexes with metal ions to prevent catalytic decomposition of hydrogen peroxide. At Avenor, flow controlled addition of DTPA at 0.3% odp is used to protect against peroxide degradation during pulping. Chelant is also commonly added during dispersion, tower bleaching or H.D. storage at 0.1-0.4% odp depending on bleaching requirements [5]. Catalase, an enzyme produced by aerobic microorganisms present in waste papers and waste water recycled from the paper machines, also decomposes peroxide as a biochemical means to protect the cell from oxidation. The use of biocides such as peracetic acid, thermal shock treatment above 70 °C, and large shock doses of peroxide have been used to control microbial levels [4].

Pulping chemical dosage at Avenor is controlled by the use of flow and accumulator controls on all chemical feed lines. The total addition of peroxide, sodium hydroxide, sodium silicate and DTPA for each batch are pre-determined from the measured phase 1 batch tonnage addition to the pulper in order to provide the optimal chemical dosage on odp.

Pulping temperature control is necessary to optimize fibre wetting and minimize contaminant dispersion control. Higher temperature decreases water viscosity, thereby increasing the speed of water penetration into fibres and changing the stock circulation pattern inside the pulper. Higher pulping temperatures significantly reduce pulping times from 40 minutes at 21°C to 12 minutes at 66°C. Higher temperatures (above 55 °C) increase ink and contaminant dispersion and fibre yield losses [2]. Pulping temperature at Avenor is maintained at 50°C through temperature controls on the grey water chest. Figure 1.2 shows the control configuration. Clear grey water, makeup water, clarifier water and heated grey water enter the grey water chest through a smaller overflow weir before mixing with the rest of the grey water chest inventory. Temperature measurement in the weir basin allows immediate detection of changing incoming water temperature, enabling earlier response to feed temperature disturbances. Temperature control is maintained by the intermittent use of a heat exchanger. In response to low grey water chest temperature, grey water is circulated through a heat exchanger for heating before returning to the grey water chest. The heat exchanger adjusts the steam input rate to maintain the correct grey water temperature to compensate for the drop in grey water feed temperature. Grey water flow to the heat exchanger remains active while the grey water chest feed temperature remains below setpoint. High grey water chest temperature is compensated by the addition of fresh water, which remains below 15°C throughout the year.

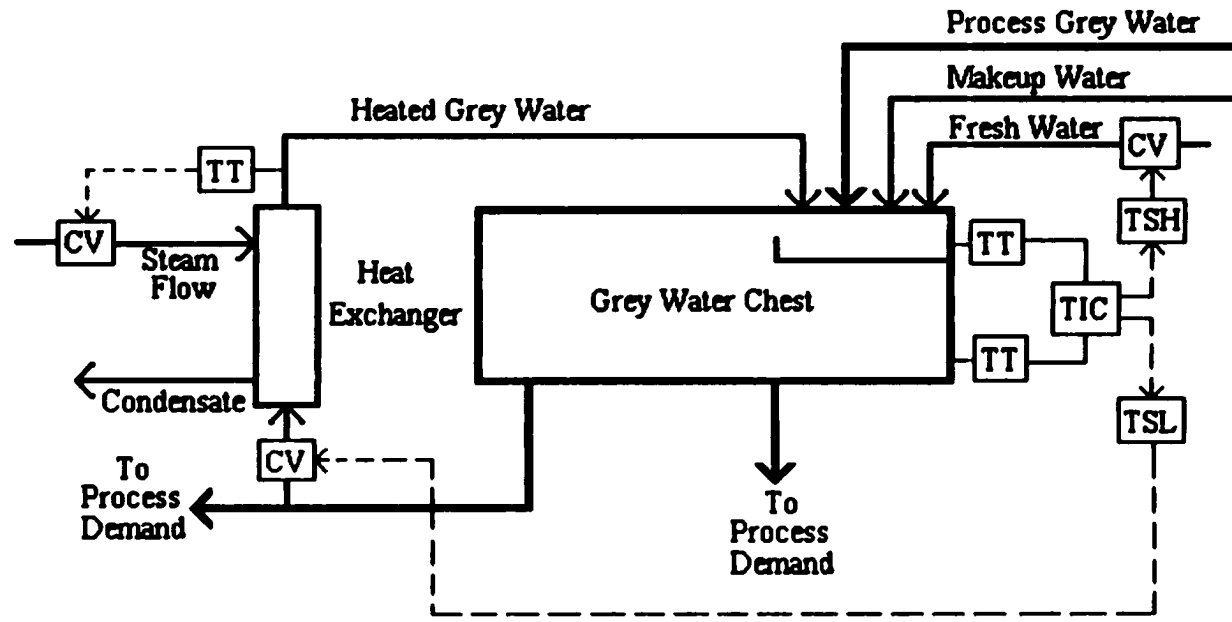

Figure 1.2 Grey Water Chest Temperature Controls

1.2 Flotation De-Inking

The purpose of de-inking is to separate ink and contaminants from the pulp fibres. During pulping, ink and other contaminants are broken down into particles with a typical size distribution from 1 μm to 1000 μm . Wash de-inking is effective for removing ink particles from 2 μm to 20 μm in size; particles between 20 μm and 100 μm are best removed by flotation, with larger particles removed by centrifugal cleaners and screens [4]. Brightness is a direct measure of ink content for particle distributions under 40 μm . Larger particles are visually unacceptable, but do not contribute significantly to brightness. Hence washing and flotation offer the best means to increase brightness in recycle pulps. Typically recycle plants employ only one of these methods for contaminant removal.

Flotation involves the separation of ink from fibre by attachment to air bubbles, which causes the ink to rise to the surface where it can be removed. It is based on the principle that ink particles, with the exception of water based inks, are more hydrophobic than pulp fibres, and will therefore preferably attach to air bubbles than remain suspended in the aqueous phase; this difference in hydrophobicity allows for separation. The sludge collected from flotation can be further thickened and burned or landfilled, with considerably less fibre and filler loss than in wash de-inking processes. Table 1.1 outlines the major chemical use in flotation de-inking.

1.2.1 Classic Flotation De-Inking

Because of the non-polar character of air bubbles, only non-polar particles can attach and float on air bubbles. In order to effect flotation of suspended particles, their hydrophilic nature must be destroyed. In the case of polar particles, adhesion forces between water and particle are stronger than cohesion forces between water molecules, causing water to cover (wet) particles in an orientated fashion. This 'hydrate layer' functions as a barrier between particles and air bubbles, preventing particle attachment to air bubbles [10].

During pulping, the high negative charge on ink particles and fibre alike produces electrostatic repulsion and stabilization, making possible the separation of ink from fibre [11]. Due to the presence of organic acids and acid functional groups in print, ink particles obtain a highly negative ($\approx -65\text{mV}$) zeta potential under alkaline conditions. The addition of calcium soaps causes the hydrophobic ends of soap molecules to adsorb on ink surfaces, raising the zeta potential (less negative) and favouring agglomeration.

The presence of calcium ions and fatty acid soaps produces insoluble soap salts, which precipitate on the surface of ink particles, giving the ink particle a rigid hydrophobic surface, making attachment to air bubbles possible. Calcium ions also lower the net charge on ink particle complex, making possible the aggregation of smaller ink particles into larger ones. This agglomeration and attachment to air bubbles provide the mechanism for the flotation of ink.

In classic flotation de-inking, surfactants function by destroying the hydrate layer between air bubble and water and ink particle and water. On contact with an air bubble, the hydrophilic end of the surfactant orients towards the water phase, while the hydrophobic end orients towards the hydrophobic air bubble. This stabilizes the air-water interface, causing frothing. An identical situation exists with the hydrophobic ink particles, which display hydrophilic behaviour and

Table 1.1 - Chemical Use in Flotation De-Inking [2]

Chemical	Concentration	Addition Point
Chelating Agents	0.0-0.5% odp	Cells
Soap	0.25-1.0% odp	Cells/Pulper
Calcium salts	60 ppm	Cells
Talc	0.0-1.5% odp	Cells/Final stock
Sodium Hydroxide	pH control	Cells
Sulfuric acid	pH control	Final stock
Sodium Hypochlorite	Brightness control	Final stock
Sodium hydrosulfite	Colour control	Final stock

dispersion in water. However, this hydrophilic behaviour prevents particle attachment to air bubbles. With hydrophilic molecules, the hydrophilic end of the surfactant orients towards the particle surface, enabling the hydrophobic end of the surfactant to extend towards the water phase. This disturbs the hydrate layer around the particle, and in the event of an air bubble-particle collision, makes possible the attachment of the particle to air bubble. More general models proposed to explain the function of surfactants (anionic, cationic and amphoteric) with hydrophobic and hydrophilic particles are explained below.

Surfactants function by changing surface tension. Surfactants used in flotation de-inking usually contain ethoxylated chains for the hydrophilic ends. The ratio of hydrophobic to hydrophilic size of a surfactant molecule, the hydrophile-lipophile balance value (HLB), is used to characterize the hydrophobic/hydrophilic nature of surfactants. A high HLB surfactant is readily soluble in water, and is predominantly hydrophilic in nature. Optimum HLB values for flotation are approximately 15 [9]. The surfactant degree of saturation (Iodine Value) also effects flotation. Single bonded surfactants show better ink dispersal and higher overall performance. Optimal brightness gain for surfactants with varying Iodine values was found to depend on water hardness, with high hardness levels being required or higher Iodine value surfactants.

Surfactants are divided into ionic and non-ionic forms; non-ionics do not ionize in water. Non-ionic surfactants offer the advantage of solution activity constants independent of water hardness. Ionic surfactants are of three types: anionic, cationic and amphoteric, depending on the charge of the molecule in the dissociated state. Amphoteric compounds can dissociate into either anions or cations depending on pH. Standard surfactant types are listed in Table 1.2 [12].

The effectiveness of surfactants use in de-inking operations depends on the type of ink present in waste paper. Ink particles from offset, letterpress and rotogravure ink show hydrophobic behaviour, and are negatively charged. As a result of adsorption by surfactant molecules, the hydrophilic end of the surfactant dissolves in the water phase, producing hydrophilic particles which resist flotation [13]. The efficiency and mechanism of flotation depends on the type of surfactant, ionic or non-ionic. In all cases, the hydrophilic particles suspended in the water phase, must be brought into contact with air bubbles.

In the presence of hardening constituents like calcium and magnesium ions, anionic surfactants interact to form bridges between other ink particles and air bubbles. The presence of positively charged ions joining particles and bubbles together is essential; at low water hardness the efficiency of anionic surfactants is poor [13].

To effect flotation of hydrophilic inks, surfactants function to produce hydrophobic particles complexes that can stabilize on air bubble surfaces. The particle surface of hydrophilic (flexo) inks readily dissolves in water. Because of their positively charged hydrophilic end, cationic surfactants are readily absorbed on negatively charged ink particles, forming a hydrophobic surface layer which readily attaches to hydrophobic air bubbles. Calcium ions, which readily absorb to ink particles, decrease the effective absorption of cationic surfactant on ink and thus lower the achievable brightness gain (compared with the use of distilled water) [14]. Nevertheless, brightness increase from hydrophilic inks and cationic surfactants is highest, typically 90% higher than anionic surfactants and 40% higher than non-ionic surfactants. Because of the favourable electrostatic attraction, cationic surfactants are unaffected by pH

Table 1.2 Functional Groups For Ionic And Non-ionic Surfactants

Non-ionic	Anionic	Cationic	Amphoteric
Alkyl	Sulphonates	Ammonium	Amino acids
Alkyl-Aryl	Sulphates	Pyridinium	
Acyl	Phosphates	Imidazolinium	
Acylamino	Carboxylates	Sulphoxonium	
Acylamide		Piperidinium	
Alkanoamides			
Polyoesters			

between 5 and 9.

Due to their negatively charged hydrophilic moiety, anionic surfactants are poorly absorbed on hydrophilic ink particles. Consequently, brightness gain is very poor. The presence of calcium ions, by lowering the effective surface charge of ink particles and acting to bridge surfactant and ink particles, improves surfactant absorption to a limited extent. Lower pH improves the performance of anionic and non-ionic surfactants by 200% between pH 9-5. This is explained by the lower repulsive forces between particle and surfactant at the isoelectric point of the surfactant [14].

1.2.2 Variables in Flotation Control

Flotation requires print particles that can adhere to air bubbles and float. This is best obtained with particles 10-150 μ m in diameter which have been separated from fibre. The flotation of ink occurs in five stages, including: a) ink particle detachment from the fibre surface or interior; b) ink particle contact with collector chemicals c) the ink-collector complex must collide with an air bubble d) the air bubble must carry the complex to the surface e) the floated ink must be removed from the system [9].

At constant air flow and bubble size, the flotation kinetics for ink particles of constant diameter is first order with respect to droplet concentration. This is expressed by:

$$\ln [N] = -kt + \ln [N_0] \quad (1.4)$$

where t = reaction time
k = rate constant
N = Number of ink particles at time t
N₀ = Number of ink particles at t=0

The rate constant k is proportional to the particle diameter to the power K, where K is between 1.2-1.8. The rate constant is also a function of bubble size distribution, contaminant type, chemical usage, temperature, flotation cell design and pulp consistency [15]. Flotation efficiency is optimal for particles sizes between 10-100 μ m. Pre-flotation mechanical cleaning and pulping determine the particle size distribution, and thereby effect particle floatability [2]. The probability of collision between ink complex and air bubble increases with larger particles and smaller air bubbles. Smaller bubbles also increase fibre losses: a minimum bubble size of 0.3-0.5 mm is cited [2]. Control of bubble size depends on the proper selection of orifice diameter for the required total air flowrate. Optimal flotation performance therefore depends on control of a number of factors both during plant design and process operation, as discussed below.

Water hardness during flotation is controlled by addition of calcium chloride prior to flotation. Calcium chloride flow rate is set in ratio to the plant production rate. In order for fatty acid soaps to act as collectors during flotation, a minimum hardness of 179 mg/L as CaCO₃ is necessary. Higher levels increase fibre losses, possibly due to the formation of large ink-calcium soap complexes. These complexes precipitate on pulp fibres, making the fibres hydrophobic and

float more easily.

Calcium ions readily attach to fibres, causing the fibres to become sufficiently hydrophobic to float. The absorption of calcium ions significantly reduces the negative charge of pulp fibres, which in conjunction with the presence of hydrophobic groups on the fibres, causes the fibres to float. It is the interaction of calcium ion with ink components, particularly carbon black, that causes fibre loss, rather than calcium ions alone. Unprinted pulp does not float, regardless of calcium ion concentration. Carbon black is a major component in printing ink which effects the floatability of fibres. When covered with functional groups capable of interacting with calcium ions, carbon black causes fibres to float. However, when covered by oil or polymerized print networks, carbon black does not contribute to fibre loss despite of the presence of calcium ions. The presence of resin-like lignin residues in pulp also cause fibre loss through similar interactions with high calcium ions at high concentrations [11].

Optimal flotation stock consistency varies between 0.8-1.5%, with lower ink removal efficiency above 1.5%. Higher consistency increases the drag on the ink-air complex, reducing rise velocity and dislodging ink particles from the bubble [16]. Avenor currently does not control the stock consistency during flotation. In order achieve better level control across the flotation cells, and thereby improve foam stability by minimizing changes in the flotation rejects rate, the inlet flowrate to the flotation cells has been maintained at a constant flow of approximately 18500.0 L/min. As a consequence of this strategy, the flotation inlet consistency fluctuates between 1.7%-0.9% as the production rate changes between 250-450 tons/day. At suboptimal flotation consistencies above 1.5%, lower ink removal efficiencies may negatively impact on brightness gain. Without the formation of a stable foam, floated ink particles tend to recirculate through the mixing cell, decreasing ink removal efficiency. With weir overflow systems, secondary flotation is necessary to control fibre losses and minimize sludge handling, as is the case at Avenor. Proper foam control requires control of the flotation cell weir heights, which are stabilized by maintaining a constant inventory across the flotation cells. Avenor has experienced problems with foam stability and fibre losses as a result of efforts to control flotation stock consistency. In order to control stock consistency, ratio control was used to adjust the flow of grey water dilution in ratio with the total production rate. Consequently, any change in production rate immediately resulted in a change in the total flowrate entering the first flotation cell, which in turn upset the level controls and rejects rate across the flotation cells. Additionally, poor consistency control from the retention chest and coarse screen consistency control loops resulted in continuous fluctuations in the flowrate entering the flotation cells, even during periods of constant plant production. As a consequence flotation stock losses increased to unacceptable levels. This problem was subsequently corrected by maintaining a constant total flow into the flotation cells regardless of production rate. The addition of grey water at the flotation inlet is now controlled with reference to the total flow entering the flotation cells to maintain a constant inlet flowrate of approximately 18500 L/min. As mentioned earlier, this causes flotation inlet stock consistency to vary between 0.9%-1.7% when the production rate changes from 250 to 450 tons/day [17].

Flotation efficiency remains constant between pH 6-9, above which it begins to fall. Optimal pH is a function of the type of chemicals used and fatty acid soaps requiring alkaline conditions for solubility. Control of flotation pH is achieved by feedback controlled addition of

sodium hydroxide prior to flotation. Flotation temperature is controlled through the grey water chest temperature control system, discussed previously in Section 1.1, which regulates grey water temperature for use throughout the plant. Optimal flotation temperatures are between 40-45 °C, while it has been suggested that flotation efficiency decreases at higher temperatures [2].

Control of the air to stock ratio also effects flotation efficiency. Higher air flow increases the number of air bubbles and hence the probability of collision between ink and bubble. In standard flotation cells the air to stock mass ratio increases to 150% or more depending on the number of cells. Higher air flowrate also increases turbulence and shear stresses, resulting in rapid separation of ink particle from air bubbles, leading to poorer flotation efficiency [18]. To achieve uniform aeration of pulp, the flotation cell design at Avenor operates with a constant volumetric air flow. The reduction in stock flow between each flotation cell, caused by stock rejects, is compensated for by recirculating pulp back to the prior flotation cell. The increasing stock recirculation in each subsequent cell, set by the weir heights separating adjoining cells, ensures a constant air to stock ratio in each cell. Level disturbances between flotation cells, caused by variations in the feed flowrate to the flotation cells, result in changing recirculation rates within the cells and upset the air to stock ratio. Such level control upsets, associated with changing flotation inlet flowrates, were responsible for Avenor's decision to control the total flotation feed flowrate, as mentioned earlier.

Addition of fatty acid soaps increases ink collector efficiency and fibre losses. Alkyl polyglycol ethers adsorb on calcium soap and ink particles, making them hydrophilic and resistant to flotation above concentrations of 5 mg/l [2]. Consequently, chemical dosage control is required for surfactant addition. Bentonite and polymer surfactant addition during clarification are controlled in ratio to the total clarifier inlet flowrate.

Paper age can also have a significant impact on pulp brightness gain, causing marked reduction in deinked pulp final brightness, and increasing the residual ink particle concentration on pulp by up to 30% [6]. While paper age cannot be controlled by flotation, its impact on ink removal efficiency during flotation has been observed. In general, the opportunity to reduce the age of waste paper for recycling operations will improve both pulp quality and yield.

Currently there are two brightness meters installed in the recycle plant at the flotation inlet and the high density storage outlet. The brightness meter at the flotation cells is primarily used to monitor low brightness problems. In the event of low flotation cell brightness, operators can increase pulper chemical dosage or lower production rate. Poor brightness gain can also be compensated for at the high density storage tank, or recirculated to the retention chest for reprocessing.

In addition to brightness gain through flotation, post-flotation chemical addition controls are also employed for brightness control. Sodium hydrosulphite acts as a reductive bleaching agent, used in bleaching tower applications on neutral or slightly acidic de-inked stock. Hydrosulphite is used to maintain final brightness targets, by adjusting the addition dose after the bleach tower/H.D. storage tank to ensure target brightness. At Avenor, hydrosulphite addition at the high density storage outlet is controlled by measurement of the final pulp brightness. A residual chemical analyzer measures residual hydrosulphite levels to control the chemical addition. Sodium hypochlorite is used as a oxidizing agent on chemical pulps to remove colouring dyes that cannot be bleached by hydrogen peroxide or hydrosulphite [4].

1.3 Contaminant Removal and Stickies Control

1.3.1 Physical Methods of Contaminant Removal: Screening and Cleaning

Screening and cleaning systems function to separate fibrous material from contaminants based on physical differences in size, shape or density. Basket and rotor screens are commonly used.

Standard screening systems include cascade, forward feed and series forward feed, as shown in Figure 1.3. The feed forward system avoids the recirculation of contaminants, which occurs in cascade systems. Because the accepts of the second stage are carried forward, screening capacity is increased, but at the cost of reduced contaminant removal. Avenor employs a feed forward system for coarse screening.

The most significant impact on overall screening efficiency is typically the final stage. If the final stage fails to reject a significant portion of the contaminants, they will continue to recirculate until they are reduced in size and fed forward in the accepts stream. Other studies conclude that a lower rejects rate in the final screening stage is necessary to limit fibre losses, while the reject rate in the primary stage should be as high as possible [2]. The optimal reject rate requires a balance between these factors.

The rotor action in screening serves to a) provide a pressure pulse which periodically clears the fibre mat formed on the screen; b) fluidizes the stock allowing better separation between fibre and contaminant.

Screening depends on a number of variables, including: [2]

- a) Stock Consistency
- b) Velocity through the screen basket opening
- c) Size and shape of contaminants
- d) Stock Temperature
- e) Screen basket design including slot shape and size, width between slots and profile
- f) Rotor speed, shape and distance from screen plate
- g) Power input and differential pressure between feed and accepts
- h) Reject/Feed ratio based on mass and volume flow

Screening systems control typically consists of the following configuration:

1. Feed pressure is controlled by feedback to a variable speed feed pump or control valve; feed pressure must be kept sufficiently high to ensure screen runnability.
2. Pressure differential control between feed and accepts prevents screen blockage. If the pressure differential exceeds set point, the accept valve closes, allowing the screen mat to be cleared into the rejects stream by the periodic rotor pressure pulses. When the rejects pressure equals the feed pressure, the accepts valve opens to resume normal operation. Rejects valve

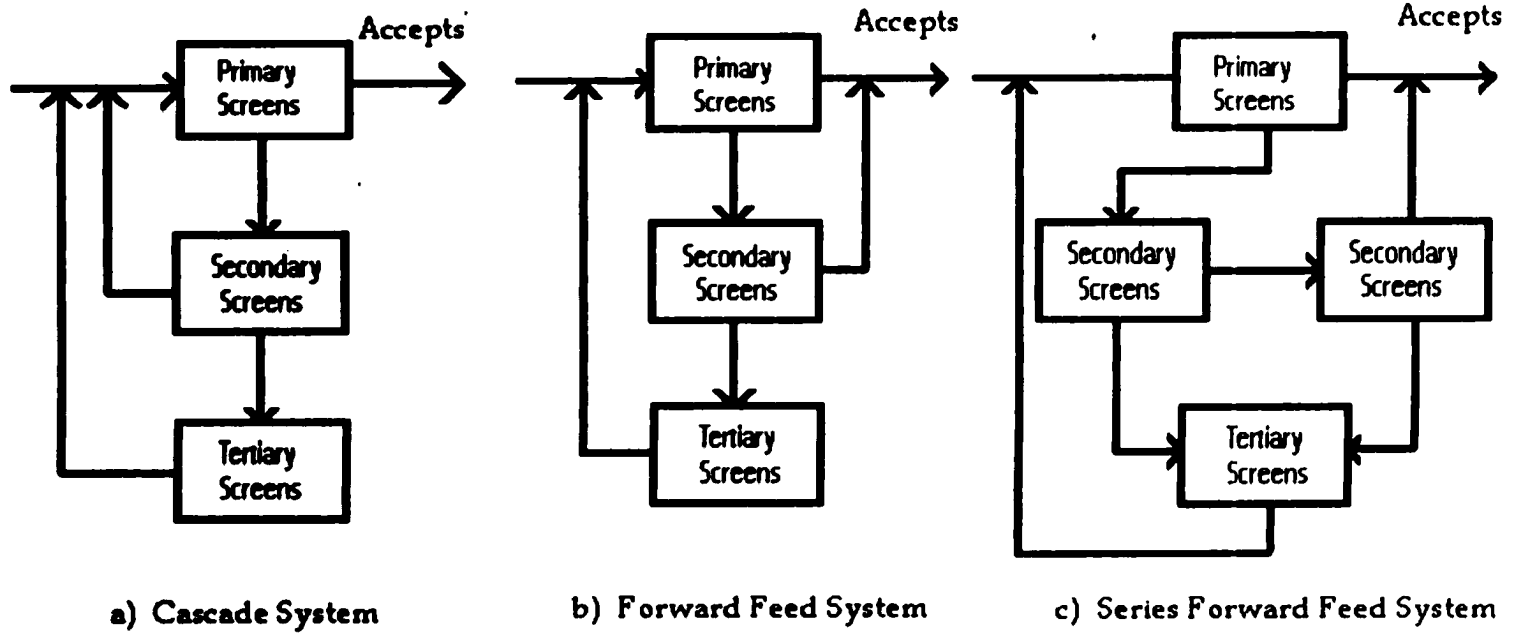

Figure 1.3 Standard Screening Configurations

blockage is monitored by a flow meter, which adjusts the rejects valve position to maintain a constant rejects rate. Figure 1.4 outlines a standard pressure screen control system. Coarse screen slot sizes are 1-2mm, while fine screen slots have slot sizes of 0.1-0.4mm.

Coarse screening control at Avenor employs a two stage supply side configuration, with primary and secondary coarse screen feed tank levels controlled by manipulating screen throughput through the screen accepts valve position. Increases in feed tank inventories are handled by increasing coarse screen throughput.

The forward feed screening system avoids recirculation of contaminants, and allows for greater system capacity. The secondary screen reject rate is under flow control, and normally remains constant. Primary and Secondary screen consistency control operates under feedback control, with the measured accepts consistency used to set the primary screen inlet dilution valve position.

Forward and Reverse Cleaner Systems

Mechanical cleaners achieve particle separation on the basis of density differences between pulp and contaminants. High density, high consistency (2-6%) cleaners remove particles with a high specific gravity, such as staples, grit and glass. These cleaners appear immediately after the pulping stage. Due to the large size of debris from the pulping state, the inlet diameter is typically 150-400mm, compared with diameters of 60-150 mm for forward and reverse cleaners. Lower diameter, lower consistency and higher pressure drop will maximize efficiency.

Forward cleaners remove small contaminants with specific gravity greater than 1.0, including adhesives, sand, and some inks. The feed consistency is between 0.1-0.8%. The accepts consistency is lower than the feed. Reverse cleaners remove components with specific gravities of less than 1.0, including waxes, adhesives and plastics. The consistency of the accepts stream is higher than the feed.

Variables controlling cleaning efficiency include a) particle size, shape, density and surface roughness; b) cleaner diameter; c) pressure drop across cleaners; d) feed to reject mass and volume flow ratios; e) consistency;

A measure of the cleaning efficiency is the 'cleaning index', defined as $I = G \cdot T / D$ where G is the centripetal acceleration, T is the residence time and D is the cleaner head diameter. Smaller diameters (60mm), higher pressure drop (206 to 620 kPa) and consistencies in the range 1.4-1.8% give optimal efficiency. The volumetric reject rate is proportional to the pressure ratio $P_a / (P_r + P_f)$ where P_a , P_r and P_f are the accepts, rejects and feed pressures. Optimal cleaning efficiency occurs with reject/feed ratio of 15-30% [2].

Control of cleaning efficiency requires high pressure drop (200-250 kPa). Control systems for forward/reverse cleaners control feed to accepts pressure drop by throttling the feed valve. As shown in Figure 1.0, the forward and reverse cleaning stages are configured as five and three stage cascade systems respectively, operating on a constant volumetric flowrate. All cleaner standpipes are gravity fed from the grey water chest to prevent cleaner cavitation, while standpipe pumps operate as constant pressure sources. The deaeration tank outlet pump speed is regulated by the deaeration tank level, and sets the supply to the forward cleaning system. Feed,

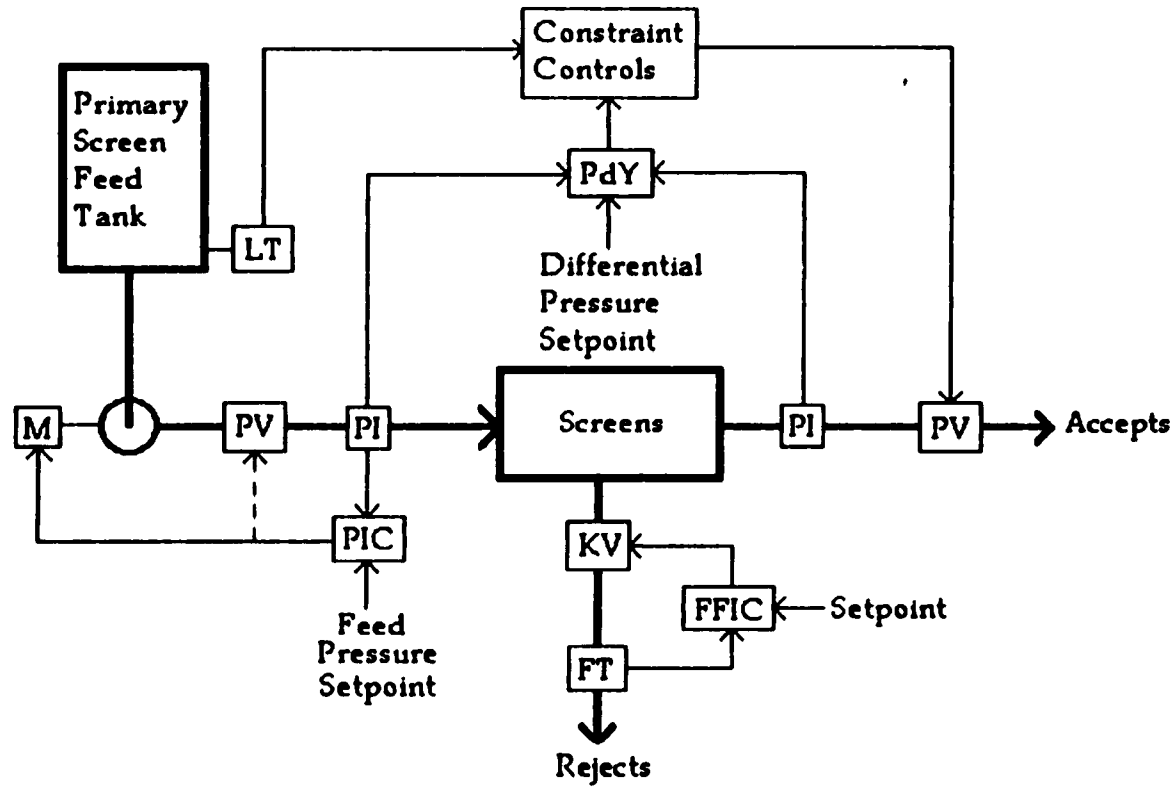

Figure 1.4 Standard Pressure Screen Controls

accept and reject pressure transmitters on all cleaner lines activate high and low pressure alerts, while differential pressure alerts also monitor the pressure drop between the feed and accepts line. High and low pressure alerts require manual intervention to correct.

Fine screening control employs a three stage, modified forward feed system. The primary and secondary screens accepts are fed forward, while tertiary accepts recirculate to the secondary screens feed tank. Pressure transmitters on the feed and accepts streams control the differential pressure across the screens by feedback regulation of the feed stream flow valve position. The screen reject rates are set on flow control, and remain constant.

The screening system is supply driven, with primary, secondary and tertiary fine screen feed tank level controls manipulating their respective accepts flow valve position to control screen throughput.

1.3.2 Chemical Methods of Contaminant Removal: Stickies Control

The chemical composition of recycle mill contaminants is complex; typical components found in deinking mill wastepaper is summarized in Table 1.3 [2]. These chemical contaminants or 'stickies' are produced in two ways: by direct breakdown or adhesives on wastepaper, and from chemical interaction. Direct breakdown occurs during pulping when adhesives broken up, and during contact with impellers and screens. Examples of chemical interaction include ethylene vinyl acetate, which is not tacky at mill temperatures, but becomes sticky and flexible by the absorption of mineral oils, fatty acids and phenol sulphates present in the system.

The adhesive properties of stickies are a function of their surface energy, surface roughness and cleanliness. The lower the surface energy of a particle compared to other surfaces, the better the particle will wet and adhere to the surface. Fatty acids reduce the surface energy of particles, increasing the adhesive properties of particles [2]. High pulping pH also increases stickies formation and deposition; the pH can be raised after pulping without increasing stickies [19].

Calcium ions affect the deposition behaviour of many stickies. Increasing water hardness from 0 to 30 ppm CaCO_3 decreases sticky deposition by 70%, and doubles the average sticky particle size. This effect is believed to be due to the action of calcium ions in neutralising negatively charged sticky particles, allowing them to agglomerate. The reduction in sticky surface area, sticky surface charge and changes in particle hydrodynamics are all factors which reduce sticky affinity for polyester fabrics. Another suggested explanation is that calcium ions cross-link acidic groups present in stickies, reducing tack [10]. In conjunction with flotation hardness control, calcium chloride is added to stock prior to flotation.

Strategies for handling and reducing stickies include screening, dispersion and chemical application. The use of screening systems which use feed forward of the primary and secondary stage accepts rather than a cascade system. This prevents the breakdown of stickies which occurs during repeated recirculation of stock within the cascade system. The same screen design and

Table 1.3 Chemical Components In Stickies

Adhesives

Styrene-butadiene copolymers
Vinyl Acrylates
Polyisoprene
Polybutadiene
Natural Rubber

Hot Melts

Ethylene Vinyl Acetate
Polyethylene
Wax
Rosin esters
Polyterpene resins
Hydrocarbon resins

size should be used in both stages. Slotted fine screens of size 0.15-0.25mm are more effective than hole screens. Optimal stickies removal efficiencies are obtained with the highest possible consistency compatible with the screen slot width [2].

Mechanical dispersion reduce the size of stickies, allowing them to blend into the fibre mat, thereby improving paper quality by removing large, unsightly specks. Pulp is dispersed at 30% consistency after thickening on the twin-wire press.

Zirconium salts react with hydroxyl groups present on the surface of stickies, forming a zirconium complex over the surface which detackifies the particle. Zirconium is most effective with acrylate and ethylene vinyl acetate based adhesives.

Non-ionic surfactants disperse stickies by forming a steric barrier around the sticky particle. The hydrophobic moiety on the surfactant absorbs into the sticky, while the hydrophilic end remains in solution surrounded by a layer of adsorbed water molecules, preventing deposition. The deinking response is directly related to the number of ethoxylate units in the surfactant molecule. Anionic surfactants prevent agglomeration by surface charge repulsion. Only ethoxylate derivative surfactants have been effective in reducing tackiness [2].

Talc consists of alternating layers of magnesium and silica sheets. The surface of talc particles are hydrophobic, while the edges are hydrophilic. Due to hydrophobic interaction with sticky surfaces, talc adsorbs on sticky particles, forming a steric barrier which reduces tackiness. Although used for pitch control, adsorption of pitch components on talc is less than 20%, hence talc adsorption on stickies is predominantly responsible for detackification. Talc will only attach to stickies that are tacky at head box temperatures; substances with tacky properties only at dryer temperatures will not be protected. Talc has poor resistance to shear forces, and can detach from sticky surfaces in shear sensitive areas such as pumps and refiners. This detachment can lead to agglomeration of stickies and machine deposition problems. Talc is typically added later in the de-ink process, at concentrations of 1.0%-3.0 % odp [5]. The addition of talc at 1.5% and bentonite at 0.5% odp, remain the major chemicals used for stickies control by Avenor.

Other means for stickies control include absorptive fillers, such as silicates and calcined kaolin, which absorb organic species such as fatty acids and soaps associated with stickies activation thereby helping to prevent stickies formation and deposition.

1.4 Clarification and Grey Water Inventory Control

Clarification is used to remove ink, dirt, fillers and fines accumulated in the grey water loop and that cannot be removed by other methods. Removal of suspended solids is necessary for the operation of high pressure showers, to reduce scaling and to prevent accumulation and redeposition of inks and dirt within the system.

Clarifier influent is composed a wide range of colloidal particles including hydrophobic inks, proteins, and organics. Suspended particles repel each other, primarily because of surface charges acquired through ionization or absorption of charged particles. Similarly charged ions repel each other, while oppositely charged ions attach to charged surfaces forming a stable electric double layer. Hydrophilic particles are dispersed by the formation of an electrical double layer and by surface bound water molecules, through which ions cannot penetrate.

The stability of a colloidal dispersion depends on the balance of attractive and repulsive forces between particles. Attractive forces include Van der Waals forces, while repulsive forces include similarly charged electrical double layers and particle hydrate layers. The adsorption of counter ions reduces the repulsive forces between colloidal particles, increasing the tendency towards aggregation. Highly charged ions are most effective: the relative coagulating ability of Na^+ , Ca^{++} and Al^{+++} is 1:100:1000 [9].

Factors favouring coagulation include: a) lower particle size; b) reducing the particle surface potential; c) increasing the ionic strength of solution; d) increasing temperature e) increasing colloidal concentration.

In many clarifiers, a dual polymer system is used consisting of a high charge-low molecular weight cationic polymer and a high molecular weight anionic flocculant. The cationic polymer functions to reduce anionic particle surface charges; examples include polyquaternary amines such as polydiallyldimethyl ammonium chloride. The anionic flocculant functions to increase agglomeration size: polyacrylamide is commonly used. Typical dosages are 10-40ppm cationic polymer and 3-5 ppm for anionic flocculant [20].

Bentonite, a modified clay with an enormous surface area, absorbs anionic material such as inks and fines and is often used as a replacement for the cationic polymer [20].

Clarifier controls at Avenor are modest, consisting of high and low turbidity monitoring alarms on the clarifier accept stream and flow controlled addition of bentonite and polymer. Bentonite and polymer feed flows are set by ratio to the total clarifier feed flow. Excess addition of cationic polymer must be avoided, as the potential for surface charge reversal on colloidal particles can again stabilize the dispersion. Clarifier control is monitored by turbidity measurement on the clarified accepts stream. Methods to monitor the total solution charge have been proposed as a means to control the addition rate of cationic polymer, but remain limited by the need to determine the polarity of charge on the suspended particles [10].

Grey water inventory is maintained through the grey water chest, which supplies dilution water for pulping, screening, centrifugal cleaners, consistency control and showers. Grey water chest level is regulated by addition of fresh water and central white water tank makeup water. Process dilution water is recirculated to the grey water chest during the thickening stage at the disc filter and twin-wire press. Filtrate from the disc filter feeds the clear and cloudy grey water chests; twin wire press filtrate feeds the cloudy grey water tank.

The control of grey water chemistry is a concern, primarily because the addition of paper machine white water for grey water chest level control impacts on grey water chemistry, by changing the composition of process grey water. Level control upsets in the grey water chest cause changes to the addition of makeup water, resulting in sudden changes to the composition of grey water in the retention chest. In order to minimize sudden changes to makeup water flow, a grey water control strategy was developed, as discussed further in Chapter 5.0.

Level controls on the clear grey water chest control makeup water from the fresh water header upon low level alert. Clear grey water overflow returns to the grey water chest for reuse, while clear grey water tank underflow forwards to the grey water screens, which in turn feeds back to the grey water chest and the filtered grey water chest. Clear grey water tank underflow is controlled by the level controller on the filtered grey water tank. Filtered grey water supplies shower water throughout the mill.

The cloudy grey water tank acts as inventory for the flotation clarifier. The tank outlet stream is under flow control to a variable speed pump. Cloudy grey water tank level controls detect high and low level alerts, adding makeup water from the grey water chest in response to low inventory and sewerage cloudy grey water tank overflow.

Flotation clarifier accepts are returned to the grey water chest for reuse. Clarifier rejects, along with screens and cleaner rejects exit the grey water system and feed the sludge chest. Bentonite, polymer and dissolved air are added to the clarifier feed under ratio control with respect to the total clarifier feed flow. A turbidity meter on the clarifier accepts line detects low and high turbidity levels as an operator alert.

Dilution water from the paper machine white water dilution tank is added to the bleach tower MC standpipe, high density storage tank and disc filter MC standpipe. Except during periods of pulp recirculation, this P.M. white water leaves the plant with the final pulp.

1.5 The Impact of Recycling on Pulp Quality

The quality of recycled pulp is dependent on a variety of factors, including waste paper type, prior manufacture and treatment of waste papers, and changes due to the recycling operation itself. Recycled chemical pulps show reduced breaking length, burst and fold. The primary cause of these changes is the reduced bonding ability of fibres, associated with loss of fibre wall swelling. Water retention values are directly correlated to tensile strength, indicating the importance of fibre swelling. In the initially swollen state, the fibre wall consists of multiple lamellae, which allow for a flexible fibre surface and intimate fibre-fibre bonding during sheet formation and drying. During drying, hydrogen bonding and surface tension bring adjacent fibre walls together, forming a tightly bonded structure. During repulping, the tightly bonded fibres do not completely re-swell, resulting in stiffer and less conformable fibres. Consequently, a weaker and bulkier sheet forms because fibres do not align for optimal bonding [20].

In contrast to chemical pulps, mechanical pulps show small increases in strength and density upon recycling. This behaviour is explained by the fact that because mechanical fibres are already extensively delaminated, drying does not effect inter-fibre bonding. However, the increased bonding strength is a consequence of fibre flattening and greater flexibility gained during sheet formation and drying. The strong correlation between breaking length and sheet density, and the significant increase in the number of flattened fibres observed in recycled sheets, are both taken as evidence for this mechanism [21].

Changes in fibre properties during virgin paper making also effect the recycle potential of waste paper. The greater the degree of refining on virgin chemical pulps, the greater the change in pulp quality after recycling. Refining delaminates the fibre wall to a larger extent than in unrefined pulps, which upon drying produces a tightly bound fibre that does not fully reswell when repulped. Refining also increases the number of fines and reduces fibre length, both of which reduce recycled pulp quality [22]. Drying conditions during chemical pulp manufacture influence recycle potential. Higher drying temperatures significantly reduce water retention values on chemical pulps, resulting in a poorer quality sheet upon recycling. The degree of fibre wall hornification accounts for the reduce recycle potential. Heavier calendering, associated with greater compression and damage to fibres, results in lower water retention values, fibre length and fibre strength, while improving the gloss and roughness of the final product [22]. Chemical conditions during initial sheet formation also influence the degree of fibre swelling during repulping. Unbleached pulps dried under acidic conditions show less swelling than similar pulps under alkaline conditions, due to the high acid group content of unbleached pulp and the change in the ionic state of the fibre with pH [23].

Recycled pulp generally shows reduced strength, optical properties and freeness when compared to virgin pulp with the same degree of refining. Mechanical action at consistencies above 8% results in curl and microcompression of fibres producing a weaker and bulkier pulp. These conditions are present during high consistency pulping, bleaching, and dispersion operations associated with recycling.

The use of sodium hydroxide increases pulp strength, due to the increased fibre swelling and resultant better bonding fibre. The presence of residual surfactants, used during flotation, can lower fibre surface tension during sheet formation, resulting in lower paper strength. Refining also

improves fibre bonding ability, by delaminating the fibre wall to reverse the effects of hornification from prior drying stages. Delamination of the fibre wall improves swelling and inter-fibre bonding, thereby increasing pulp strength. Refining increases the number of fines and reduces fibre length. However, the lower freeness of refined pulps impacts on paper machine production: by refining recycled pulp to give the same strength as virgin pulp, significant reductions in drainage rate are observed (associated with higher fines level), which limit the production capacity of paper machine operations [22].

1.6 Implications for Control at Avenor, Thunder Bay

1.6.1 Pulping Control: Optimization of Pulper Conditions

In order to minimize process costs and maximize ink removal efficiency and brightness gain, greater knowledge on the effect of changing pulping conditions on overall brightness gain is necessary. In particular, the problem of significant brightness variation at the flotation cell inlet is a concern. The brightness continually cycles over periods of 4-6 hours with brightness changes of up to 5.0 ISO units. No major process variable was identified with a similar period. In order to correct for low brightness, production must be lowered and higher chemical dosages used in the pulper. Increasing peroxide and caustic dosages can be used to restore brightness during periods of poor incoming wastepaper quality. This requires assessing wastepaper quality in terms of age and contaminant levels. At peroxide levels of 0.8% odp, increasing caustic dosage from 0.7% odp to 1.1% odp produced no change in brightness gain, but reduced pulp ERIC number (Evaluation of Residual Ink Content) from 275 ppm to 230 ppm. Aged paper reduces brightness gain by up to 3.5 ISO and increases ERIC number by 90 ppm [6]. Currently operators attempt to identify and process low quality paper all at once, compensating for poor quality with higher chemical dosages. While this cannot be used as feedback for brightness control, it does enable a degree of feed forward compensation.

Low brightness at the flotation cell inlet is also correlated with low final brightness, and requires downstream compensation to achieve acceptable pulp quality. Final brightness targets are currently achieved by controlled addition of sodium hydrosulphite after high density storage. In the event of unacceptable brightness gain across the flotation cells, pulp is recirculated to the retention chest for reprocessing.

Potential sources for the cyclic variation in brightness were investigated to determine the impact of pulping conditions on flotation inlet brightness variation. Although pulper chemistry is under DCS control, variations in batch to batch chemical addition varies by up to 10%, while variations in percent magazine per batch often vary significantly. This variation in chemical dosage per ton is primarily due to the regular variation in batch to batch tonnage, which typically varies by up to 15% of the batch setpoint during normal operation. With chemical addition proceeding while paper addition to the pulper continues, differences in batch tonnage effect the chemical dosage on pulp each batch.

The relationship between flotation inlet brightness and peroxide, caustic, DTPA, silicate, percent magazine, pH and production rate were investigated to determine their relationship to brightness variation. The results, discussed in Chapter 3.0, have not demonstrated a strong correlation between any of these variables and low brightness. Rather than investigating production variations by process monitoring, an area that offers further opportunity for pulper optimization and control involves the use of fractional factorial designs to identify main and interaction effects between variables [24]. Because each pulping batch offers the opportunity to conduct a separate experimental run, an automated factorial design algorithm would allow continuous investigation of up to 6 variables at once. Investigation the main effects and

interactions effects for 4 variables could be done in 16 batches, or half a day. This time period is reasonable for investigating day to day quality control. Experimentation in this manner would facilitate a continuous learning environment in which the effects of variables on plant operation can be constantly tested.

Avenor has begun investigating the effects of 11 pulper variables to determine what effects contribute significantly to brightness gain. These factors can then be further investigated to better define the optimal operating point. Factors being investigated include sodium hydroxide, hydrogen peroxide, sodium silicate, DTPA, slushing time, pulping consistency, impeller speed, pH, newsprint/magazine ratio, wastepaper age and water hardness.

1.6.2 Pulper Discharge Consistency Controls

The consistency of pulp fed to the retention chest during phase 5 discharge is poorly controlled. During pulper discharge, stock is diluted from 10% to 4.5% for addition to the retention chest. As shown in Figure 1.5, the pulper empties with grey water dilution added to the pulper (FT115) and discharge line (FT123). As the pulper drains, the consistency of the pulp changes from the addition of dilution water to the pulper. This results in high consistency stock entering the retention chest at the beginning of pulper discharge and low consistency stock entering towards the end of the phase. Although the total dilution water added satisfies the overall target of 4.5% consistency pulp addition to the retention chest, the local variation in pulp consistency creates problems during high density cleaner dilution. Due to its greater density, high consistency pulp preferentially sinks to the bottom of the retention chest producing poor mixing and variable retention times for pulp in the retention chest. The resulting variations retention chest consistency require excessive valve action during dilution stages to accommodate the consistency variations. These consistency variations appear throughout the cleaning and flotation stages downstream [8]. It has been suggested that these consistency variations may be responsible for an artificial brightness effect measured at the flotation cell inlet. An examination of the correlation between flotation inlet consistency and brightness variation did not support this conclusion.

Variable residence times within the retention chest may also be responsible, in part, for brightness variations at the flotation inlet. Brightness reversion can occur from alkali darkening if peroxide levels drop below 0.6% odp [4]. A bleaching effect has been also been observed in the retention chest if peroxide levels are maintained high enough to prevent alkali darkening [25]. Variable residence times in the retention will also produce this effect. However, measurement of the peroxide levels at the flotation cell inlet does not show low peroxide levels, indicating that alkali darkening is not responsible for the brightness variation. Poor consistency control during discharge also impacts on retention chest consistency control and downstream consistency loops, as discussed in Chapter 4, which discusses the implementation of a feed-forward consistency control block to control the phase 5 discharge consistency.

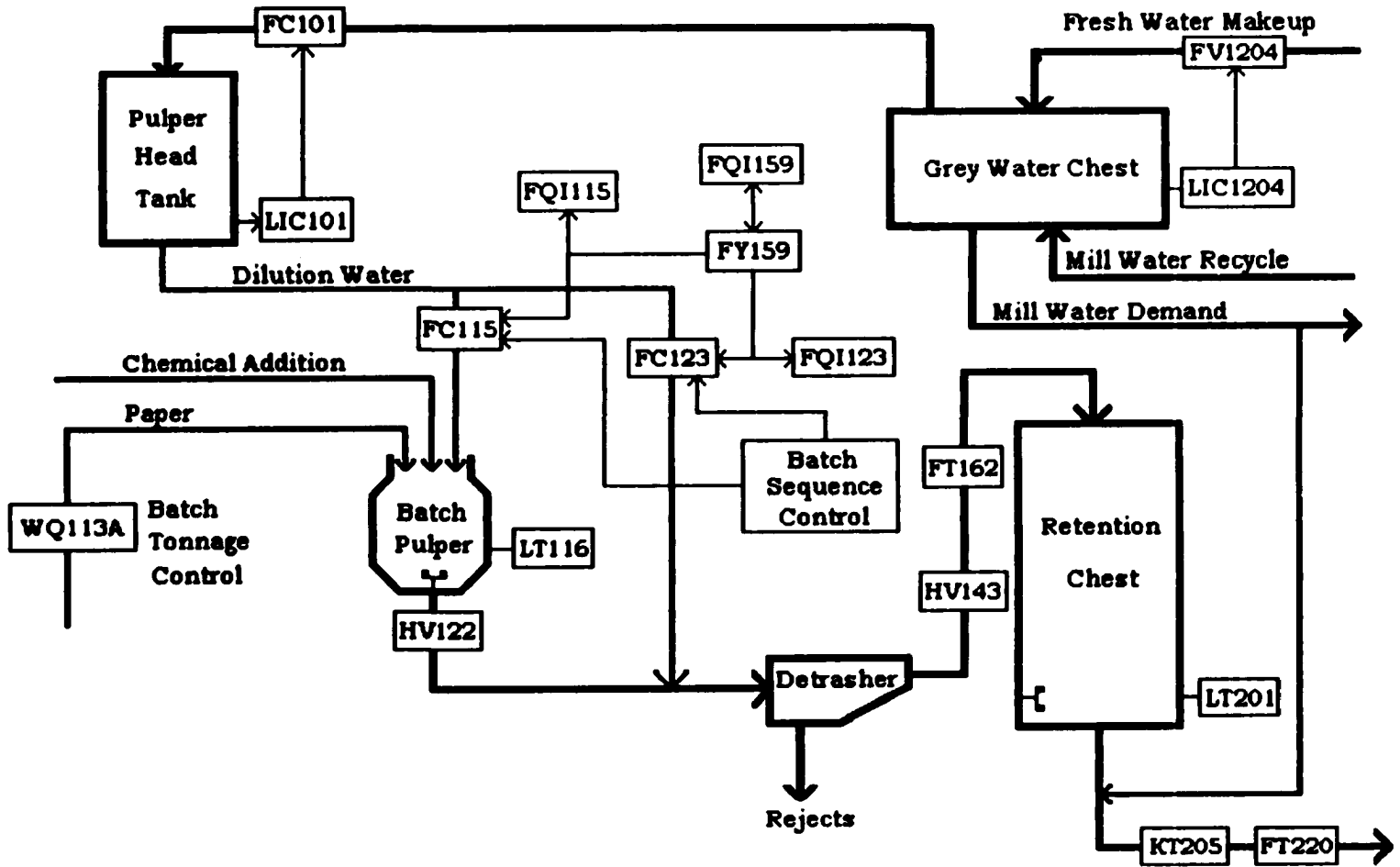

Figure 1.5 Grey Water and Pulping Process Flowsheet

1.6.3 Flotation Control

Flotation control include brightness monitoring, inlet pH control, calcium chloride and soap addition. Flotation inlet brightness is monitored to detect low quality pulp. Flotation cell brightness was discussed in Section 1.6.2. Inlet pH operates under feedback control, with sodium hydroxide added to maintain a setpoint pH of 9.5. Inlet consistency was formerly under ratio control, with primary inlet dilution water in ratio to the primary screens accepts flowrate to give a consistency of 1.1%. However, level control problems caused by varying flotation inlet flowrates has required the maintenance of a constant flow rate to the flotation cells in order to control stock losses and foam stability. As discussed in Section 1.2, this prevents control of stock consistency feeding the retention chest. Calcium chloride addition is currently set in ratio to the production rate (5.5%) to give a concentration of 200 ppm, while soap addition is similarly supplied by ratio to production (0.6%).

Due to the variable quality of incoming wastepaper and low inlet brightness, there is a potential to improve the calcium chloride soap and pH levels to achieve an optimal brightness gain across the flotation cells. Although currently there is only one brightness meter on the flotation inlet, there are plans in the future to add a second brightness meter on the final flotation cell. With this addition it will be possible to use feedback control on the flotation cells to achieve the optimal process conditions. An on-line two level factorial design procedure could be automated to vary the calcium chloride-soap concentrations in search of the optimal conditions for brightness gain. This controller would continual perform a 5 point experiment to find the optimum calcium chloride-soap levels. Each experimental cycle could be run in approximately 20 minutes. The controller would be constrained for maximum and minimum allowable chemical dosages, and would be designed to vary the step size between experimental points to produce small but detectable changes in the control variable. The significant advantage of this method over conventional setpoint controllers is the opportunity it provides for gathering process knowledge regarding the effects of process variables, the interaction effects between variables their impact on quality targets.

Chapter 2

Talc Addition Control of a Screw Conveyor Metering System

2.0 Introduction

Talc is added to recycled stock for pitch and stickies control, primarily to prevent the agglomeration of contaminants on the paper machines where they damage paper machine webs and produce unacceptable product. Talc consists of alternating layers of magnesium and silica sheets. The surface of talc particles are hydrophobic, while the edges are hydrophilic. Due to hydrophobic interaction with sticky surfaces, talc absorbs on sticky particles, forming a steric barrier which reduces tackiness. Although used for pitch control, adsorption of pitch components on talc is less than 20%, and talc adsorption on stickies is predominantly responsible for detackification. Talc is typically added later in the de-ink process, at concentrations of 1.0%-3.0 % odp.

It is also necessary to avoid over-addition of talc, as high talc concentrations produce agglomeration of talc-stickies complexes which deposit on paper machine fabrics. At Avenor, talc is added prior to dispersion at 1.5 % on odp. The possibility of adding bentonite at 0.5% per odp is also being investigated as an additional source for stickies control.

2.1 Talc Control Problem Formulation

The original control design for the talc system is shown in Figure 2.0. A 1170 kg talc bag is suspended above the talc conveyor hopper and feeds the metering screw. The talc is fed into a three cell dilution tank where it is mixed before entering the disperger. Talc slurry is fed to the disperger under flow control, with the talc slurry flow setpoint is maintained in ratio to the Twin Wire Press production rate. The dilution tank level controller manipulates mill water addition to dilution cells 1 and 3 to maintain inventory. Talc concentration is measured by a density transmitter, based on a calibrated curve relating talc concentration to slurry density. The controller manipulates the talc screw motor speed to deliver the correct amount of talc. Changes in talc concentration are also compensated for by adjusting the flow ratio setpoint between talc slurry flowrate and the TWP production flowrate.

This system was found to be unreliable for controlling talc addition rate. Operating experience demonstrated that the density transmitters were subject to drift and were unreliable for measuring talc concentration. The transmitters was subsequently shut off, and the talc addition rate controlled manually. This situation did not allow for good talc control: the operators cannot monitor the situation and generally ran the conveyor screw motor at a constant speed. Adjustments were made only during major production rate changes or if problems were noticed. In addition, the behaviour of the talc metering screw was subject to periodic change over time due to partial plugging of the screw rails. This consequently changed the relationship between motor speed and talc addition rate, requiring the operators to make regular adjustments in the motor speed to achieve proper talc addition control. The changing behaviour of the metering screw caused difficulties for the operators in determining the appropriate screw speed for a particular plant production rate, as the correct screw speed for proper talc addition tended to vary randomly over time.

Operators can only determine the effectiveness of talc addition control every 24 hours,

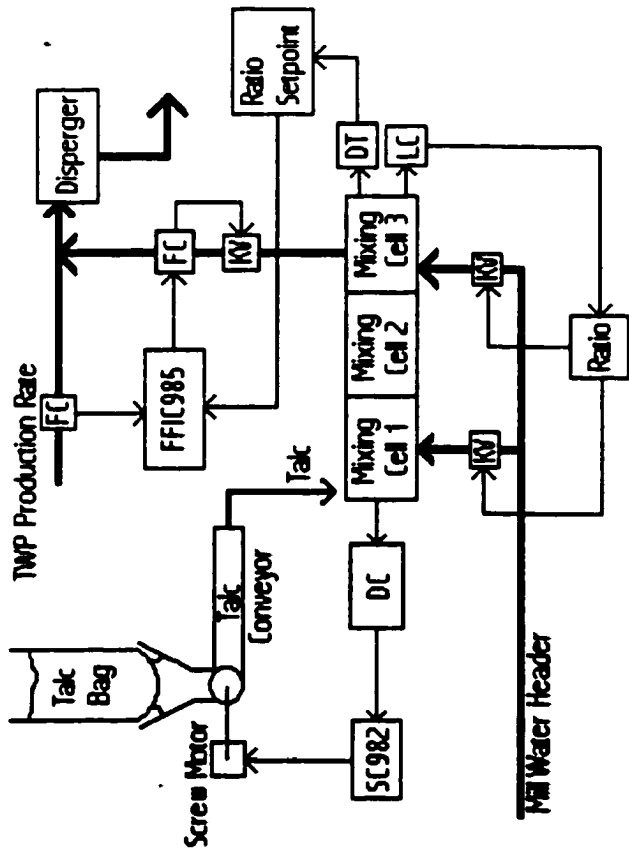

Figure 2.0 Original Talc Metering Control System

when the total talc addition and production for the day are summarized. Because of problems with the changing behaviour of the talc metering conveyor, over or under addition of talc can exceed 50% of the setpoint value during the last day before being noticed and corrected [8]. It is desirable to control the talc concentration to ensure good stickies control. Excess talc addition must also be avoided to prevent talc-stickie precipitation on paper machine webs [26], and to minimize chemical costs.

Excessive talc accumulation is a concern during stock recirculation in the recycle plant. During periods of poor post-flotation pulp quality, stock can be recirculated from the bleach tower to the retention chest for reprocessing (see Figure 2.1). This situation creates the potential for talc buildup within the plant, and requires compensation by adjusting the talc addition rate at the disperger.

The objective of the Avenor mill was therefore to develop a control system that would achieve the following goals.

- a) Automatically add the correct amount of talc to achieve a given talc/fibre ratio on pulp feeding the disperger.
- b) Develop a model to estimate the amount of talc in the pulp flow to the disperger. This model must be recalibrated each time a bag of talc is changed.
- c) Adjust the talc addition rate during recirculation to compensate for talc already present in the pulp. This requires compensating for the time delay necessary for the recirculating pulp to pass through the system and return to the talc addition point.
- d) Provide easy operator interaction with the system to:
 - i) Permit plant operators to indicate when a talc bag has been changed. This enables re-calibration of the talc screw behaviour.
 - ii) Permit plant operators to adjust the talc/fibre ratio setpoint.
 - iii) Permit plant operators to readily change talc control from supervisory to manual mode.
 - iv) Alert plant operators in the event of control system malfunction.

2.2 Control System Development and Implementation

The control system for talc addition was implemented through the Recycle Plant Distributed Control System (DCS) as an Independent Sequence Block 'RN_TALC:TALC986.s'. Figures 2.2 and 2.3 respectively show the Talc Supervisory Control System Configuration and Loop diagram for the sequence block, with signal inputs and outputs. The on-line independent Sequence Block algorithm is shown in Appendix A.

The sequence block controls the setpoint on the talc screw feed motor, SC982, to provide the correct addition rate of talc, and calculates the talc/fibre ratio after each talc bag. The talc

40

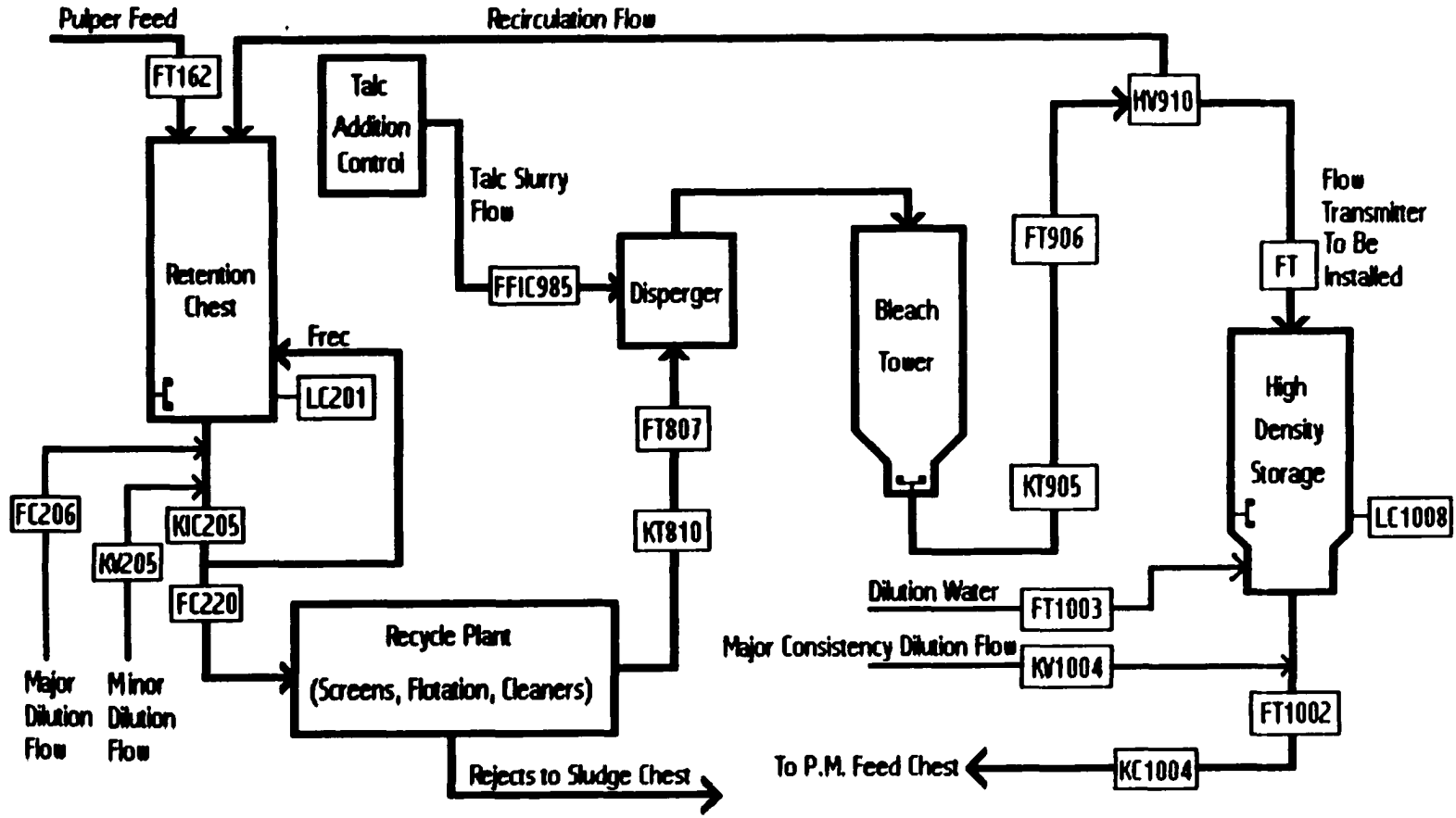

Figure 2.1 Talc Recirculation Process Flowsheet

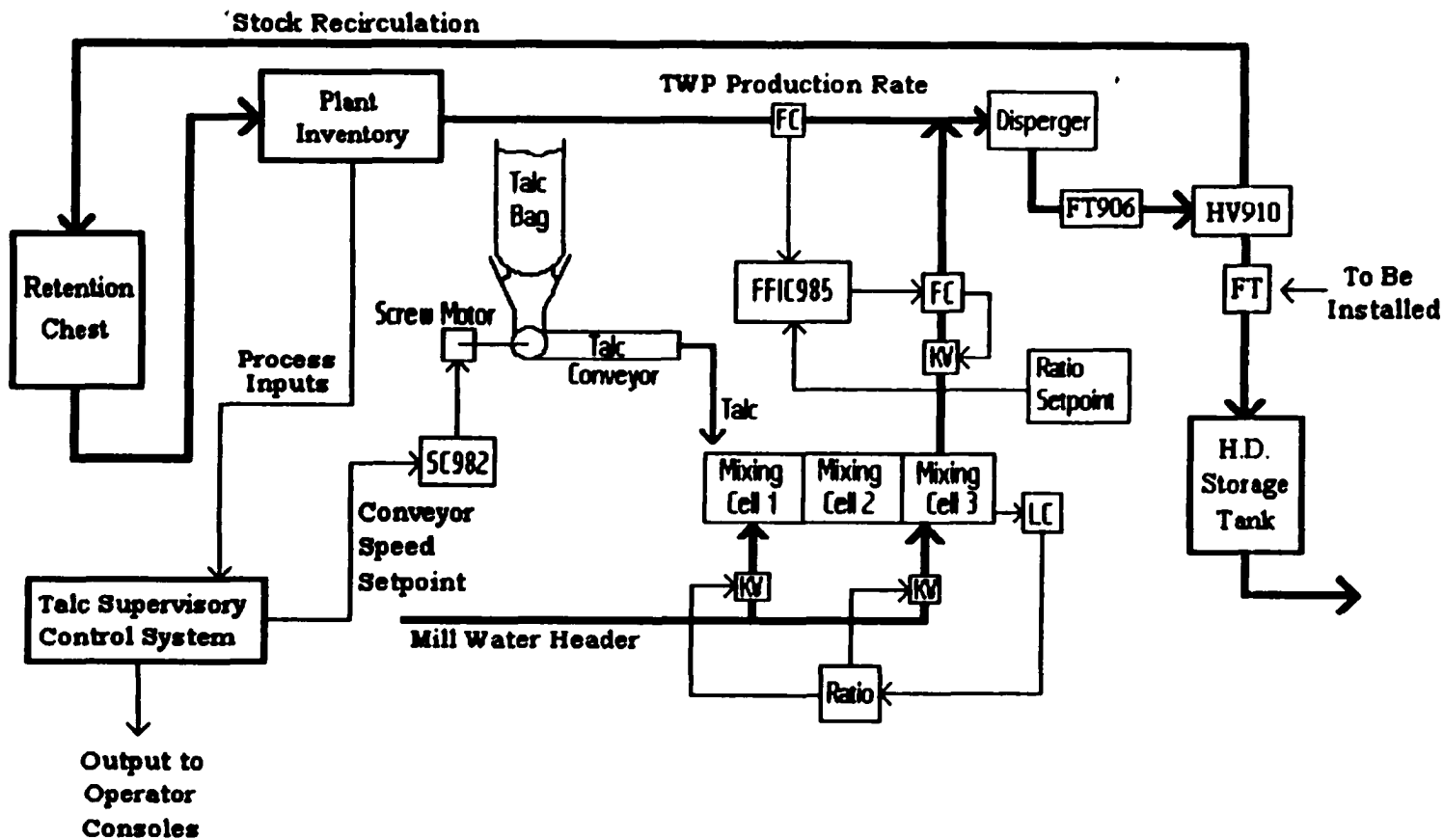
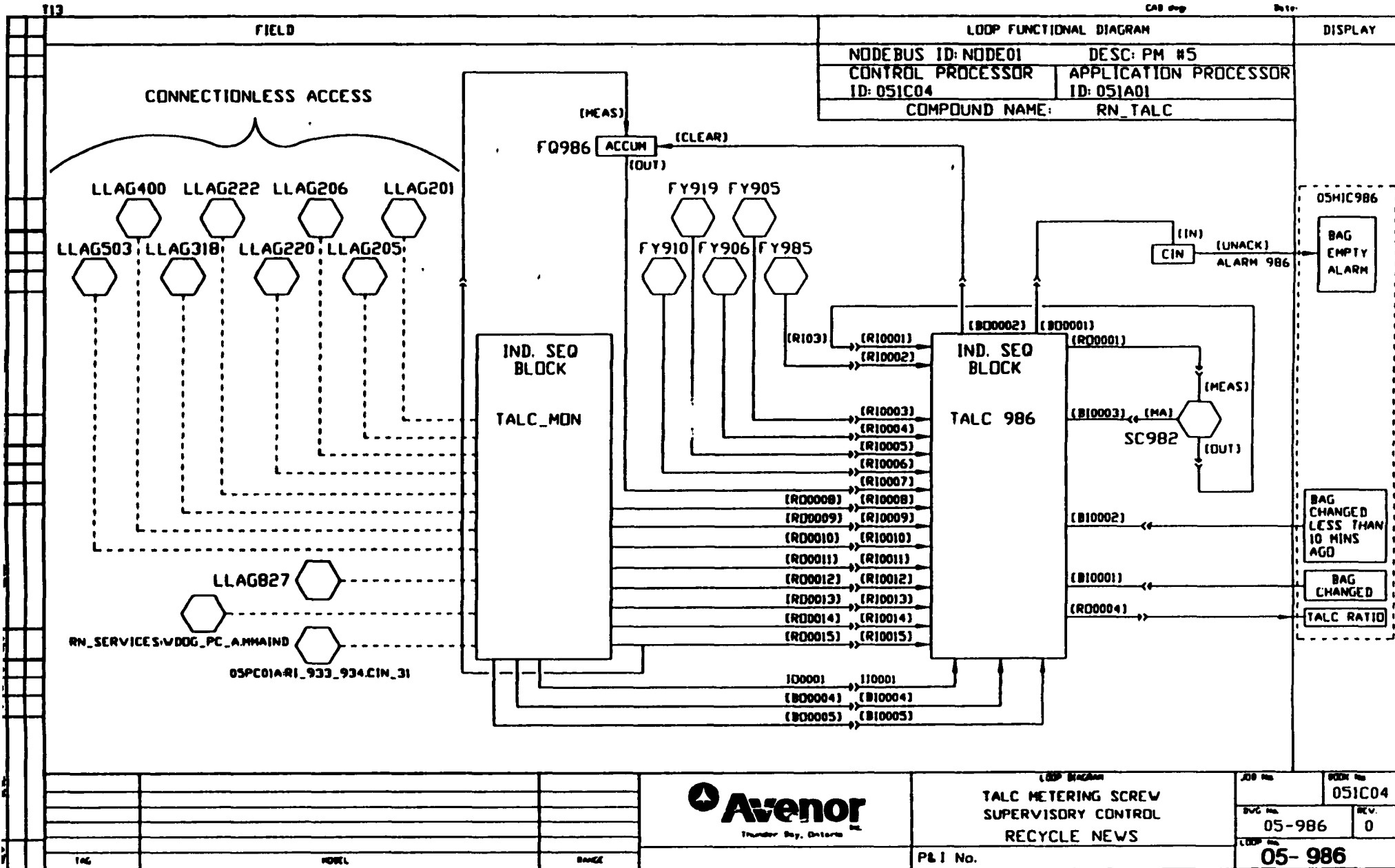

Figure 2.2 Talc Metering Conveyor Supervisory Control System

Reproduced with permission of the copyright owner. Further reproduction prohibited without permission.



LLAG827

05PC01A\RI_933_934.CIN_31

Figure 2.3 Talc Conveyor Supervisory Control System Loop Diagram



TALC METERING SCREW
SUPERVISORY CONTROL
RECYCLE NEWS

JOB No.	051C04
DWG No.	05-986
REV.	0
LOOP No.	05-986

P & I No.

slurry flow to the disperger is under flow ratio control to the twin wire press production rate.

To develop a strategy for improved talc control, the major constraint to be handled was the limited process measurements suitable for control. Variables available for measurement and control include the talc screw motor current, the production rate, and the time between talc bag changes. It was confirmed by experience that the relationship between screw motor speed and talc addition rate was linear, but tended to drift over time due to periodic partial blockage of the talc metering screw. The talc metering screw was therefore modelled by the relation:

$$\text{Talc feedrate (kg/min)} = k_1 * (\text{Talc Screw Motor Speed}) \quad (2.1)$$

The constant k_1 can only be estimated with a knowledge of the screw speed and talc addition rate. However, the only available data relating the screw speed to the talc feedrate is the time and average screw conveyor speed between consecutive changeovers of talc bags. This is a consequence of the fact that only after the complete use of one talc bag can any estimate of the amount of talc entering the system be easily obtained. The control strategy can therefore only determine the screw conveyor model parameter from the time period required to use one full talc bag.

Typically a talc bag is changed every six hours during normal production, at which time the operator must indicate a talc bag change with the new talc controls to allow the recalibration of the talc model parameter k_1 . After complete use of each talc bag, k_1 is estimated from the average screw speed and the total amount of talc added over the time period for use of one talc bag (1170 kg).

During periods of pulp recirculation, it is necessary to determine the recirculation rate of pulp returning to the retention chest in order to calculate the amount of talc recirculating in the plant. Initially this created a measurement problem as there was no direct means to measure the recirculation flow. It was therefore necessary to estimate the recirculation rate from other process measurements in the high density and retention chests. Subsequently, the recycle department decided to delay efforts to regulate the talc concentration within the plant during recirculation until the installment of a new flowmeter to allow direct measurement of the recirculation rate. This is discussed in Section 2.2.1.

The talc recirculation process flowsheet is shown in Figure 2.1. During normal operation, stock enters the dispersion unit after thickening and talc slurry addition. Talc addition is controlled to give the desired concentration of talc on pulp, currently 1.5% wt/wt on pulp. After dispersion and bleach tower storage, the pulp is fed to the high density storage as final product, or recirculated to the retention chest for reprocessing. During periods of recirculation, it is desired to calculate the amount of talc recirculating in the system, and adjust the talc addition rate prior to dispersion to maintain a talc concentration of 1.5% wt/wt on pulp.

The control strategy was implemented as an independent sequence block on the Unix based Distributed Control system in the recycle plant. The operational sequence code used for implementation is shown in Appendix A.

Figure 2.2 shows the control block configuration. The total slurry flow is under ratio control to the twin wire press production rate, while talc mixing cell level is maintained by addition of mill grey water. The supervisory controller TALC986.s controls the talc addition rate

by control of the talc screw conveyor speed. An outline of the controller algorithm is shown below.

- 1.0 a) Program Initialization: Assume an initial model for the talc metering screw conveyor of the form:

$$\text{Talc addition rate} = k_1 * \text{Screw Conveyor Speed} \quad (2.2)$$

- b) Initialize all variables for start-up.
- 2.0 Using the current model of Conveyor Screw behaviour:
- a) Measure the Pulp recirculation rate returning to the retention chest. (The calculation of this flow is discussed under Retention Chest and High Density Storage Modelling). If HV910 is closed, set the current recirculation rate to zero. From the most recent estimate of the percent talc on pulp achieved at the disperger, calculate and store the talc recirculation rate feeding the retention chest in the array TALC_RET.
Update all talc recirculation rates for the last 300 minutes stored in TALC_RET.
- b) From the current plant production rate, (calculated from FT220 and KT205), calculate the lag time for recirculating pulp to pass from the retention chest to the disperger inlet. Using the calculated lag time, look up the flowrate of talc returning to the disperger inlet with the recirculating pulp.
- c) By accounting for the current production rate and talc flowrate recirculating in the pulp, calculate the correct screw conveyor speed setpoint to achieve the desired talc addition rate and % talc/fibre ratio.
- d) Integrate the total pulp feeding the disperger (measured by the twin wire press production rate) and the actual screw speed during the current 3 minute sampling period.
- 3.0 a) If the controller is in supervisory mode (AUTO_MAN=True), output the calculated screw speed setpoint to the talc screw conveyor controls. If AUTO_MAN is False, continue monitoring the screw speed while enabling the operator to manually set the conveyor screw speed.
- 4.0 a) If BAG_CHG is true, the current talc bag inventory has being depleted and replaced with a new talc bag. If the operator has correctly recorded the current changeover time to a new talc bag (BAG_CORR=True), and correctly recorded the changeover time for the previous talc bag change (LAST_BAG=True), then the total addition of talc between the changeover times will be 1066 kg, or one

talc bag.

- b) If BAG_CORR and LAST_BAG are true, use the average conveyor speed, the total amount of talc added, to update the talc conveyor model constant k relating talc addition rate to screw speed. If either BAG_CORR or LAST_BAG are false, continue with the current model of the talc screw conveyor.
- c) From the integrated total pulp tonnage processed during the metering of the last talc bag, calculate the average talc/fibre ratio achieved. Using this estimate, update the talc recirculation flowrates stored in TALC_RET during the last talc bag cycle.

5.0 a) Wait 3.0 minutes (SMPL_TIME), then return to step 2.0.

During pulp recirculation, it is desirable to account for the possibility of talc losses in the screen and flotation rejects. Talc lost in reject streams cannot be compensated for unless talc losses can be determined. However, these losses were considered negligible because:

- a) Talc particles already attached to fibres or stickies are more likely to pass through the screening and contaminant removal systems on a second pass without being lost. Most of the reject material will have been removed during the first pass.
- b) It is more important to protect against an excess addition of talc than against low talc addition. Excess talc addition causes severe redeposition problems on paper machine fabrics, resulting in downtime and web breaks. Low talc levels can become problematic at high stickies concentrations; this was not as serious a concern as avoiding high talc concentrations in the recycle mill [27]. It was therefore decided to ignore talc losses during stock recirculation.

A controller sampling period of 3.0 minutes was determined to be adequate for the control of talc addition. Changes to talc addition are required only for production rate or talc bag changes. Plant production rate typically remains constant for several hours at a time, while talc bag changes occur every 4-6 hours. Additionally, the talc slurry tank residence time of approximately 30 minutes provides adequate talc inventory in the event of sudden production rate changes. To remove noise, process measurements were filtered through first order lag blocks with 1 minute time constants before control block sampling.

Retention Chest Modelling

A full material balance around the retention chest yields the following:

$$\frac{d}{dt}(V_{ret} * C_{ret}) = F_{pulper} * C_{pulper} + F_{rec} * KT_{905} - F_{out} * C_{ret} + F_{ret} * KT_{205} \quad (2.3)$$

- where
- 1) KT_{205} = high density cleaner inlet consistency
 - 2) C_{ret} = retention chest consistency
 - 3) F_{pulper} = pulper flowrate feeding retention chest
 - 4) F_{out} = flowrate leaving the retention chest,
 - 5) F_{ret} = recirculation flow from the H.D. cleaner outlet to the retention chest
 - 6) KT_{905} = stock consistency recirculating to the retention chest from H.D. inlet
 - 7) C_{pulper} = consistency of pulper stock feeding retention chest

The Volume in the Retention chest can be related to the tank level transmitter, but F_{out} cannot be measured: it can however be estimated from a flow balance:

$$F_{out} * C_{ret} = (FT_{220} + F_{ret}) * KT_{205} \quad (2.4)$$

which gives

$$d/dt(V_{ret} * C_{ret}) = F_{pulper} * C_{pulper} + F_{rec} * KT_{905} - FT_{220} * KT_{205} \quad (2.5)$$

The recirculation flow F_{rec} can be calculated from a mass balance across the retention chest, and neglecting any volume change from mixing. Solving for the recirculation flowrate to the retention chest gives,

$$F_{rec} = (C_{ret}/KT_{905}) * dV_{ret}/dt + V_{ret}/KT_{905} * dC_{ret}/dt + FT_{220} * KT_{205}/KT_{905} - F_{pulper} * C_{pulper}/KT_{905} \quad (2.6)$$

The rate of volume change in the retention chest must be calculated from the retention chest level:

$$V_{ret} = 650 \text{ m}^3 * LT_{201}/100.0 \quad (2.7)$$

Due to oscillation in the retention chest level measurement during pulper discharging, F_{rec} cannot be calculated during pulper discharge to the retention chest. Therefore, determination of F_{rec} was calculated between batch discharging to the retention chest, using the last 10 minutes of process data prior to the next phase 5 discharge. The rate of volume change in the retention chest was calculated over a 5 minute interval with 1 minute sampling. The retention chest consistency during stock recirculation was calculated from equation 2.8:

$$C_{ret}(t_2) = ((V_{ret} * C_{ret})_{t_1} + (F_{pulper} * C_{pulper} + F_{rec} * KT_{905} + F_{ret} * KT_{205})_{t_2} * (t_2 - t_1)) / (V_{ret})_{t_2} \quad (2.8)$$

where $C_{ret}(t_2)$ is the updated retention chest consistency from time t_1 . F_{ret} can only be estimated from design specifications as 10% of the retention chest production flowrate, FT_{220} . The retention chest consistency is normally measured every 4 hours as part of standard process monitoring, and could be used as feedback to update Equation 2.6.

In order to test the accuracy of this model, process data was gathered using the Unix based DCS sampling program 'scan.c'. During periods of no recirculation, process measurements were used to determine how well the calculated level change in the retention chest compared with the on-line measurement values.

Flow transmitter FT₁₆₂, the pulper inlet flow meter, was found to be unreliable and subject to large errors in flowrate, and could not be used to determine the pulper flowrate F_{pulper} in Equation 2.5. Therefore, the effect of pulper addition was modelled by averaging the discharge flowrate to the retention chest during phase 5 discharge from the batch tonnage, consistency and discharge time. Because of the inability to calculate the pulper flow, and the disturbance of this flow on the level in the retention chest, the calculation of recirculation rate was limited to the period between batch discharging. Initiation of batch discharge can be detected from valve HV₁₄₃, which opens only during pulper discharge to the retention chest.

Figure 2.4 shows the calculated recirculation rate using a 1 minute sampling of process data. During this time period, the estimated recirculation flow from a material balance across the retention chest averaged 400 kg/min, while the actual recirculation rate was zero. In practice, pulp recirculation can be qualitatively detected by the opening of the recirculation valve HV910, and therefore the calculated recirculation flowrate need only be estimated during actual stock recirculation. Assuming an approximate stock recirculation rate of 3000 kg/min, a maximum error of 20% in the estimated stock recirculation flow could be expected. Examination of the retention chest level transmitter showed that the level fluctuations are oscillatory and difficult to measure, primarily because of the periodic discharge of pulp entering the chest from the pulper. Accurate measurement of the level change could only be obtained during a 10 minute period prior to pulper discharge. Therefore, the estimated recirculation rate from material balance considerations can only be determined during this time period. Figure 2.5 shows the simulated change in retention chest consistency during stock recirculation of 2500 kg/min at 8% consistency. Stock recirculation begins 110 minutes into the simulation, while pulper addition to the retention chest continued until 275 minutes into the simulation, at which time pulper production was stopped.

The retention chest consistency during recirculation can also be calculated by simultaneous solution of Equation 2.5 and Equation 2.7, which shows a water balance across the retention chest.

$$(1-C_{ret}) * dV_{ret}/dt - V_{ret} * dC_{ret}/dt = F_{rec} * (1-KT_{905}) - FT_{220} * KT_{205} * (1-C_{ret})/C_{ret} + F_{pulper} * (1-C_{pulper}) + F_{ret} \quad (2.9)$$

Solving Equation 2.6 for F_{rec} , and substituting into Equation 2.5 gives, after rearrangement, the rate of consistency change in the retention chest during recirculation:

$$dC_{ret}/dt = FT_{220} * (a_1/b_1) + FT_{162} * (a_2/b_1) - (a_3/b_1) * (dV_{ret}/dt) - F_{ret} * (a_4/b_1) \quad (2.10)$$

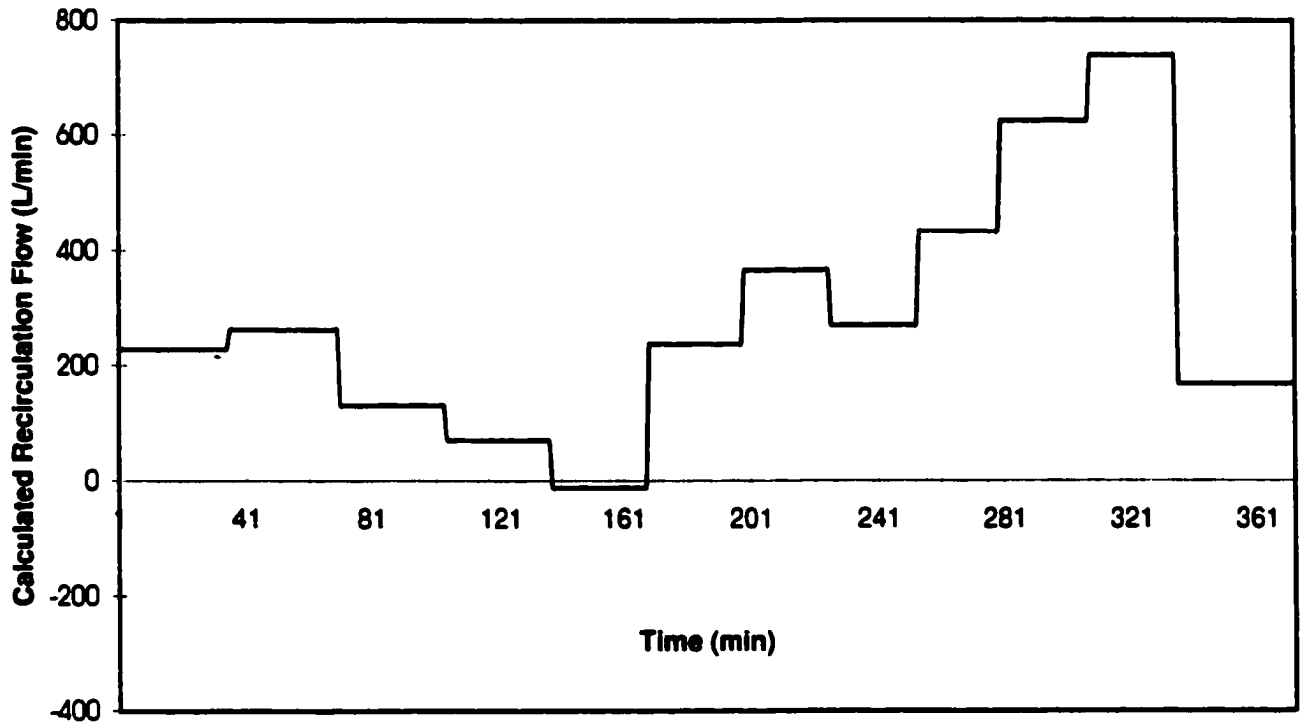

Figure 2.4 Estimated Stock Recirculation Rate Based on Retention Chest Material Balance Calculations

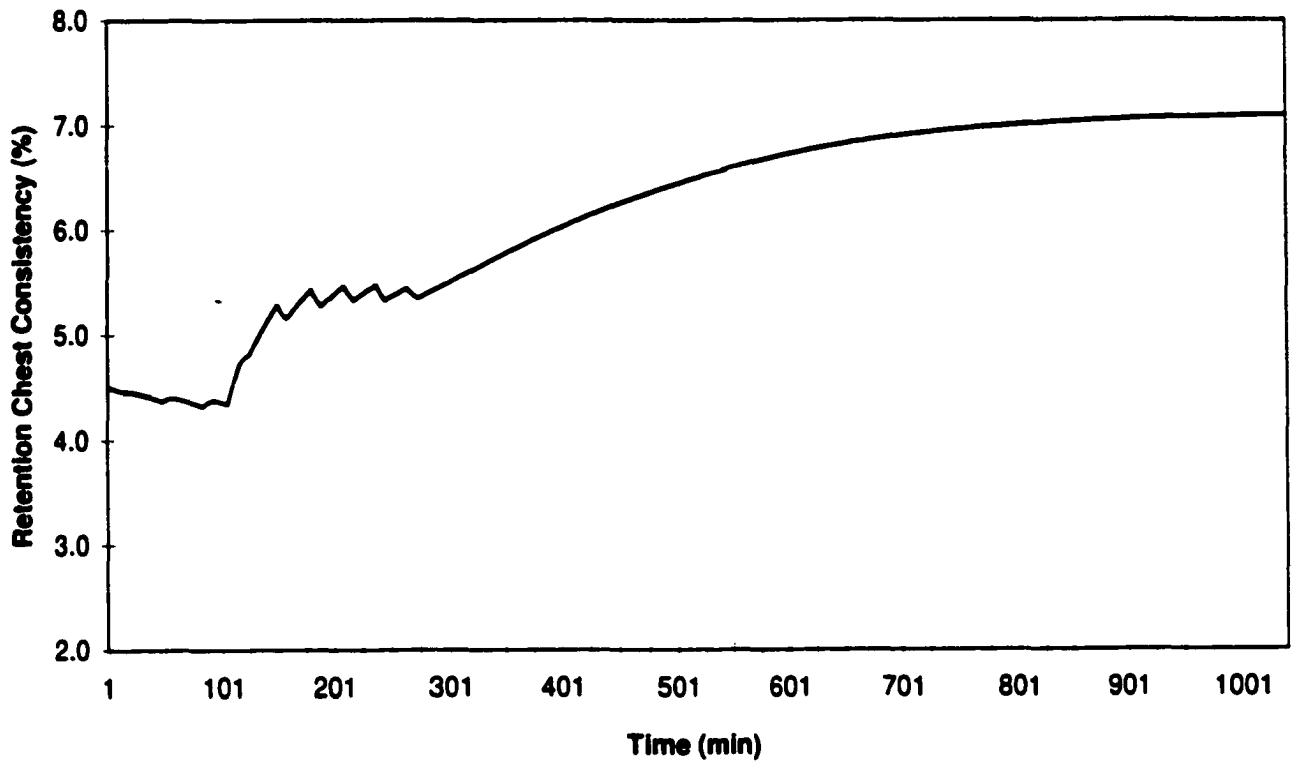

Figure 2.5 Retention Chest Consistency Change During Stock Recirculation at 290 tons/day

where

$$a_1 = KT_{205} * [(KT_{905}) / (1.0 - KT_{905}) * (1.0 - C_{ret}) / C_{ret} - 1.0] \quad (2.11)$$

$$a_2 = (1.0 - C_{pulper}) * ((KT_{905}) / (1.0 - KT_{905})) \quad (2.12)$$

$$a_3 = C_{ret} + (1.0 - C_{ret}) * ((KT_{905}) / (1.0 - KT_{905})) \quad (2.13)$$

$$a_4 = (KT_{905}) / (1.0 - KT_{905}) \quad (2.14)$$

$$b_1 = V_{ret} * [1.0 + (KT_{905}) / (1.0 - KT_{905})] \quad (2.15)$$

Substituting the calculated consistency change back into Equation 2.6 then allows calculation of the desired recirculation flowrate to the retention chest.

$$F_{rec} * KT_{905} = [C_{rec} * dV_{ret} / dt + V_{ret} * dC_{ret} / dt + FT_{220} * KT_{205} * (1.0 - C_{ret}) / C_{ret} - F_{pulper} * C_{pulper}] \quad (2.16)$$

High Density Storage Chest Modelling

Material balance analysis across the H.D storage tank was also examined as a means to calculate the stock recirculation flowrate. However, inventory calculations are made difficult by the dual-zone nature of the tank. The upper half of the storage tank consists of poorly mixed high consistency pulp which drains in a plug flow manner, while the bottom third of the H.D. storage tank consists of a dilution zone with low consistency pulp. Consequently the storage tank cannot be modelled as a stirred tank, and a pulp balance around the tank cannot be used. A flow balance around the H.D. storage tank could be used to estimate the recirculation rate as long as the volume change for mixing is negligible. Under this assumption a balance over the tank gives:

$$d/dt(V_{HD}) = F_{HDInlet} + FT_{1003} - (FT_{1002} - FT_{1004}) \quad (2.17)$$

$$V_{HD} = 700 * LT_{1008} / 100.0 \quad (2.18)$$

From which the recirculation rate can be inferred from the steady-state equation

$$F_{rec} = FT_{906} - F_{HDInlet} \quad (2.19)$$

FT_{1004} is the dilution water stream for tower consistency control. It cannot be measured, and cannot be neglected if an estimated accuracy of under 20% is desired. The design flow on the H.D. outlet is 5100 l/min, and the dilution water design flow is 570 l/min. Because level

measurement on the storage tank can be expected to give errors of up to 10%, calculation of the recirculation rate by this method was not pursued.

To compensate for the lack of available process measurements, empirical measurement of the effect of individual flow streams on the total volume change in the tank was considered. This procedure requires determining by measurement the effect of H.D. outlet production rate on tank level when the high density inlet flow is zero. This procedure must be repeated over a range of H.D. outlet consistencies and production rates to determine the effect of varying consistency on level change. The resulting data would provide a series of curves relating the production rate to the change in tank level for a given outlet consistency and flowrate. By repeating this procedure over a range of H.D. inlet consistencies and flowrates while the H.D. outlet flowrate is zero, the effect of inlet flowrate and consistency on H.D. tank level change can also be calculated. With these two models, the total volume change in the H.D. storage can be divided into a volume change from the inlet feed flow and the outlet flow. That is,

$$dV_{\text{tot}}/dt = dV_{\text{inlet}}/dt_{C_{\text{in}}} + dV_{\text{outlet}}/dt_{C_{\text{out}}} \quad (2.20)$$

where C_{in} and C_{out} are the inlet and outlet stream consistency. While the total tank volume change is measured from the level transmitter, the contribution of the outlet flow to the total volume change, dV_{outlet}/dt , can be determined from the empirically pre-determined relationship between the measured H.D. outlet flow and the tank volume change. This allows dV_{inlet}/dt to be calculated, from which the inlet flow can be determined.

This strategy offers the advantage of empirical data in building a model, but requires a significant amount of experimentation. A minimum of three experimental points for each curve at a given pulp consistency would require a minimum of 18 trials to develop a model.

This strategy was under consideration by the recycle department when it was determined that a flow transmitter was available for installation on the H.D. storage feed line. With the installation of the flowmeter, the recirculation flowrate will be calculated directly from the steady state equation:

$$\text{Recirculation rate} = F_{\text{rec}} * KT_{906} = (FT_{905} - F_{\text{HDInlet}}) * KT_{906} \quad (2.21)$$

The recycle department decided to wait for the installment of this flow transmitter before proceeding further with stock recirculation controls. The flowmeter has not been installed at this time. The possibility of estimating the recirculation rate to within 20% from material balance modelling on the retention chest has been demonstrated.

2.3 Operator Controls

Operator familiarity with the talc control system is important for successful implementation. The talc control system enables the operators to make changes through the DCS operator display windows shown in Figures 2.6 and 2.7.

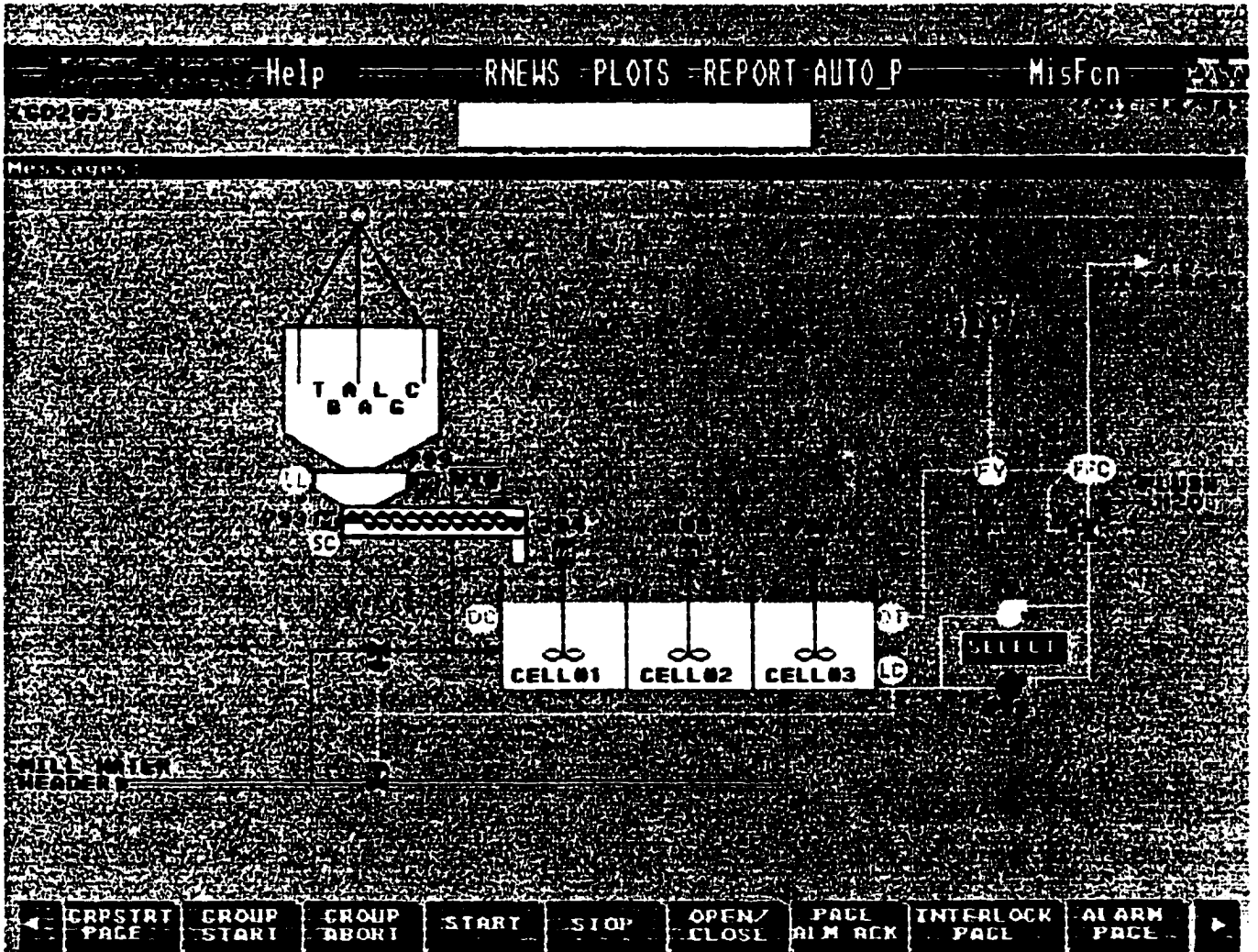

Figure 2.6 Talc System Operator Console Window Display

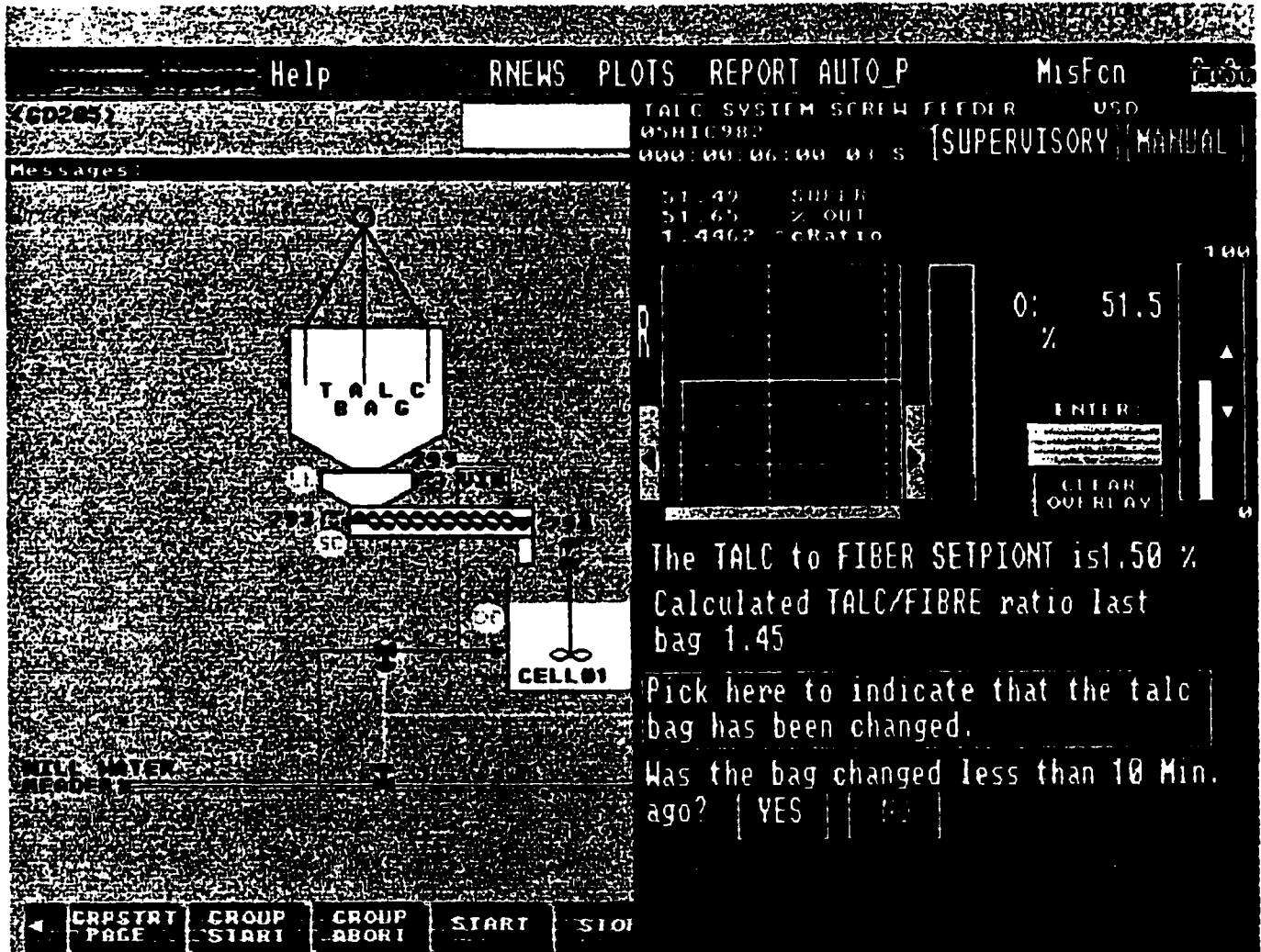

Figure 2.7 Talc System Window Display Showing Operator Inputs and Controls

The windows provide display for:

- a) A trend plot showing the deviation of the talc/fibre ratio from setpoint. This plot allows the operator to check several days worth of data.
- b) Toggle points for the operator to indicate when a talc bag change has occurred, and if this change was recorded properly.
- c) A toggle point to set the talc/fibre ratio setpoint.
- d) A toggle point to switch the controller from supervisory to manual.
- e) The talc slurry flowrate feeding the disperger.

Upon implementing the control system in the recycle plant, the operators were provided with a manual describing the basic operation of the control system. An important component in implementing the new system was operator acceptance and familiarity, which prior experience had demonstrated to be essential for successful implementation. The operator manual is shown in Section 2.4. Plant operators were encouraged to review the manual and point out concerns before final implementation of the control system.

2.4 Operator Manual: Talc Screw Feed Conveyor Control System

Process Sequence Block: :RN_TALC:TALC986.s

The purpose of the sequence block is to:

- a) adjust the talc feedrate to the disperger to satisfy the talc/fibre % ratio setpoint (typically 1.5%).
- b) model and adjust the relationship between the talc screw speed (as measured by the setpoint to the screw motor controls) and talc feedrate.

The relationship between the talc screw speed and the talc feedrate (kg/min) can be modelled as follows:

$$\begin{array}{l} \text{Talc feedrate} \\ \text{(kg/min)} \end{array} = k_1 * \begin{array}{l} \text{(Talc Conveyor Motor Setpoint)} \\ \text{(\%)} \end{array} \quad (2.15)$$

The talc screw motor setpoint is SC982.out. The constant k_1 relates the feedrate to the screw speed. This constant is adjusted each time a talc bag is emptied to compensate for any changes in the behaviour of the screw. Hence, after every talc bag change the program will adjust the screw speed-talc flow relationship to better control the talc feedrate.

Operator Screen Commands

From the talc control screen, (Figures 2.6 and 2.7) the operator can access the talc screw window to indicate a talc bag change. The window shows the following:

- a) the current talc/fibre ratio setpoint in percent
- b) the calculated talc/fibre ratio as estimated for the last talc bag. This estimate is updated at every talc bag change and only changes at that time.
- c) a toggle point to indicate when the operator changes over to a new talc bag. Toggling this button should (within 3 minutes) show a bump in the trend lines. The calculated talc/fibre ratio for the last bag will also change on the trend line and on the worded display. The screw speed (seen on the trend line) will usually change slightly as the screw adjusts to better control the talc flow.
- d) a toggle point (yes/no) to indicate if the operator has indicated this talc change within 10 minutes of the actual time of changing the bag. If the operator has forgotten to indicate a talc change at the correct time, he should click the no button.
- e) the DCS historian trend line shows the past screw speed in % and the calculated talc/fibre ratio for previous talc bag cycles.

The operators interact with the control block via the DCS console windows, as shown in Figures 2.6 and 2.7. Figure 2.6 shows the process operator window for monitoring the talc conveyor system. From this window the operators can access information on inventory and flowrates in the talc mixing cells. By activating the clickable box on the talc conveyor screw, the operators can call up the window shown in Figure 2.7. From this window, the operator can monitor the talc conveyor speed (51.5%), the current talc/fibre ratio (1.45). The operator can also set the talc controls to supervisory or manual, adjust the talc/fibre ratio setpoint (currently 1.5%), and indicate when a talc bag change has occurred. By indicating whether the operator has entered the talc bag change during the last 10 minutes, the program can determine if a valid estimate of the talc metering behaviour can be inferred from the last talc cycle.

In supervisory mode, the program continuously samples the tons/day measurement to the twin-wire press (TWP) and averages this data. Every 3 minutes (1 sample period) the program adjusts the talc screw speed to correctly ratio the talc feedrate to the TWP tons/day flow. If the production rate is fairly constant, the screw speed should remain constant. To check that the program is still running, the operator can toggle the historian trend line bar at previous sample points. Although the trend line may appear flat, the actual screw speed will vary slightly (ie. move from 25.2% to 25.5% to 24.9 etc.) . When the operator changes plant production rate (as measured at the TWP), the screw speed will change to supply the correct talc flow.

By adjusting the talc/fibre ratio setpoint (usually at 1.5%), the operator can control the talc/fibre ratio. The program will automatically adjust the talc addition rate to satisfy the new setpoint. Although the algorithm is normally in supervisory control, the operator is free to change to manual mode without affecting the proper performance of the algorithm. However, whether in manual or supervisory mode the operator should still indicate when a talc bag is changed and if this was done correctly. When the operator changes back to supervisory mode the program will automatically begin metering the correct talc flow.

The talc control program keeps track of the total amount of talc added to the process and attempts to predict when a talc bag has been used up. If the program estimates that a talc bag change should be occurring, an operator alert message appears at the control screen message terminal to alert the operator. Should the operator forget to update the talc bag change, the alert will ensure that the talc conveyor calibration is updated after each talc change. If the screw calibration curve is inaccurate, the algorithm may predict a talc bag change too early, in which case the operator can ignore the alert.

Talc Feed Slurry Control

The talc screw feeds the correct amount of talc to the mixing cells. The talc slurry flow control system (FFIC985) then adjusts the flowrate of slurry out of the mixing cells to deliver the correct amount of talc to the disperger. In response to changing talc demand, the flow control loop FFIC985 adjusts the flowrate of slurry to the disperger to supply a talc/fibre ratio of 1.5% (or as specified by TALC_SPT). When adjusting the talc/fibre setpoint, the program automatically readjusts the talc addition rate to the new set point

Temporary Shutdown Or Power Loss

During periods of temporary plant shutdown (less than a day), the talc program will stop execution and remain inactive until the plant starts back up. At start-up the program will automatically begin operating again. A temporary shut-down should not interfere with the proper operation of the control system, and upon start-up the program can be placed in supervisory mode.

The control program also monitors the operation of the screw conveyor to ensure it is in active operation. In the event of conveyor failure the program will halt and wait for the conveyor to begin operating correctly.

Initialization (Transfer from Manual to On-line)

Before placing the algorithm on-line (that is, starting the sequence block from the compiled program), the talc screw loop should be performing properly under manual control (ie feeding the correct amount of talc for the current production rate). If the loop is put on automatic when operating poorly, the talc screw may not perform well until the next talc bag change when

the screw calibration curve updates. Re-starting the sequence block is not the same as placing the talc control program in manual mode. In manual mode the talc program still continues to run and can be placed in supervisory mode at any time. Re-starting the sequence block will normally only occur if the program stops executing due to an error or after an extended shutdown. Usually, if the program is not performing satisfactorily in supervisory mode, the operator would simply place the talc control in manual until the next talc bag change. At that time the screw should behave better.

If at any time the screw begins behaving unreliably, the operator can place the algorithm in manual and set the screw speed to provide for correct operation. Upon the next talc bag change, the algorithm will update the changes in the screw behaviour and should then operate properly in supervisory mode from the on-line recalibration of the screw behaviour.

Talc Feed Adjustment During Recycle

During periods of stock recirculation from the bleach tower outlet to the retention chest, the talc recirculating in the plant must be accounted for in order to satisfy the talc/fibre ratio set point of 1.5% at the disperger.

To do this, the talc program estimates and stores the amount of talc returning to the retention at each sampling time. When this talc circulates through the process back to the disperger, the program adjusts the talc screw speed to compensate for the talc already present in the recirculating stock. Thus, during periods of stock recirculation, the amount of talc used will be automatically reduced to compensate for the presence of recirculating stock.

2.5 Results and Discussion

The talc control has achieved the primary objectives outlined in Section 2.1. The supervisory talc control system has provided a means for automatic monitoring and update of the talc conveyor screw behaviour, thereby removing the necessity for regular monitoring by process operators.

Figure 2.8 shows the estimated percent wt talc/fibre ratio achieved during operation of the talc supervisory control system. The oscillation around the set point is attributable to the random changes of the talc conveyor metering behaviour over time. These changes in the conveyor behaviour caused by partial plugging of the screw rungs are significant and cannot be effectively monitored by operators. The metering system has enabled long term control of the talc addition rate to within 25% of the target setpoint. Table 2.0 summarizes the performance of the talc conveyor controls demonstrating long term control of the talc concentration on pulp at 1.5%.

The talc control system has enabled Avenor to control talc addition without the need to replace the density transmitter on the talc mixing tank, providing for capital savings of over \$25,000 [28].

The implementation of the supervisory talc control system has removed the necessity for regular monitoring of the talc conveyor behaviour, and provided direct feedback to the operators on the amount of talc being added to the pulp. The operators understand the purpose of the control system, and have accepted its use. The supervisory talc control system has been in operation at Avenor since January 1997.

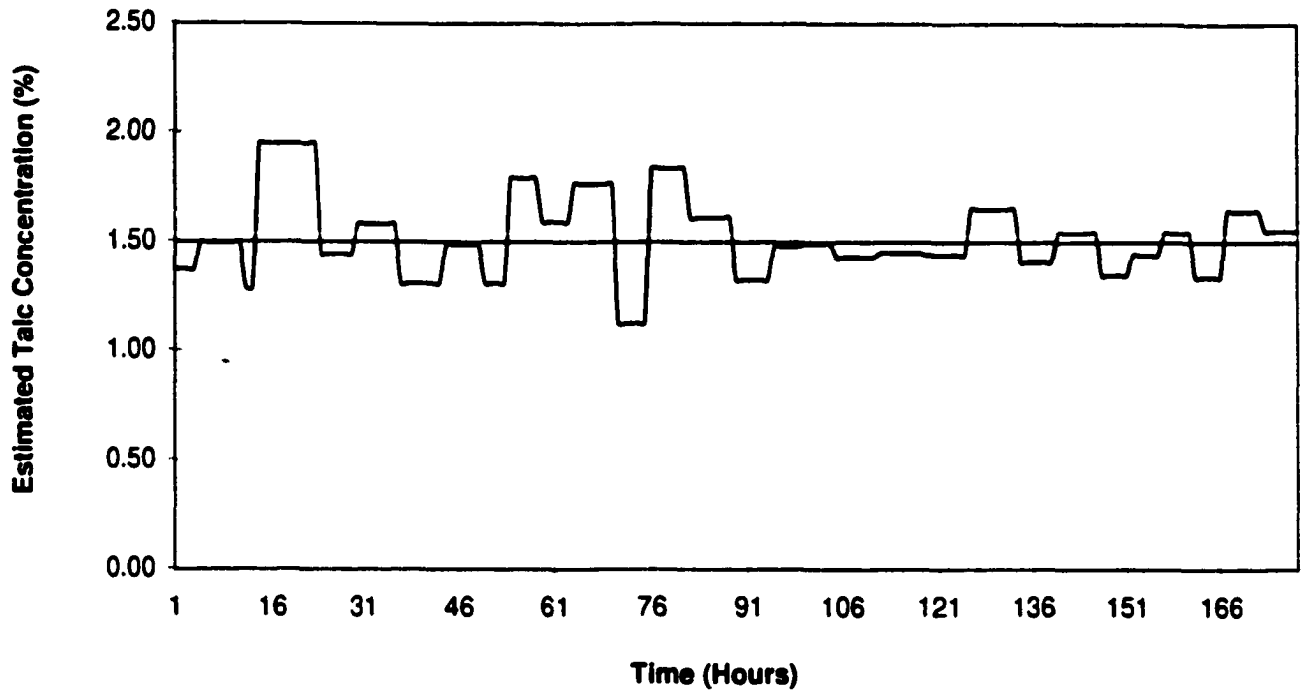

Figure 2.8 Estimated Talc Concentration on Pulp Achieved Under Supervisory Control For a Talc Concentration Setpoint of 1.5% odp

Table 2.0 Summary of Talc Control Performance for Figure 2.8

Talc Concentration Set Point %	1.50%
Average Talc Concentration Achieved	1.51%
Talc Concentration Variance	0.025
Maximum % Deviation From Set point	26%

Chapter 3

An Investigation Into the Sources of Flotation Cell Inlet Brightness Variation

3.0 Introduction

Brightness variation has been a constant problem which is costly in terms of chemical costs and lower pulp quality and downtime. An important source of brightness variation is the changing wastepaper quality. It is difficult to adequately compensate for low quality paper before a brightness problem is detected. Although efforts have been made to grade and process waste paper according to quality, much of the brightness variation cannot be explained by variations in process variables.

Figure 3.0 shows the brightness variations during a representative 12 hour period. The brightness varies significantly over this period, from a low of 46.6 ISO to a high of 50.0 ISO. The plot shows continuous oscillations in brightness level with periods ranging from 10 minutes to several hours.

Flotation brightness alarms signal a low brightness alerts if the brightness drops below 45. Low brightness requires compensatory action to ensure an acceptable brightness level on the final pulp, as shown in Figure 3.1, which demonstrates the correlation between the flotation brightness in Figure 3.0 and the final pulp brightness achieved at the H.D. storage outlet after accounting for the 130 minute time lag between flotation brightness and final stock brightness. Compensating for this continuous brightness variation occasionally requires adjustment of the chemical addition dosages during pulping, to compensate for higher levels of ink and contaminants in the waste paper feed which cannot be corrected by lowering plant production rate or increasing downstream chemical use.

3.1 Variables for Process Investigation: Results and Discussion

In order to better understand the causes of this brightness variation, the effect of process variables on flotation brightness was studied. Variables examined include:

- a) Pulping Sodium Hydroxide dosage
- b) Pulping Hydrogen Peroxide dosage
- c) Pulping $H_2O_2/NaOH$ ratio
- d) Pulping Sodium Silicate dosage
- e) Pulping DTPA dosage
- f) Percent Magazine addition
- g) Production Rate
- h) Consistency Effects
- i) Primary and Secondary Screens Rejects Rate
- j) Grey Water makeup flow to the Grey Water Chest

Process data was sampled during January, February and March 1997 to determine the

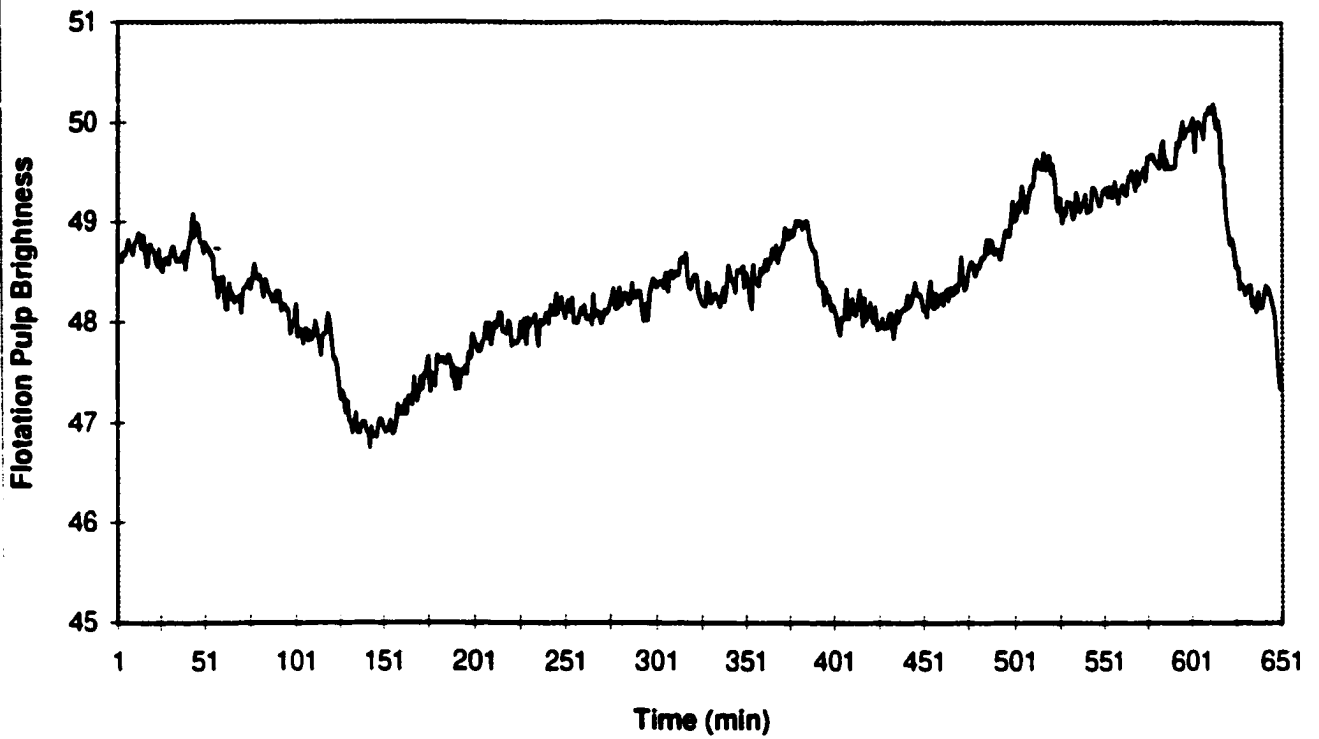

Figure 3.0 Typical Variation in Flotation Inlet Brightness During Plant Operation

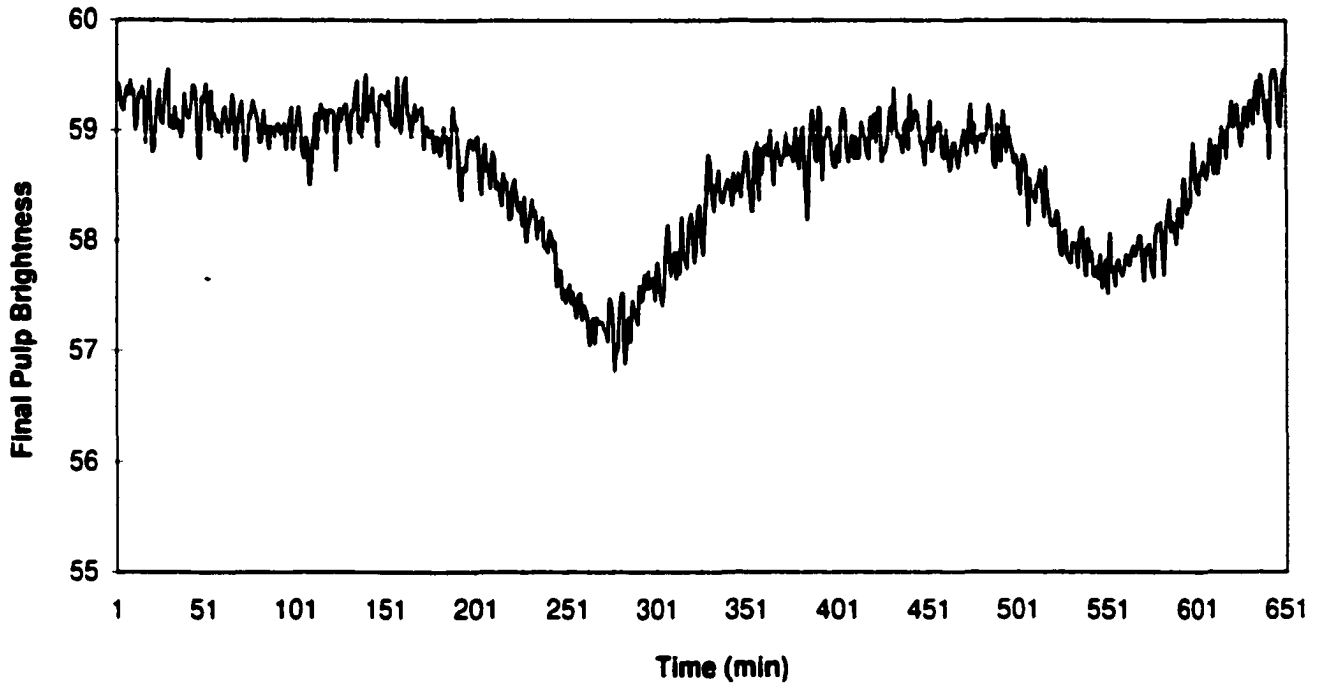

Figure 3.1 Final Pulp Brightness Achieved From Flotation Inlet Brightness Variation of Figure 3.0

Table 3.0 Summary of Flotation Inlet Brightness-Process Variable Correlations

	Process Variable	Figures Referenced	Correlation	Time Shift (min)
Flotation Inlet Brightness	Final Stock Brightness	3.0, 3.1	76%	120
Flotation Inlet Brightness	Hydrogen Peroxide	3.2, 3.3	10%	85
Flotation Inlet Brightness	Sodium Hydroxide	3.2, 3.4	18%	85
Flotation Inlet Brightness	H ₂ O ₂ /NaOH Ratio	3.2, 3.5	38%	85
Flotation Inlet Brightness	H ₂ O ₂ /NaOH Ratio	3.6, 3.7	52%	35
Flotation Inlet Brightness	Sodium Silicate	3.2, 3.8	19%	85
Flotation Inlet Brightness	DTPA	3.9, 3.10	64%	30
Flotation Inlet Brightness	Percent Magazine	3.11, 3.12	-12%	75
Flotation Inlet Brightness	Production Rate	3.2, 3.13	55%	5
Flotation Inlet Brightness	Production Rate	3.14, 3.15	-6.0%	5
Flotation Inlet Brightness	Production Rate	3.16, 3.17	-25%	5
Flotation Inlet Brightness	Production Rate	3.18, 3.19	19%	5

source of brightness variation. Pulper variables were correlated by time shifting the flotation brightness measurements to obtain the best correlation possible within the residence time of the retention chest. The results of the brightness-process variable correlation investigation is summarized in Table 3.0.

As discussed in Chapter 1, sodium hydroxide and hydrogen peroxide are important variables in brightness control. Sodium hydroxide assists the hydrolyzing ink resins and the separation of ink from fibres surfaces, thereby allowing for improved ink removal. Hydrogen peroxide in turn acts to protect against alkali darkening associated with the presence of sodium hydroxide. To determine if sodium hydroxide or hydrogen peroxide were responsible for brightness variations, variations in chemical dosage during pulping were compared with the flotation inlet brightness. Chemical dosages were determined from the measured addition of chemicals to the pulper and the batch tonnage. Because chemical addition concentrations are constant, the volume of chemicals added is a direct measure of the chemical dose. Figures 3.3 and 3.4 shows the variation in chemical addition of peroxide and hydroxide during a 10 hour period associated with the flotation cell inlet brightness variation of Figure 3.2. Both sodium hydroxide and hydrogen peroxide show only weak correlation with the brightness variation. The correlation coefficient between brightness and sodium hydroxide was 0.18, while the correlation coefficient for brightness and hydrogen peroxide was 0.10.

In addition to the separate effects of sodium hydroxide and hydrogen peroxide addition, the hydrogen peroxide to sodium hydroxide ratio was investigated as a variable to measure the effects of alkali darkening on brightness loss. The optimal dosage of hydrogen peroxide varies with the sodium hydroxide dosage, and therefore changes in the ratio of these two variables could potentially effect brightness gain. Figure 3.5 shows the peroxide-hydroxide ratio during the batch run. Although the drop in brightness appears to be correlated with the peroxide/hydroxide ratio during the first 200 minutes of the run, it can be seen to be uncorrelated by the continuing drop in brightness after the peroxide-hydroxide ratio stabilizes.

Evidence of a relationship between brightness and the peroxide-hydroxide ratio could not be established. As shown in Figures 3.6 and 3.7, the inlet brightness did demonstrate a weak correlation with the peroxide/hydroxide ratio at times. The peroxide/hydroxide ratio shown was calculated by filtering the peroxide/hydroxide ratio over the previous 40 minutes of batch time, to represent an approximation to the mixing behaviour in the retention chest. Although the correlation appears strong, repeated monitoring of process data did not demonstrate a relationship between brightness and peroxide-hydroxide ratio.

Silicate is an important variable in pulper brightness gain, both as an ink dispersant and to help prevent hydrogen peroxide decomposition. Under addition of silicate is commonly detected as a sudden loss in pulper brightness, and therefore silicate addition was monitored for its effect on pulp brightness. Figure 3.8 shows the silicate dosage variation during the brightness run shown in Figure 3.2. The correlation coefficient between silicate and brightness was 0.19, and no reproducible relation between brightness and silicate could be found.

DTPA functions as a chelating agent to prevent the catalytic decomposition of hydrogen peroxide by dissolved metals. As such, under addition of DTPA can result in excess



Figure 3.2 Flotation Inlet Brightness Variation for Figures 3.3, 3.4, 3.5, 3.8, and 3.13

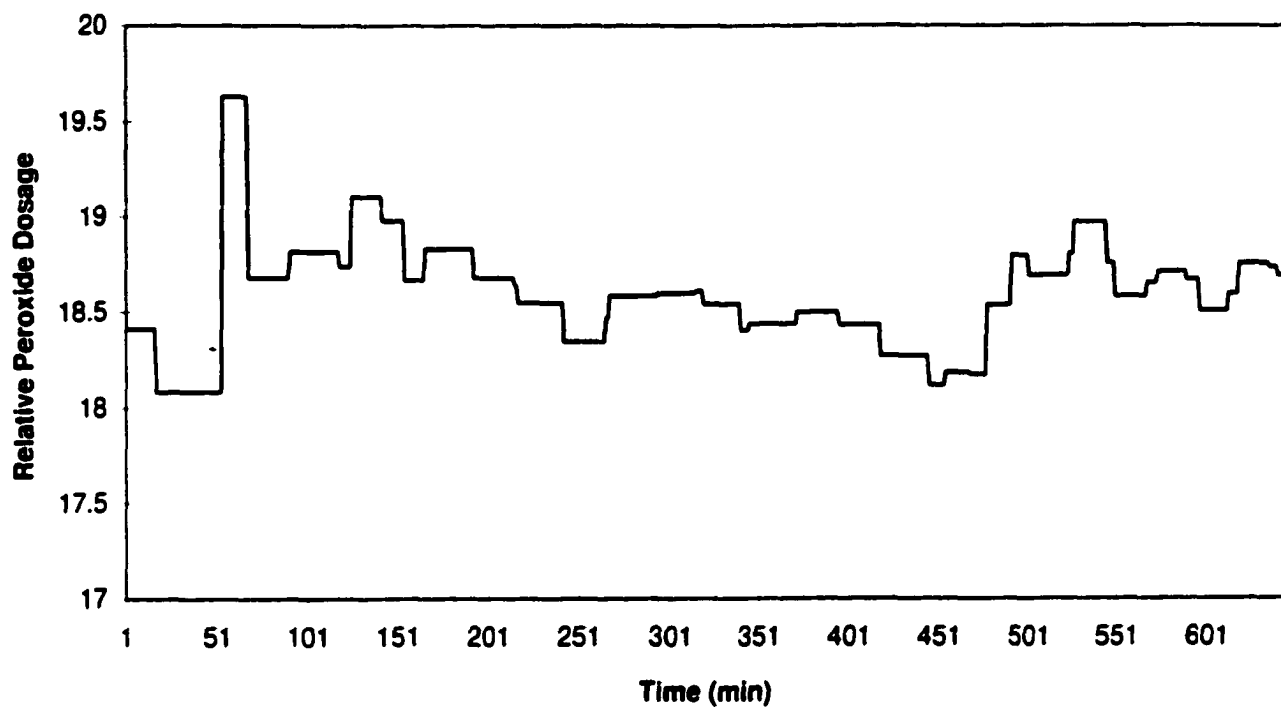

Figure 3.3 Hydrogen Peroxide Chemical Dosage Variation Per Ton of Pulp

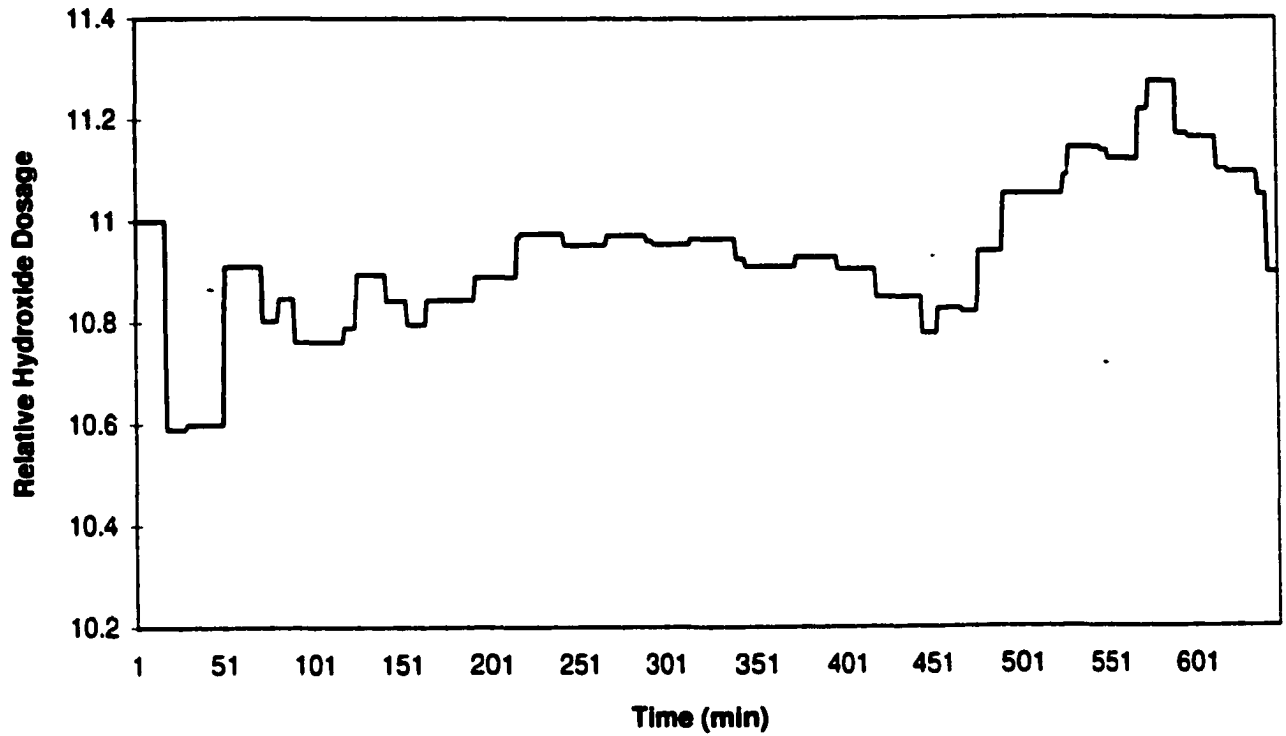

Figure 3.4 Sodium Hydroxide Chemical Dosage Variation Per Ton of Pulp

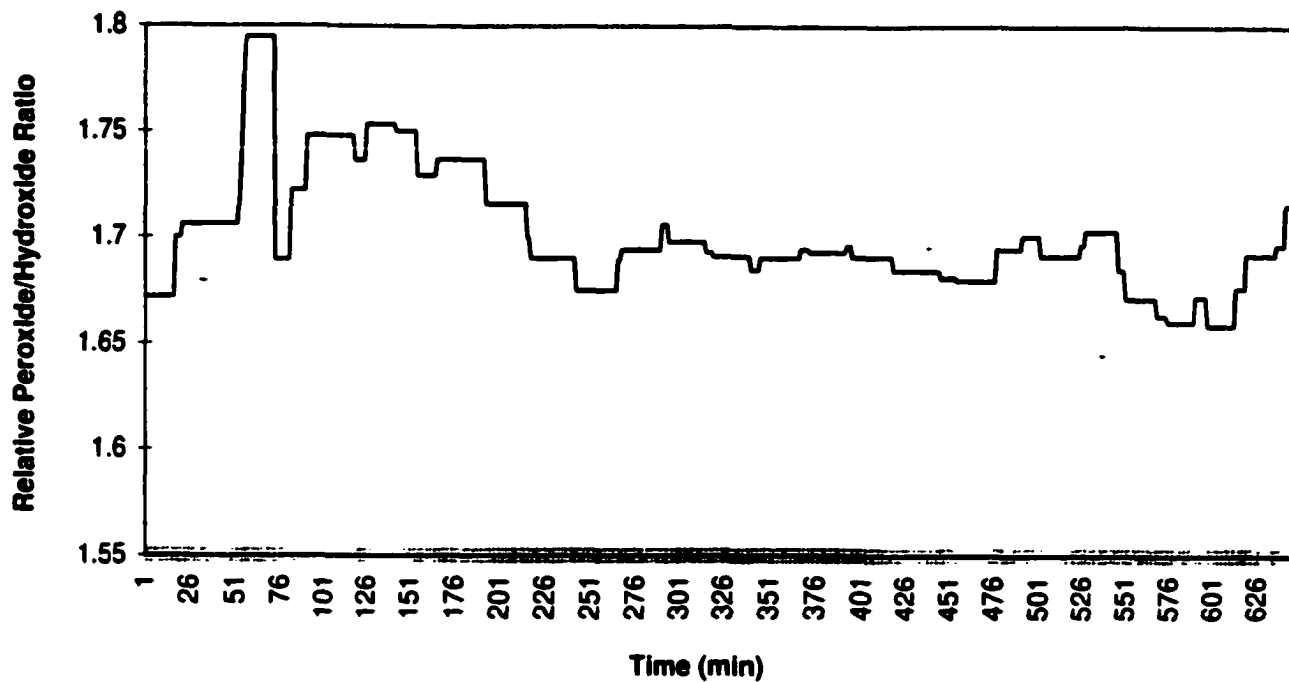

Figure 3.5 Hydrogen Peroxide/Sodium Hydroxide Ratio Variation During Pulping Operation

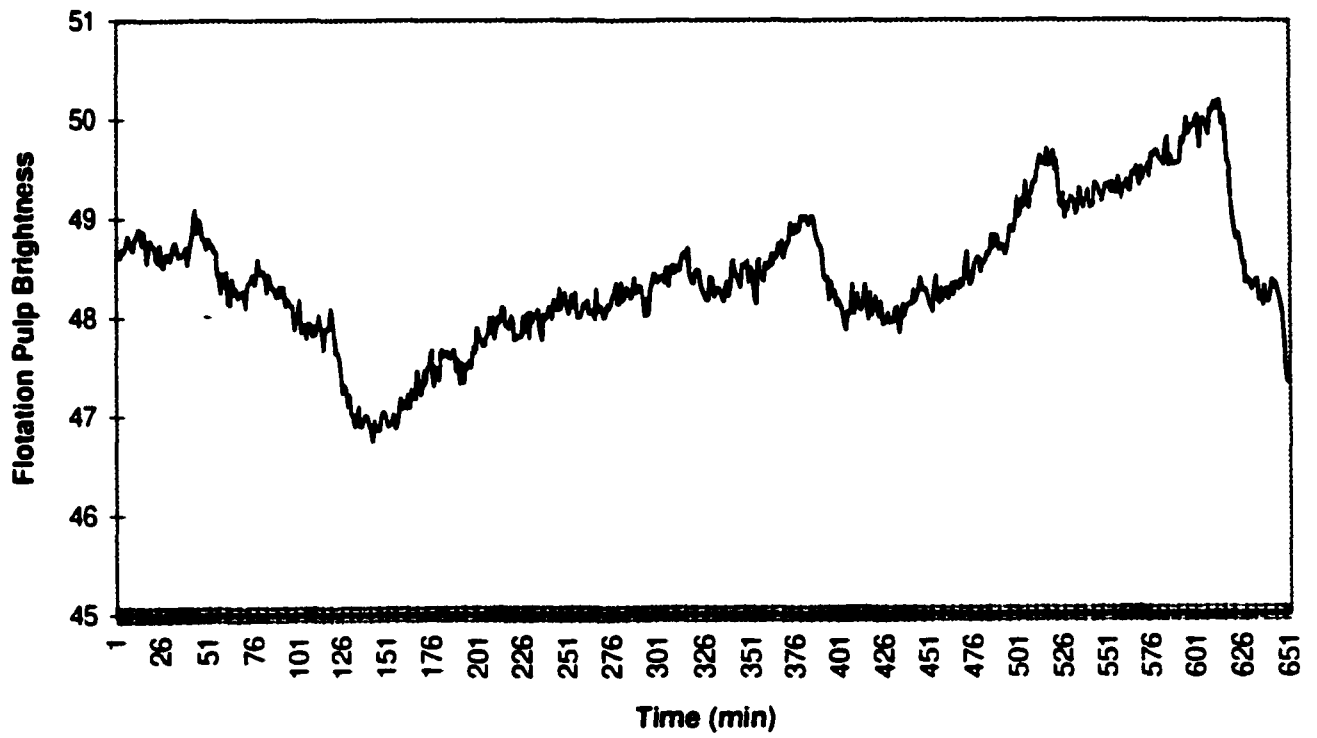

Figure 3.6 Flotation Inlet Brightness Variation For Figure 3.7

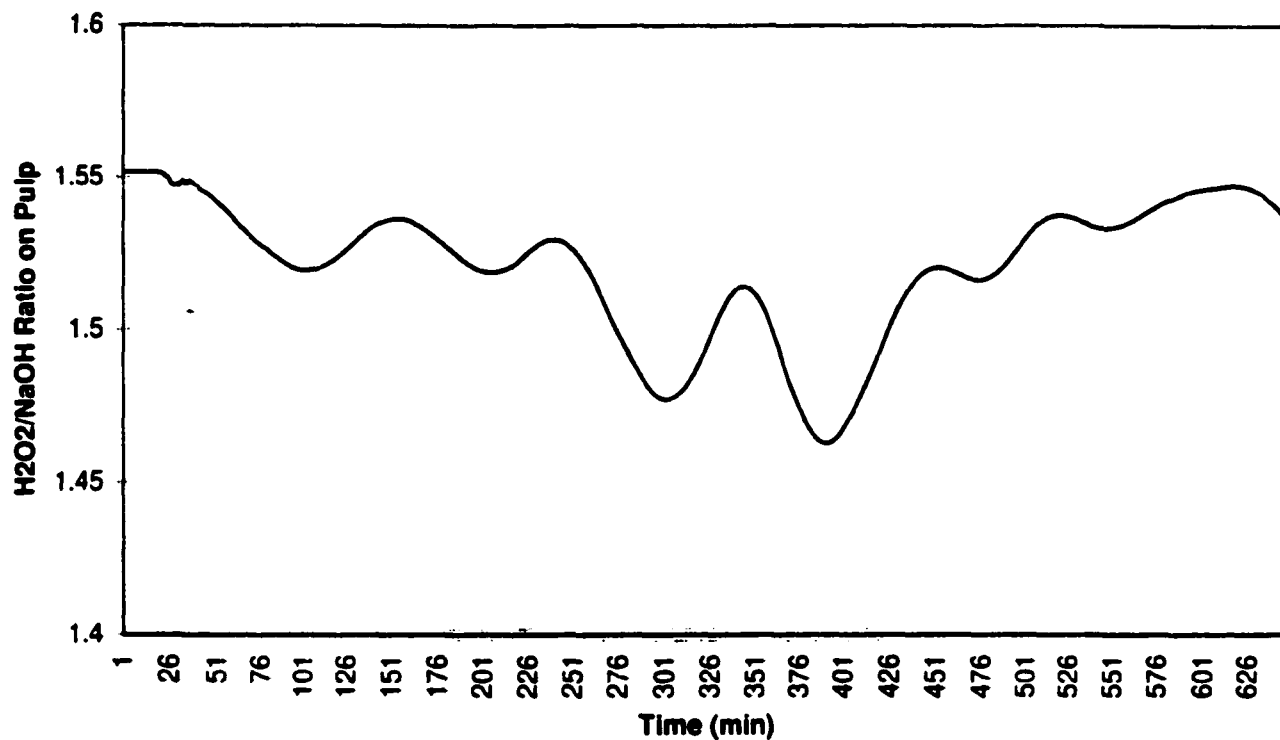

Figure 3.7 Hydrogen Peroxide/Sodium Hydroxide Ratio Variation

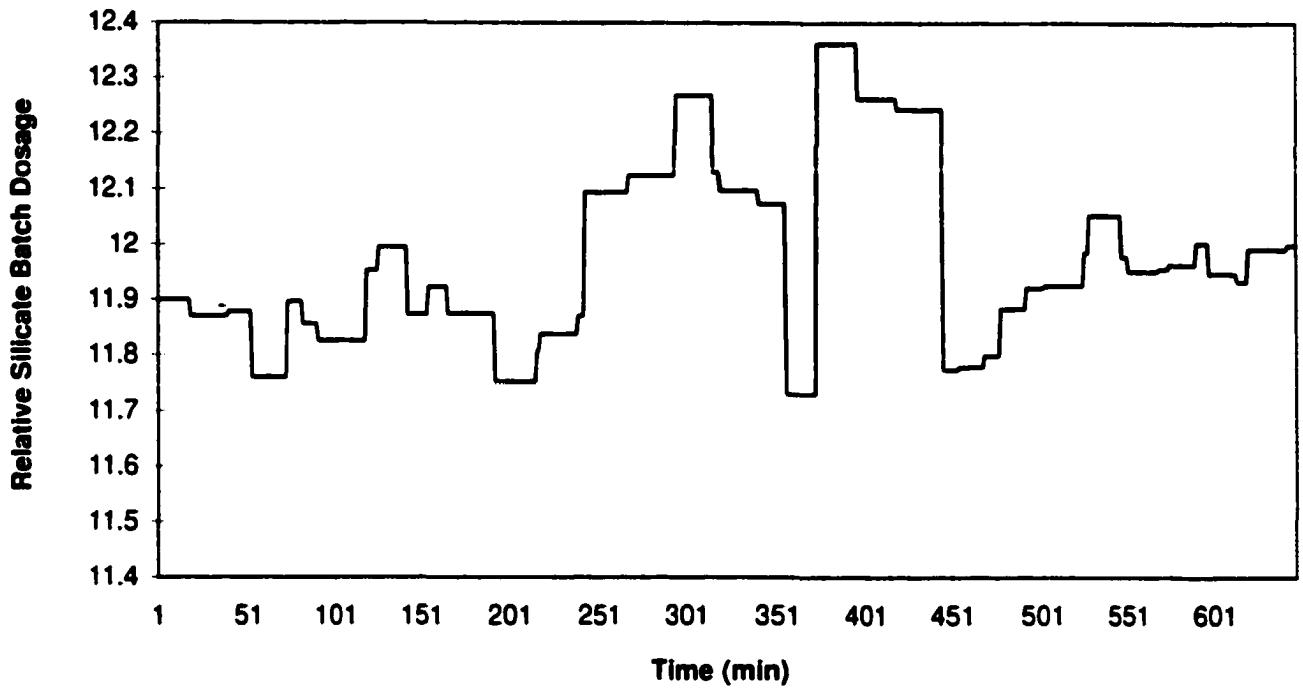

Figure 3.8 Sodium Silicate Chemical Dosage Variation Per Ton of Pulp

consumption of hydrogen peroxide and alkali darkening, which negatively impacts on pulp brightness. However, DTPA is not required for brightness gain, and low DTPA levels will not necessarily cause brightness variations. Rather, the amount of DTPA required to prevent hydrogen peroxide degradation depends on the concentration of dissolved metals present in the grey water system, a variable which is not measured. DTPA addition is therefore chosen to protect against the probable concentration of dissolved metals found in the grey water system. Thus variations in DTPA may not impact on brightness gain. Low levels of residual peroxide in the retention chest outlet would indicate excess peroxide degradation, and would indicate a potential need for higher levels of DTPA addition. However, previous investigation of residual peroxide levels at the flotation inlet demonstrated adequate residual peroxide levels to prevent brightness reversion [29].

Repeated investigation of the variation in DTPA levels did not demonstrate a correlation with flotation brightness. However, as shown in Figure 3.9 and 3.10, variations in the DTPA dosage by up to 50% have been found to correlate with pulp brightness variations. The correlation coefficient between DTPA and pulp brightness during this period was found to be 0.65. The large variation in DTPA levels found during this run did not occur regularly, and the smaller variations in DTPA dosage were not found to correlate significantly with brightness variations.

The addition of magazine stock to pulping operations has been found to improve brightness gain, primarily due to the presence of clays which aid in ink dispersion. Variations in magazine addition were therefore investigated to determine if they were correlated with flotation inlet brightness variation. Figures 3.11 and 3.12 shows a typical plot of the percent magazine addition and brightness variation during an 8 hour period. No significant correlation between magazine and brightness was found. Batch to batch variations in magazine content between 18-25% were not found to correlate with changes in pulp brightness.

Plant production rate has been suggested as a cause of varying brightness, and it was desired to investigate whether production rate changes could be used to control brightness. Specifically, reductions in production rate were found to produce temporary increases in pulp brightness, while production rate increases were followed by a drop in pulp brightness at the flotation inlet. The possibility of lowering production rate to improve plant brightness was suggested as a means to accommodate low pulp brightness at the flotation cells. Figure 3.13 shows the changes in pulp brightness associated with an increase in plant production rate from 300 to 370 tons/day over a 6 hour period. The plant production rate shows significant correlation with pulp brightness, with a correlation coefficient of 0.55. However, as Figures 3.14 and 3.15 show, production rate changes do not always lead to flotation inlet brightness changes. Here the production rate was suddenly increased from 350 to 390 tons/day for approximately 20 minutes, before dropping to 290 tons/day at 410 minutes. The brightness showed no response to the production rate changes, continuing to drop to 47 ISO before stabilizing. The 60 ton/day drop in production rate after 335 minutes did not produce a significant change in measured brightness.

Pulp brightness also shows similar patterns of variation during periods of constant production rate. As figures 3.16 and 3.17 show, significant brightness fluctuations continue to

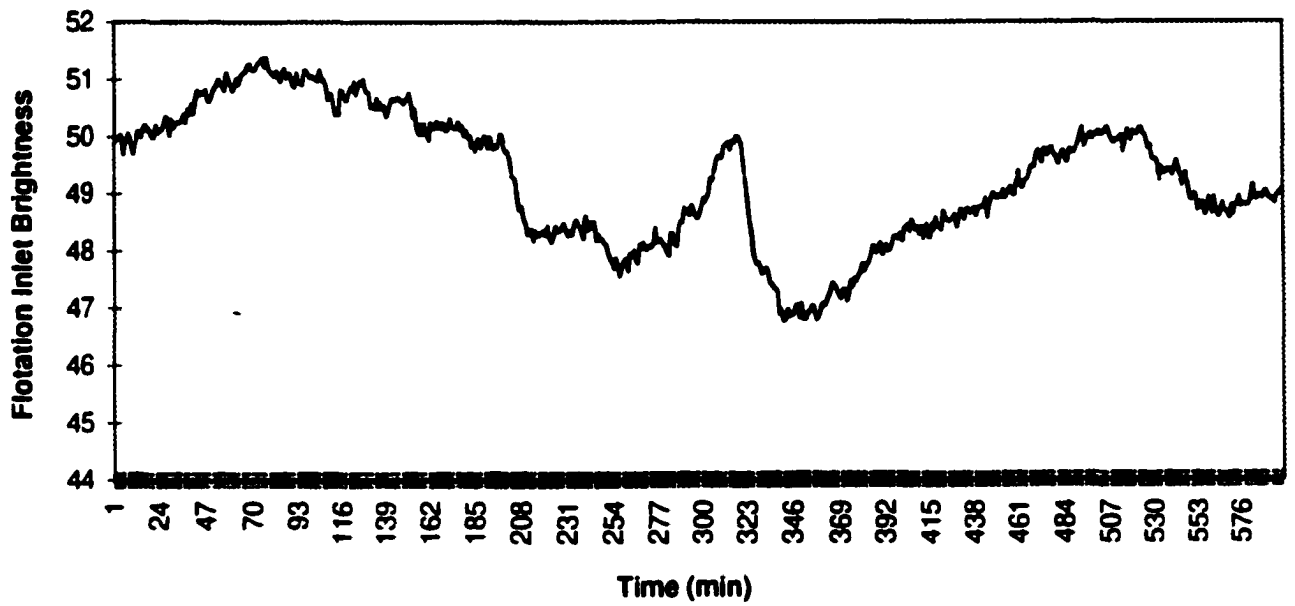

Figure 3.9 Flotation Inlet Brightness Variation For Figure 3.10

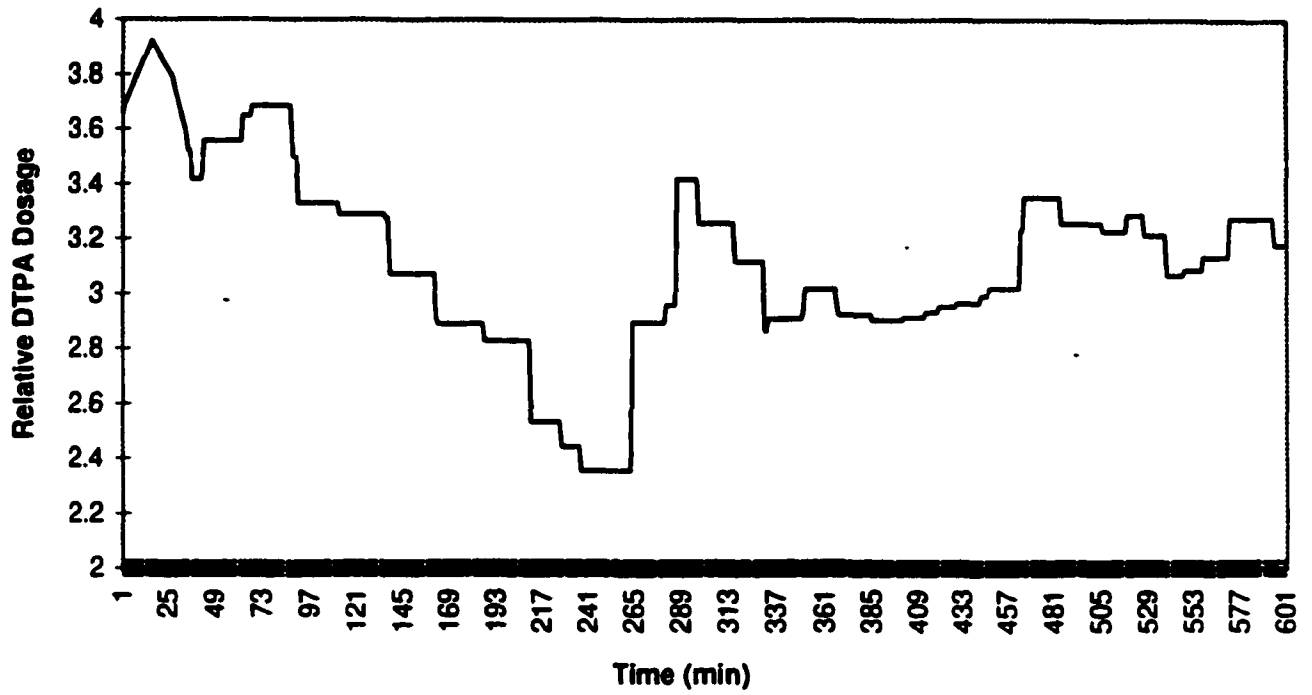

Figure 3.10 DTPA Chemical Dosage Variation Per Ton of Pulp

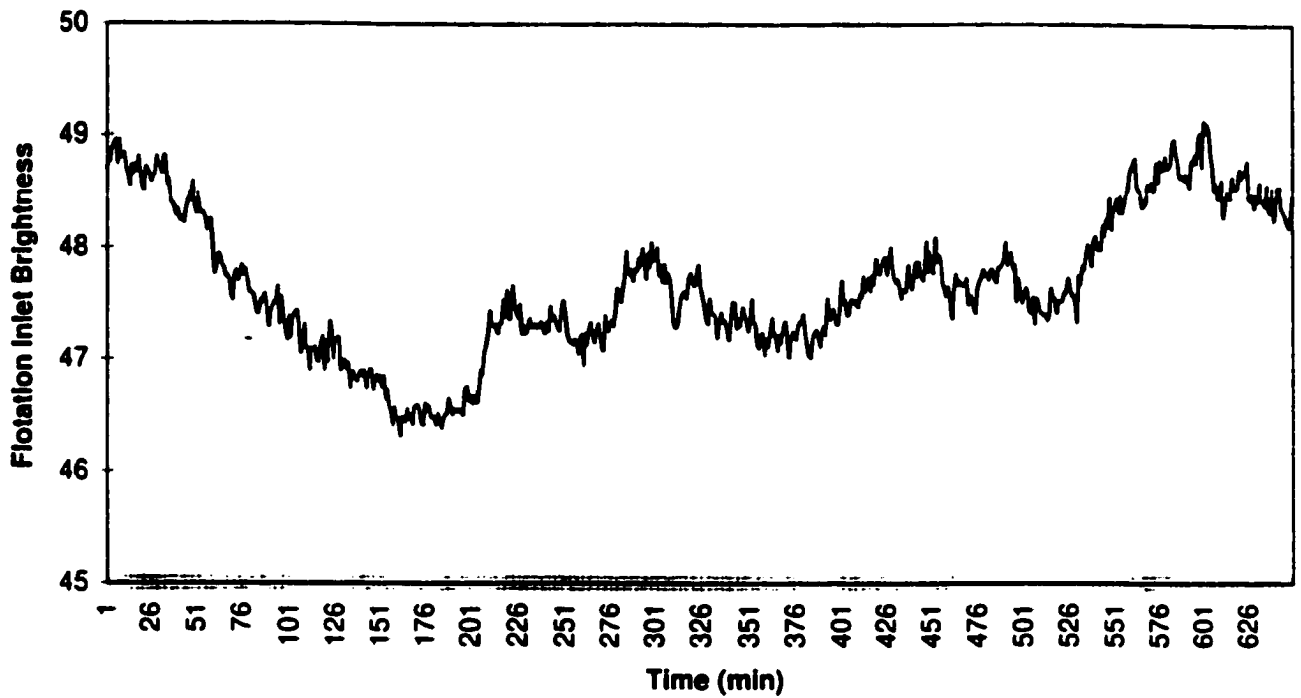

Figure 3.11 Flotation Inlet Brightness Variation For Figure 3.12

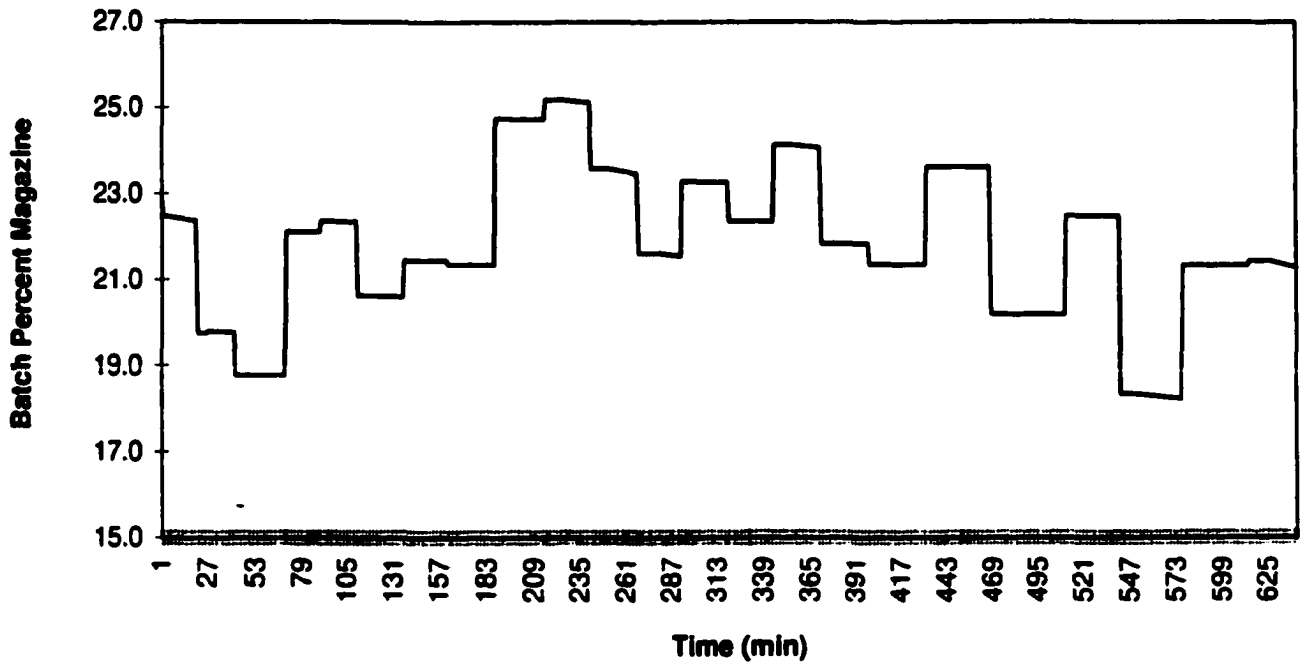

Figure 3.12 Percent Magazine Batch to Batch Pulping Variation

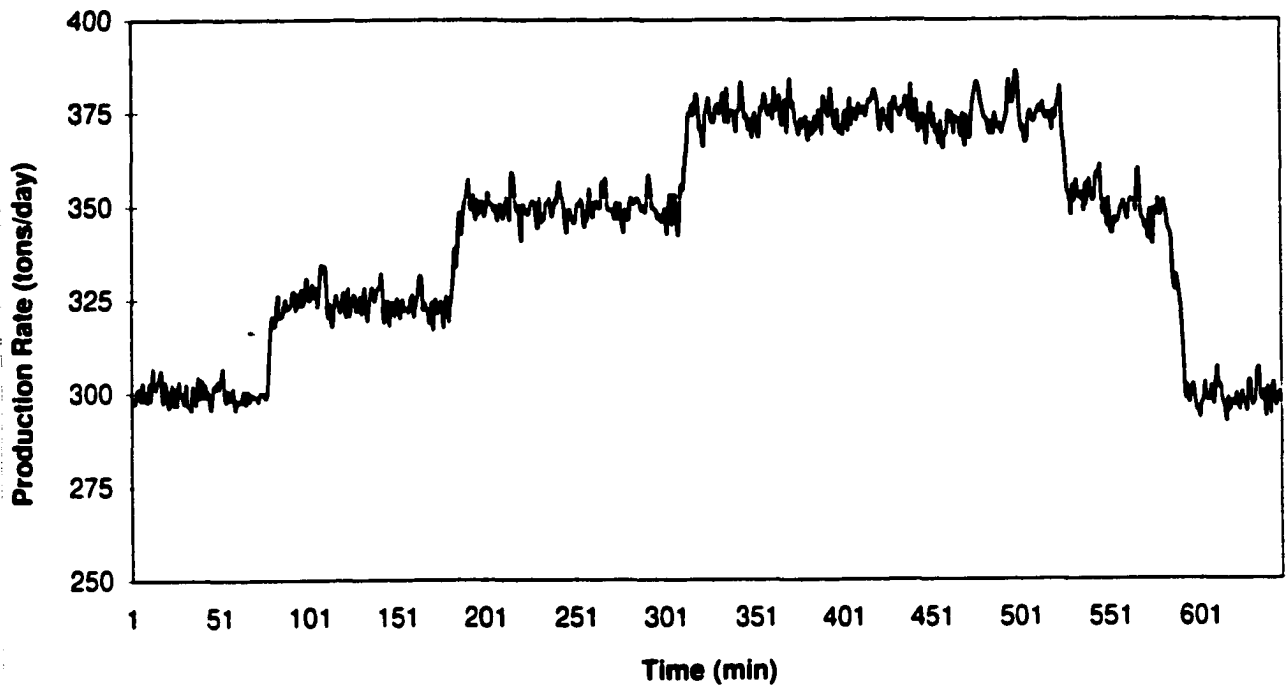

Figure 3.13 Retention Chest Plant Production Rate For the Flotation Inlet Brightness Variation of Figure 3.2

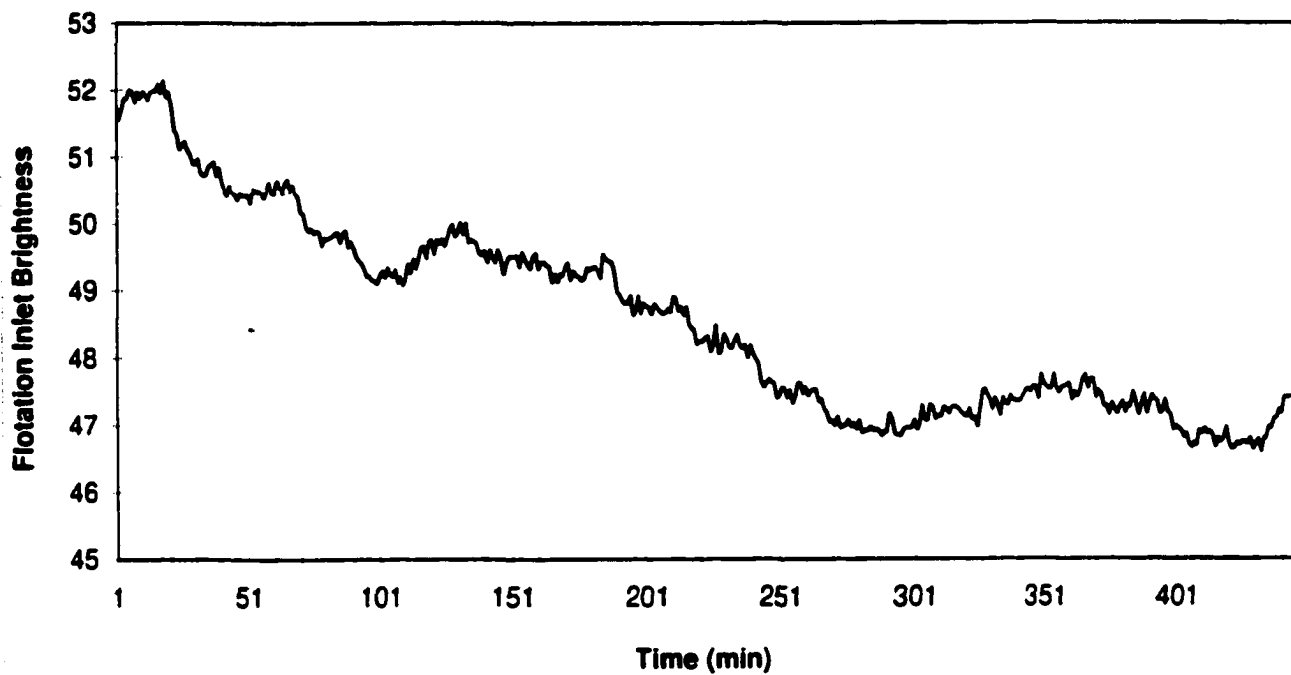

Figure 3.14 Flotation Inlet Brightness Variation For Figure 3.15

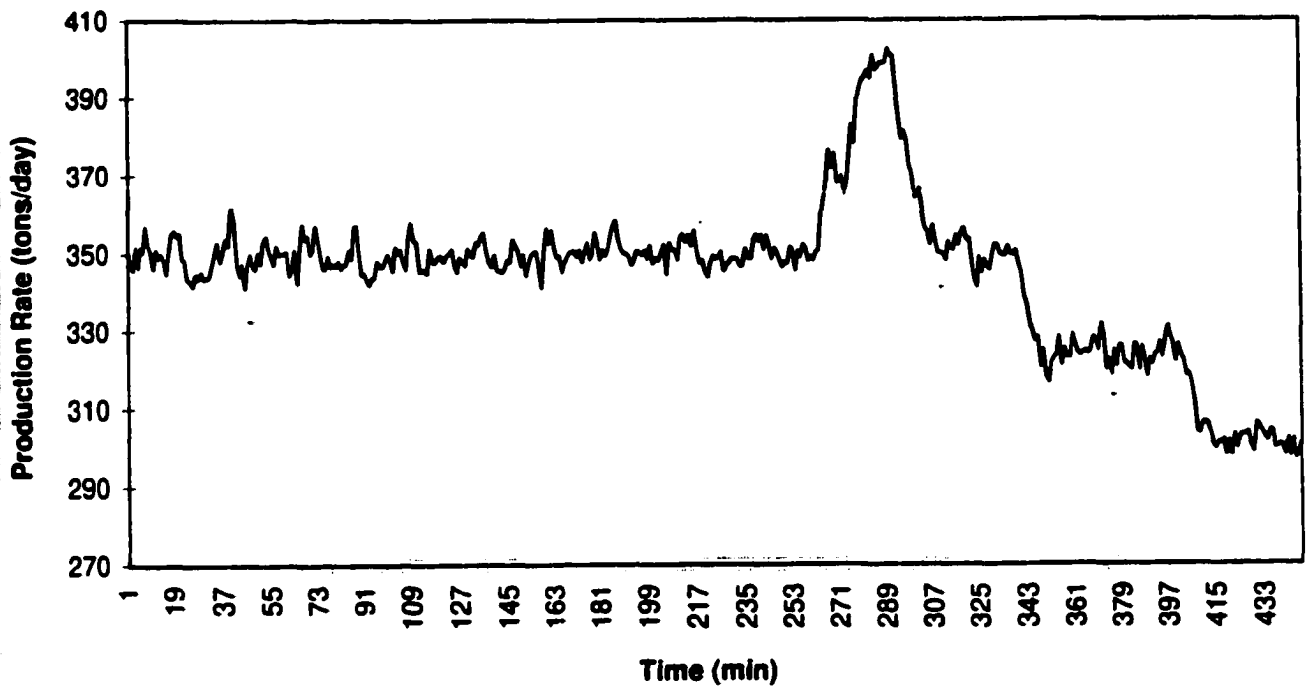

Figure 3.15 Retention Chest Plant Production Rate For the Flotation Inlet Brightness Variation of Figure 3.14

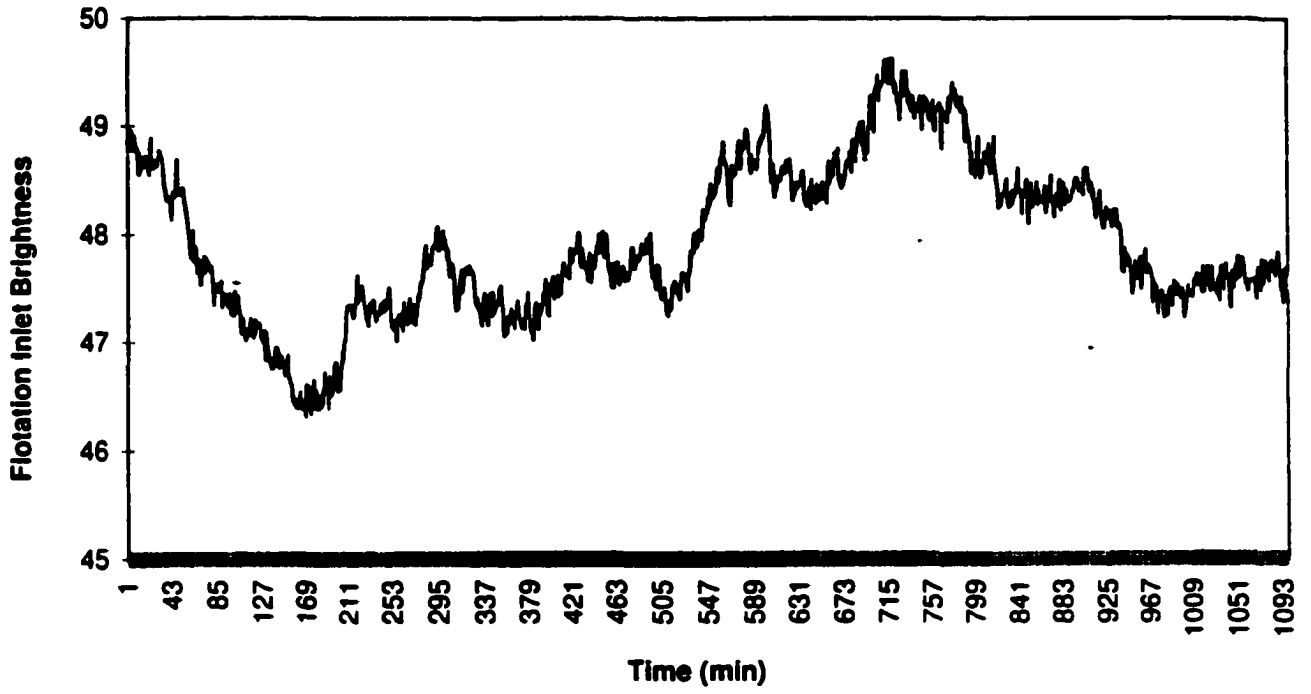

Figure 3.16 Flotation Inlet Brightness Variation For Figure 3.17

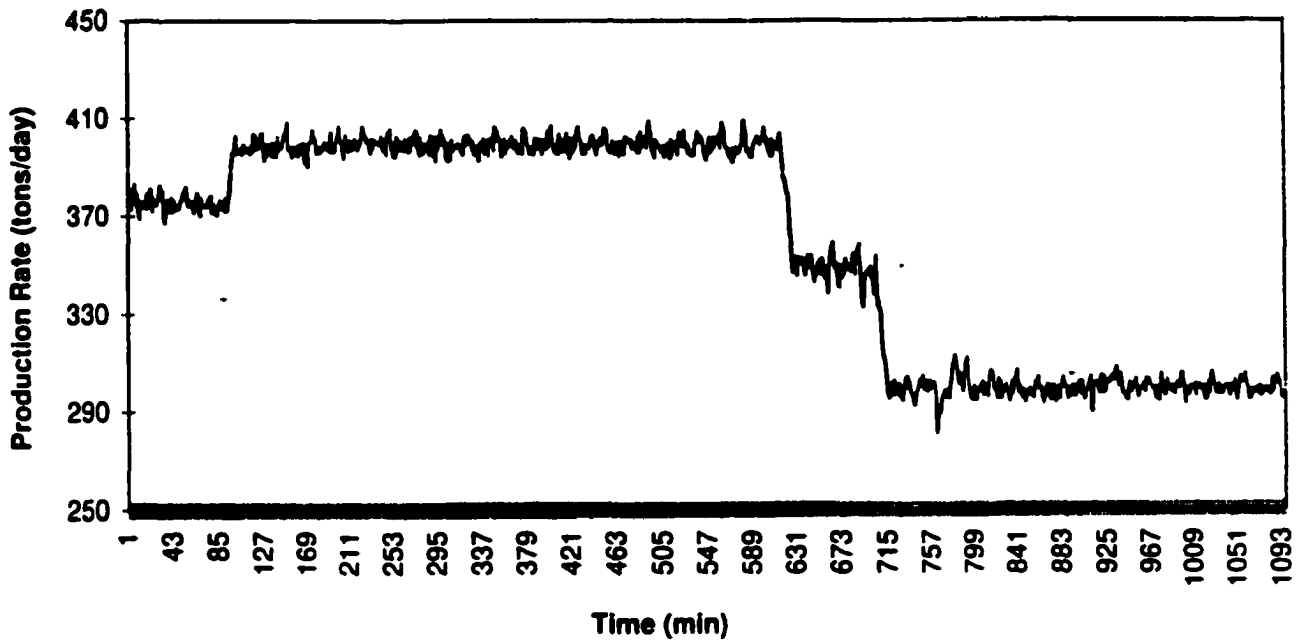

Figure 3.17 Retention Chest Plant Production Rate For the Flotation Inlet Brightness Variations of Figure 3.16

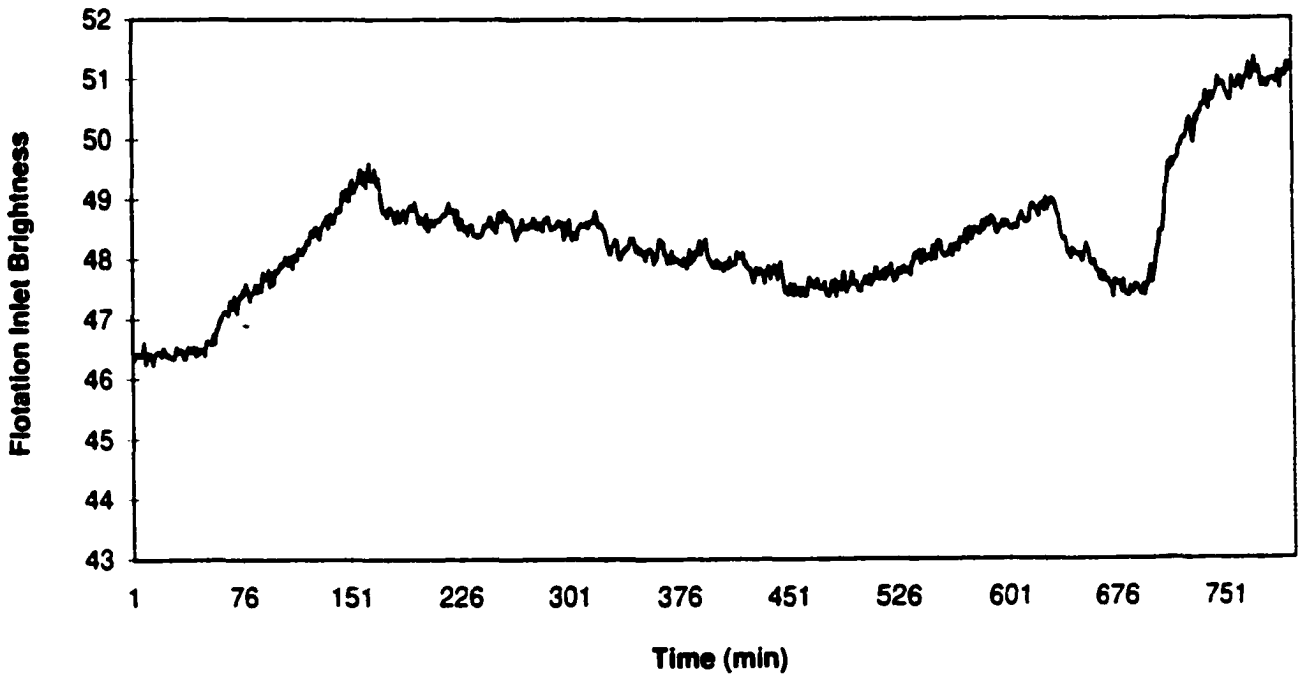

Figure 3.18 Flotation Inlet Brightness Variation For Figure 3.19

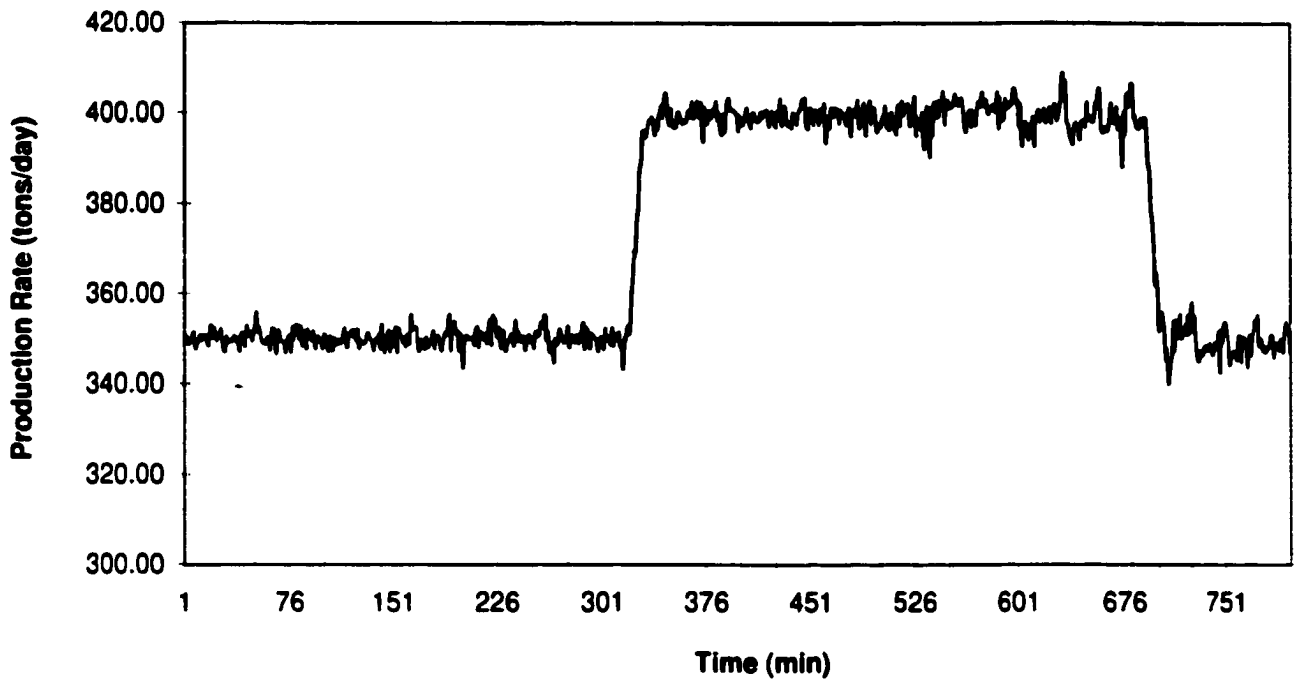

Figure 3.19 Retention Chest Plant Production Rate For the Flotation Inlet Brightness Variation of Figure 3.18

occur during periods of constant production rate and with no correlation to other process variables mentioned earlier. A production rate drop of 350 tons/day at 951 minutes shows no change in pulp brightness, which continues to fluctuate independently of production rate. Additionally, decreases in production rate do not produce sustained increases in pulp brightness. Instead, pulp brightness continues to fluctuate with little correlation to continued changes in production rate. Figures 3.18 and 3.19 shows this pattern of variation in pulp brightness and production rate over an 18 hour period. The coefficient of correlation between brightness and production rate was 0.18. This pattern of behaviour between production rate and pulp brightness demonstrates that a causal relationship between production rate and pulp brightness does not exist. It was suggested that the brightness increases occasionally observed during decreases in production rate were due to a consistency effect on the brightness transmitter [28]. However, during several weeks of regular sampling, no change in consistency was observed when flotation brightness measurements were fluctuating.

No clear relationship between flotation brightness and production rate could be demonstrated. The observed pattern indicates that dropping production rate as a means to compensate for low pulp brightness will not necessarily lead to increases in pulp brightness. Over 80% of the observed brightness variation cannot be attributed to production rate effects, and this brightness variation can be expected to continue despite changes to production rate.

Other process variables were also investigated to determine their relationship to flotation inlet brightness, including the primary and secondary coarse screen rejects rate, grey water pulping temperature, and the primary coarse screen consistency. None of these variables were found to correlate with brightness above 5%. In addition, the grey water makeup flow to the grey water chest was investigated for its relation to flotation brightness. Although the effect of changing makeup water addition to the grey water chest was believed to impact on brightness, no consistent correlation between makeup water flow and flotation brightness could be found above 30%. The variations in makeup water valve position cycle with periods of oscillation ranging from 5-20 minutes. In contrast, the major fluctuations in flotation brightness occur with periods ranging from 45 minutes to several hours in duration. Efforts to improve grey water chest inventory control to reduce the variation of makeup water flow entering the recycle plant are discussed in Chapter 5 with reference to pulper head tank level controls. The impact of improvements in pulper head tank level control on grey water chest makeup water flow and mill brightness variation is addressed in Section 5.2.

As mentioned in Section 1.6, a more controlled experimental plan is necessary to determine the effects of process variables on flotation brightness. With observed batch to batch pulper chemical addition variations of less than 10% of their target values, clear evidence for a correlation between pulp brightness and chemical addition could not be found. The variations of pulp brightness are generally interpreted as arising from the variation in waste paper quality each batch [30]. Visual inspection of the amount of dirt and ink present in feed stock provides a qualitative means for accessing the quality of stock before pulping, and has been used to compensate for low quality stock by increasing chemical dosage use during pulping. However, without a measurement of stock brightness before pulping, the extent to which variations in feed

stock quality are responsible for the observed brightness variation cannot be quantified.

No clear evidence of a correlation between flotation inlet brightness and any of the variables investigated could be found. However, the hydrogen peroxide-sodium hydroxide ratio and the plant production rate both show sufficient evidence to propose a more systematic study of their effect on pulp brightness. Additionally, the significant variation in batch to batch per ton DTPA addition of up to 40% may be a source of brightness variation, although this was not observed on a consistent basis.

In addition to correlation analysis, multivariable regression was also performed on the process data to examine the effect of multiple variables on brightness. Multivariable regression on several runs of 10 hour process data for the combined effects of chemical addition variation, percent magazine addition and plant production rate did not account for more than 40% of the brightness variation. No one variable was found to be consistently responsible for the brightness variation in sampling periods examined. Typically no single variable accounted for more than 25% of the brightness variation in any sampling period, with no combination of variables consistently accounting for more than 40% of the total brightness variation. Generally only one variable displayed significant correlation (>20% correlation) with brightness variation during any sampling period, and therefore single variable correlations were found to be equally effective as multivariable analysis in accounting for the effect of process variation on brightness. No combination of process variables accounted for a significant amount of the brightness variation over several periods of process data. Further use of multivariable statistical analysis techniques to better establish the source of brightness variation was beyond the scope of this thesis. The lack of repeatable correlation between the examined process variables and brightness indicates that the major cause of flotation brightness variation is due to other sources.

Further investigation of the interaction between process variables and pulp brightness should be examined by controlled experimentation to separate the effects of interacting variables, rather than through off-line examination of mill data. The use of factorial design techniques offers the opportunity to study the main and interaction effects of several variables at once, and provides a more direct and systematic means to investigate sources of process variation. The use of evolutionary operation design techniques, whereby continuous changes in process variables are made in a systematic manner which enables identification of variable effects without disturbing process operation. Avenor has began an 11 variable factorial design study to determine the major process variables effecting brightness gain, and has indicated an interest in pursuing this technique for further process investigation [30].

Chapter 4

Feed Forward Control of Pulping Consistency During Batch Pulper Discharge

4.0 Introduction

The concurrent operation of batch pulping operations with the continuous operation of the de-inking and contaminant removal stages causes difficulties when co-ordinating the transfer of pulped stock into the continuous portion of the plant. The large inventory storage available in the retention chest allows for periodic shut down and maintenance in either area of the plant without disturbing operation in the other area. In addition, retention chest mixing helps eliminate large variations in batch to batch pulp quality, and thereby minimizes sudden upsets from changing wastepaper quality entering the continuous portion of the plant.

Consistency control during stock transfer from batch pulping operation to continuous mode operations has exacerbated consistency control problems throughout the recycle plant. During phase 5 of batch pulping operations, stock is discharged from the pulper into the retention chest to begin a new pulping sequence. The discharging pulp is diluted from 10% consistency to 4.5% and fed to the retention chest. However, due to poor control of dilution flow during phase 5, the stock consistency entering the retention varies significantly from 4.5%. These consistency variations appear in the pulp exiting the retention chest, causing sustained oscillations in downstream consistency control loops and poor consistency control. The poor consistency control during phase 5 discharge is not helped by the poor stock mixing in the retention chest, which results in consistency stratifications and stock channelling in the chest. The poor tank mixing enables dilute stock entering the chest towards the end of phase 5 to appear as low consistency pulp downstream. The addition of dilute stock to the retention chest during phase 6 screen back flushing, necessary to minimize stock losses in the Contaminex, also exacerbates consistency control problems.

With adequate mixing in the retention chest, stock consistency variations during phase 5 discharge would not appear downstream. The total addition of grey water during phase 5 and 6 remains properly controlled to ensure an average stock consistency of 4.5%. However, with the current mixing behaviour in the retention chest, variations in retention chest feed consistency cannot be eliminated.

In order to minimize these consistency problems downstream, an improved method for phase 5 consistency control was desired. Figure 4.0 shows the flowsheet for the control problem. During phase 5, dilution water is added to the pulper through under flow controller FC115, and to the pulper discharge line through flow controller FC123. Originally, flow to the pulper and discharge line were simply set at 7500 L/min and maintained until the total dilution water limit for phase 5 was reached. Subsequently, dilution water addition to the pulper was adjusted to minimize pulper discharge time. By beginning pulper dilution water flow later in the

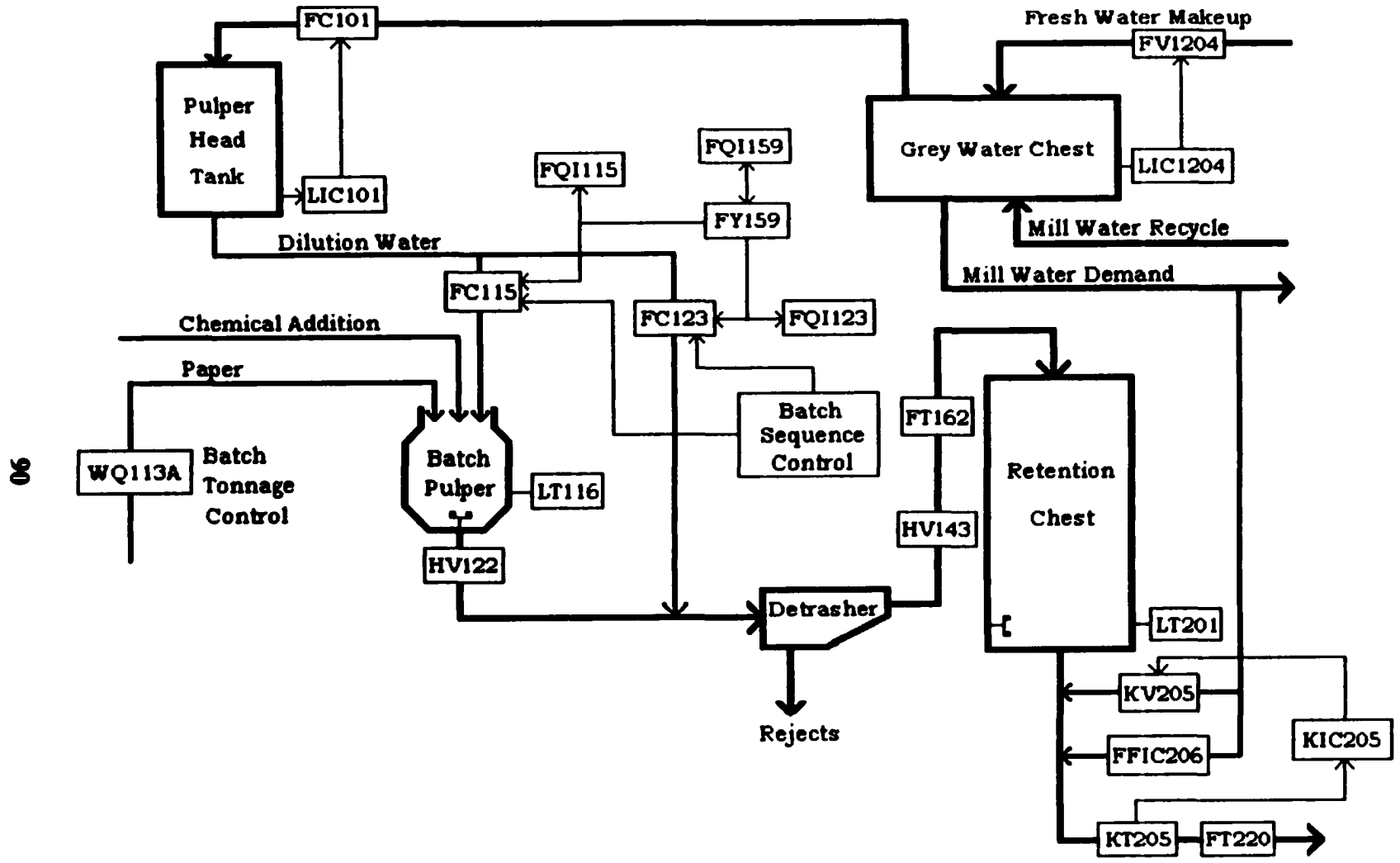

Figure 4.0 Pulper Discharge Process Flowsheet

phase, the extra head pressure from the incoming dilution water significantly reduced total discharge time. Dilution flow to the discharge line was maintained at 7500 L/min from the start of discharge until the grey water limit for phase 5 was reached.

This staged dilution method failed to provide adequate consistency control in phase 5. Consequently, efforts were made to compensate for the high consistency stock appearing early in the phase, and the low consistency stock appearing towards the end of the phase. A flowrate scheme was adjusted to provide 8500 L/min of dilution water from FC123 during the first third of the phase, 7500 L/min during the middle of the phase, and 6000 L/min during the final portion of the phase. Dilution water was also added to the pulper at 7500 L/min during the last half of the phase. However, this procedure did not eliminate the consistency problem.

Simulations performed with process data confirmed the poor consistency control during discharge. Figure 4.1 shows the calculated consistency obtained during phase 5 discharge, assuming an average discharge rate of 9500 L/min. This figure demonstrates Avenor's finding that inadequate dilution during the initial 4 minutes of discharge was causing high consistency stock above 6% to enter the retention chest. Figure 4.1 also shows the beginning of dilution water flow to the pulper after 240s. Because pulper dilution flow begins after the pulper volume has dropped to under 35%, pulper consistency fell rapidly after 220s, falling below the target consistency setpoint of 4.6% at 265s. After this point, the continued flow of dilution water to the pulper over-dilutes the pulper stock to 1.9% consistency by the end of phase 5.

Table 4.0 summarizes the consistency and dilution water addition during phase 5. For the given batch, the total dilution water requirement for phase 5 was 86045 L, while the total dilution water addition for the phase 5 was 56045 L. This constitutes an under dilution by 30004 L, which must be added as makeup with the low consistency stock entering the retention chest during phase 6 detrasher back flushing. The average pulp consistency feeding the retention chest during phase 5 was 5.9%, 28% above the target consistency.

This dilution water shortfall during pulper discharge can exceed 30000 L, depending on the time required to empty the pulper. The discharge time during phase 5 depends on the total batch tonnage and the pressure drop across the Contaminex screens. Batches containing significant amounts of garbage and other contaminants cause partial plugging of the detrasher screens, retarding the flow through the detrasher and increasing discharge time. Additionally, the high consistency stock entering the detrasher during the start of phase 5 often causes excessive screen plugging, thereby reducing discharge flow and increasing phase 5 discharge time. Should the discharge time last longer than expected, most of the phase 5 dilution demand will be added by the end of phase 5. However, when the pulper discharges more rapidly than normal, an excessive amount of dilution water remains to be added after phase 5 ends, as occurred during the batch in Figure 4.1.

This poor consistency control, coupled with the presence of high consistency stock and large contaminants, can lead to complete detrasher screen blockage. When this occurs, the continued addition of dilution water through FC115 and FC123 causes dilution water to back up into the pulper, raising the pulper level to above 90% and setting off the pulper high level alarm. The operators must then manually shut off the dilution water flows, and close the pulper outlet

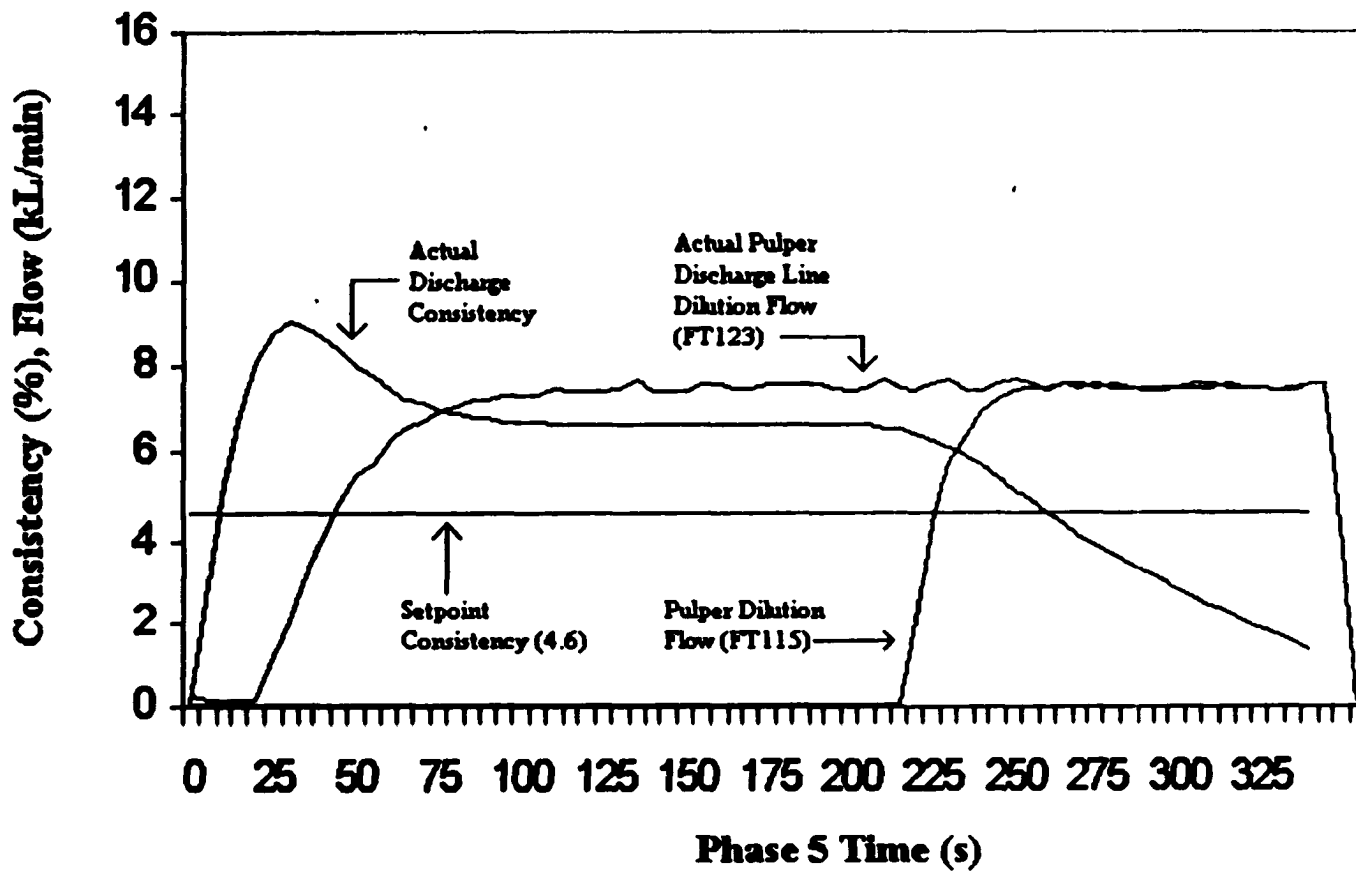

Figure 4.1 Calculated Phase 5 Discharge Consistency Achieved Under Conventional Consistency Control Operation

Table 4.0 Dilution Water Addition Totals for Phase 5 Pulper Discharge

Phase 5 Dilution Water Totals

Calculated Phase 5 Discharge Rate:		= 9500 L/min
Final Phase 5 Discharge Consistency:		= 4.6%
Initial Phase 5 Pulper Consistency:		= 12.0%
Phase 4 Detrasher Pre-Dilution:	FQ123A	= 3100 L
Phase 5 Dilution Water Addition:	FQ123A Phase 5	= 38126 L
	FQ115A Phase 5	= 14815 L
Total Phase 5 Dilution Water Demand:		= 86045 L
Actual Phase 5 Dilution Water Addition:		= 56041 L
Average Phase 5 Discharge Consistency:		= 5.9%
Phase 6 Dilution Water Makeup Demand:		= 30004 L
Phase 6 Makeup Time at 8000 L/min		= 3.75 min

valve and HV143 before back flushing the detrasher screens to clear the blockage. In order to prevent re-plugging during manual discharge, the operators also reduce the valve position on HV143 from 60% to 40% open. The reduced flow through the detrasher enables the rotating blade on the detrasher screens to remove contaminants from the screen mat before plugging can occur. However, this requirement increases the batch time to over 35.0 minutes, reducing plant production capacity below 300 tons/day. During periods of high contaminant levels in the waste paper, the screens can plug every batch.

In order to reduce screen plugging, Avenor has implemented two procedures. To prevent the initial flow of high consistency pulp from plugging the screens before the flow pattern in the detrasher has stabilized, the detrasher was pre-diluted with 3100 L of grey water during phase 4. The extra dilution in the detrasher ensures the initial surge of stock will be stabilized and diluted before reaching the detrasher screens as one solid mass of pulp. In the event of screen plugging problems, the operators reduce the phase 5 detrasher outlet valve position, HV143, from the normal position of 60% open to 40%. The reduced valve position lowers the flow through the Contaminex, enabling the detrasher screens to clear before plugging can occur. Once waste paper contaminant levels return to normal, the detrasher outlet valve position is returned to 60% open during phase 5.

These adjustments have had only partial success in reducing detrasher screen plugging. It was anticipated that improving phase 5 consistency control would help reduce the frequency of detrasher plugging, primarily by preventing surges of high consistency stock from accumulating on the screen surface and causing blockage.

4.1 Consistency Control Problem Formulation

In order to improve control of phase 5 pulper discharge consistency, a feed-forward dilution water control strategy was proposed to control grey water dilution flowrates FT115 and FT123 during phase 5.

With reference to Figure 4.0, a material balance for pulp stock around the detrasher, modelled as a continuously stirred tank, gives:

$$d(V_D * C_s)/dt = F_1 * C_p + F_2 * C_{grey} - (F_1 + F_2) * C_s \quad (4.1)$$

- where
- 1) V_D = Detrasher Volume, L
 - 2) C_s = Consistency in Contaminex Detrasher feeding the Retention Chest
 - 3) C_{grey} = Grey Water Dilution Consistency, (0.02%)
 - 4) C_p = Pulper Discharge Consistency, variable
 - 5) F_1 = Pulper Discharge Flowrate, kg/min
 - 6) F_2 = FC123 grey water dilution flowrate, kg/min

Solving for F_1 at steady state gives the required grey water dilution flow (FT123) for proper consistency control:

$$F_2 = F_1 * (C_s - C_p) / (C_{grey} - C_s) \quad (4.2)$$

C_s is the phase 5 setpoint consistency target, 4.5%. Determination of this flowrate requires estimation of the pulper discharge flow F_1 and the pulper stock consistency C_p as a function of time. The addition of grey water dilutes the pulper stock and must be calculated throughout phase 5. Additionally, the pulper discharge flow varies between batches as a consequence of the changing head pressure and stock consistency in the pulper.

The pulper can be modelled as a continuously mixed tank during phase 5 discharge. Pulper stock is sufficiently agitated by the tank impeller to approximate ideal mixing. A material balance for the pulp stock across the pulper gives:

$$d(V_p * C_p) / dt = -F_1 * C_p \quad (4.3)$$

where the pulper dilution water consistency was taken to be zero and

- V_p = the current volume of stock and water in the pulper
- F_1 = the pulper discharge flowrate, L/min
- C_p = pulper stock consistency

A material balance for the pulper dilution water gives:

$$d(V_p * (1 - C_p)) / dt = FT115 - F_1 * (1 - C_p) \quad (4.4)$$

Solving for F_1 and substituting into Equation 4.2 gives the consistency change in the pulper:

$$dC_p / dt = -FT115 * C_p / [V_p * (1 + C_p / (1 - C_p))] \quad (4.3)$$

The consistency in the pulper can then be calculated as a function of time using a discrete time Euler integration of Equation 4.3, shown below.

$$C_{pt2} = C_{pt1} + [-FT115_{t1} * C_{pt1} / [V_{pt1} * (1 + C_{pt1} / (1 - C_{pt1}))]] * (t_2 - t_1) \quad (4.5)$$

The consistency change in the pulper during phase 5 pulper dilution and discharge was simulated to determine the sensitivity of step size for a discrete integration of Equation 4.5. Time Step sizes of 0.5, 2.0 and 4.0 s were used to simulate the consistency profile in the pulper. The difference in

calculated consistency with the three step sizes differed by less than 2%. Therefore a step sampling time of 4.0 s was determined to be adequate to calculate the pulper consistency change during discharge.

In order to calculate the correct dilution flow from Equation 4.2, the pulper discharge flow must be determined. As shown in Figure 4.0, an ultrasonic flowmeter FT162 is installed on the discharge line to the retention chest. This in conjunction with FC123 would enable a direct calculation of the pulper discharge flow. Unfortunately, this flow transmitter was determined to be unreliable, and consequently could not be used for flow measurement. Instead, pulper discharge flow was determined from the pulper level transmitter LT116, by empirically relating the pulper level to the total volume of stock in the pulper. During phases 1,2 and 4 of the batch pulping cycle, the total dilution water added to the pulper can be measured and used to relate total pulper dilution water inventory to the pulper level throughout the batch cycle. The data was used to determine an empirical relationship between pulper level and total pulper inventory. As Figure 4.0 shows, the pulper tank diameter decreases towards the bottom of the pulper. This pulper geometry was accommodated by using a quadratic rather than linear relationship between pulper level and total inventory. Linear regression on similar process data demonstrated the following equation related the total inventory in the pulper head tank to the pulper level within 5%.

$$V_p = 3.24*(LT116_F)^2 + 598.8*(LT116_F) \quad (4.6)$$

where LT116_F is the measured pulper level in percent. Additionally, comparison of Equation 4.6 with other pulper filling cycles demonstrated a good fit of the data throughout the full range of pulper level changes. Equation 4.6 was calculated for a zero y-axis intercept to ensure zero pulper inventory when the pulper was empty.

Figure 4.2 shows the change in pulper volume during phase 5 discharge. Control valve HV143 opens approximately 45.0 seconds into phase 5 to enable the pulper to begin discharging. The pulper volume continued to drop at an approximately steady rate until the addition of pulper dilution water, FT115, begins some 220 seconds into the phase. Figure 4.2 indicates the possibility of calculating the pulper volume change from the pulper level. Calculation of the pulper discharge flow rate using Equation 4.7 then enables calculation of the required dilution flow FT123 by Equation 4.2.

$$dV_p/dt = FT115 - F_i \quad (4.7)$$

During phase 4, the Contaminex detrasher is prediluted with 3100L of grey water to minimize screen plugging during the initial period after pulper discharge begins. The stock entering the retention chest during this period is consequently of low consistency until a sufficient amount of pulper stock enters the detrasher and mixing with the dilution water. It was desired to estimate the time required for the consistency in the detrasher to reach the target consistency setpoint before beginning grey water dilution through FC123. This would minimize the volume of low

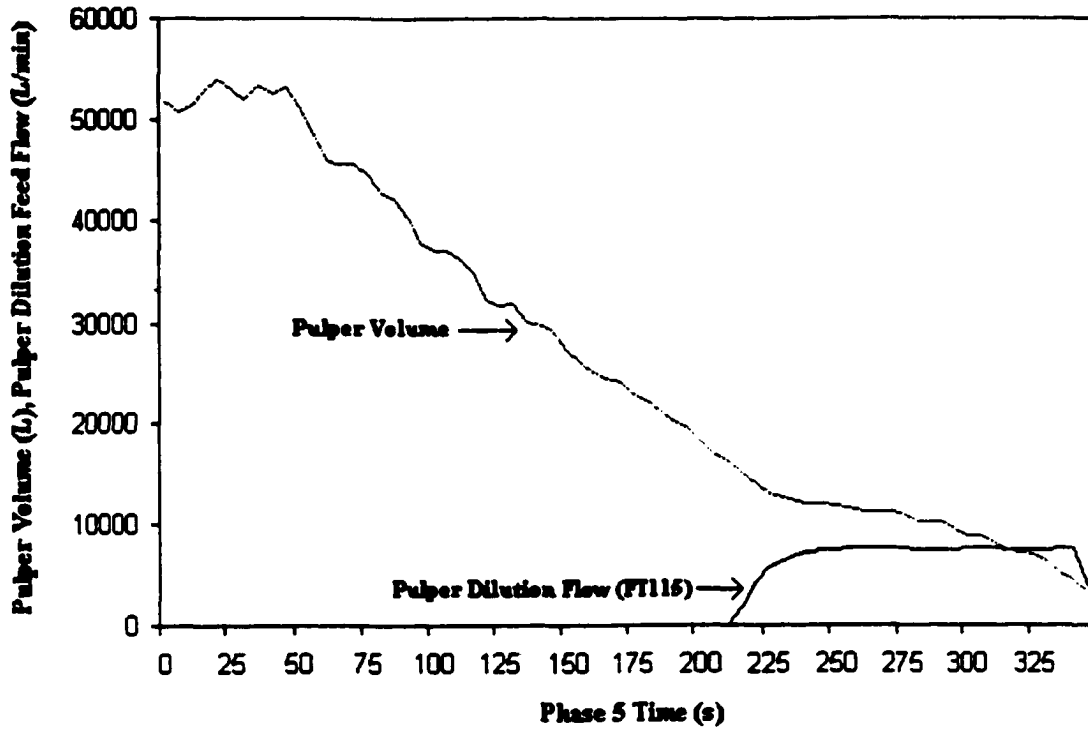

Figure 4.2 Change in Pulper Volume During Typical Phase 5 Discharge Operation

consistency stock entering the retention chest during the initial period after discharge begins. To determine this detrasher time, the detrasher was modelled as a continuously stirred tank. Referring to Equation 4.1, and assuming a grey water consistency of zero, a pulp balance on the detrasher gives,

$$dC_d/dt = (F_1/V_D) * C_p - ((F_1+F_2)/V_D) * C_d \quad (4.8)$$

Assuming an initial detrasher consistency of 0% at t=0 and setting F₂ to zero gives upon integration of Equation 4.8:

$$t_{C_d} = (1/K_2) * \ln(K_1/(K_1 - K_2 * C_d)) \quad (4.9)$$

where $K_1 = F_1 * C_p / V_D$

$K_2 = F_1 / V_D$

$V_D = 3100 \text{ L}$

$C_p = 12\%$

t_{C_d} = time for pulper discharge flow to raise detrasher consistency to 4.5%

The time for detrasher consistency to reach 4.5% for varying pulper discharge flowrates are summarized below:

F ₁ (L/min)	6000	7500	8500	9500	11000
Time (s)	15.0	12.0	10.6	9.5	8.2

Varying the pulper discharge consistency (C_p) between 10-14% did not significantly change the detrasher time. Assuming an initial discharge rate of 9000 L/min, a comparative plug flow model gives a detrasher time of 21 s. Therefore, a 10.0 s time delay before beginning FC123 grey water dilution was chosen to accommodate the likely range of discharge flowrates, pulper consistencies and lag times in FC123 dilution valve setpoint response.

4.2 Pulper Discharge Consistency Control Implementation

The control system was implemented as the dependent sequence block RN_PULPER:PULPER_CONS.s on the Unix based Distributed Control System in the recycle plant. The implemented sequence code is shown in Appendix B, and discussed below.

The pulper discharge consistency block controls the phase 5 addition of grey water dilution by flow controllers FC115 and FC123, as shown in Figure 4.0. The consistency controller was implemented to achieve the following objectives:

1. Calculate the pulper consistency during phase 5, shutting off pulper dilution flow FC115 when the pulper consistency reaches 4.5%, thereby preventing stock over-dilution.
2. Calculate the stock discharge flow rate exiting the pulper. Use this flow to regulate dilution flow FC123 to control pulp consistency feeding the retention chest.
3. Monitor and display the total addition of grey water during phase 5. Upon addition of the required grey water demand, the control block must shut off dilution flows FC123 and FC115.
4. Provide window displays through the Distributed Control system to permit operator monitoring and interaction with the control block. The operators must be able to switch between standard and supervisory consistency control modes.

The control block algorithm is summarized below.

- 1.0 a) Variable Initialization. Assume an initial pulper discharge rate of 4000 L/min until on-line sampling in phase 5 permits direct measurement of the discharge flow.
- 2.0 <<DIL_LOOP>>
- 3.0 If the current Phase number is 3:
 - a) Re-initialize block variables for phase 5
- 3.0 If the current Phase number is 4:
 - a) Measure the total addition of grey water to the detrasher.
 - b) Calculate the detrasher time (DETR_TIME) from the volume of grey water added to the detrasher during phase 4.
 - c) Calculate and store the final phase 4 pulper consistency.
- 4.0 If the current Phase number is 5:
 - a) If the phase 5 consistency control block is in supervisory mode, activate the operator screens to display the grey water dilution water totals during phase 5.
 - b) Turn on timer PH5_TIMER at the start of phase 5.
 - c) Determine if the pulper outlet valve and detrasher line outlet valve (HV143) are

open. If both valves are open for the first time, then the pulper has began discharging. Store the time in phase 5 at which pulper discharge to the detrasher began. Using this time, calculate the phase 5 time at which pulper dilution flow FC123 should begin to compensate for grey water pre-dilution in the detrasher.

- d) From the pulper level measurement LT116, calculate the volume of stock in the pulper (Equation 4.6); store this volume in the array PULP_VOL.
 - e) Using the last 25 seconds of pulper volume data, calculate the rate of volume change in the pulper.
 - f) From the volume change in the pulper and the pulper feed flow FT115, calculate the pulper discharge flow (DISCHG_FL) from Equation 4.7.
 - g) Calculate the consistency change in the pulper by Equation 4.5. If the consistency is within 10% of the setpoint consistency, shut off FC115 to prevent pulper over-dilution.
 - h) From the calculated pulper discharge flow and pulper consistency, calculate the required dilution flow, FT123, by Equation 4.2.
 - i) Determine if the detrasher time delay on FC123 dilution has been exceeded.
 - i) If No, Set FC123 to 0.0.
 - ii) If yes, output the calculated FC123 setpoint demand to the flow controller.
 - h)
 - i) Calculate the total amount of grey water added in phase 5 from flow accumulators FQ115A and FQ123A. If the accumulated grey water addition exceeds 97% of the phase 5 grey water demand total, shut off FC115 and FC123 dilution flows.
 - ii) From the calculated pulper consistency and the volume of stock remaining in the pulper, calculate the volume of dilution water required to dilute the remaining stock to setpoint consistency. Calculate the correction factor CORR necessary to compensate for the excess addition of grey water through FC123. Use CORR during the the next batch to partially compensate for the excess grey water addition in phase 5.
- 5.0 a) If phase 5 pulper discharge has finished, compare the total addition of grey water to the phase 5 grey water demand. If the total grey water

addition is less than the phase 5 demand requirements, increase the flowrate of grey water from FC123 during the next batch to compensate the inadequate grey water addition. If the total grey water addition exceeds the phase 5 grey water requirement, reduce the average dilution flow from FC123 during the next batch to avoid exceeding the phase 5 grey water demand limit.

b) Return the operator console displays to standard mode.

6.0 a) Determine if the consistency control block is in supervisory mode:

- i) If no, wait until control returns to supervisory mode and the batch cycle returns to phase 1.
- ii) If yes, goto step 7.0

7.0 Wait 4.0 s (Sampling time); GOTO step 2.0.

4.3 Results and Discussion

The implementation of the consistency control block has significantly improved consistency control in the retention chest. The improvement in consistency control can be measured by the variation in the retention chest outlet consistency dilution valve position, and by the measured consistency variation after dilution. Figure 4.3 shows the original variation in the consistency control valve position over a typical 8 hour period. The control valve position oscillates throughout each batch in response to the addition of stock to the retention chest. The variation in control valve position is a direct measure of the consistency variation of stock exiting the retention chest. It is the large variation in retention chest consistency, caused by poor control of pulper discharge consistency, that causes the regular cycling of the retention chest outlet consistency control valve position. The addition of heavy stock during the initial period of phase 5 discharge, and the subsequent addition of dilute stock towards the end of phase 5 and into phase 6 (see Figure 4.1), is responsible for the cyclical variation in stock consistency each batch. The drop in control valve position during phases 6 and 7 is caused by the presence of low consistency stock entering the retention chest during the phase 5 and 6. During Phase 6, approximately 8000 L of dilution water is added to the retention chest after use in flushing the detrasher screens. This extra dilution water is necessary to prevent excessive stock loss in the detrasher screens. However, the very low consistency of this stock causes the periodic drop in retention chest outlet dilution valve position after the phase 6 cycle finishes. Figures 4.4 and 4.4a show the plant production rate behaviour associated with this variation in retention chest stock consistency. Poor consistency control causes cyclic variations in downstream consistency control loops, and acts a production disturbance to downstream screening and flotation stages.

Figures 4.5 and 4.6 show the improvement in consistency control under pulper discharge

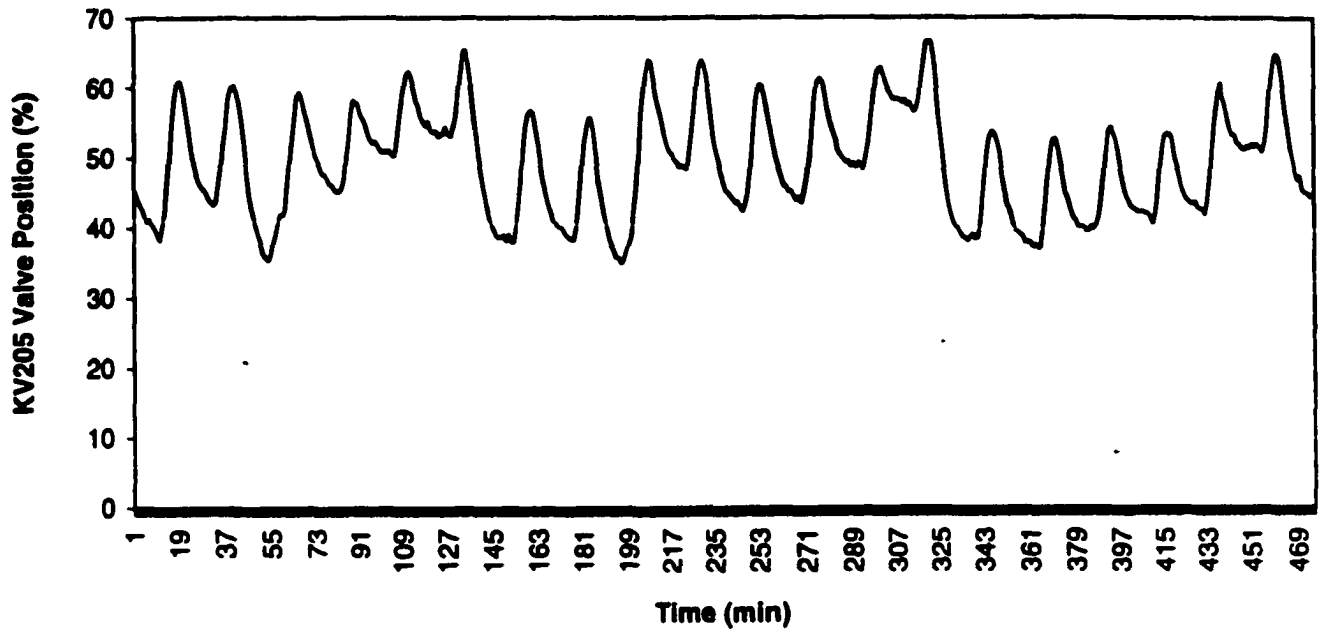

Figure 4.3 Retention Chest Outlet Minor Consistency Control Valve Position Under Conventional Pulper Discharge Consistency Controls

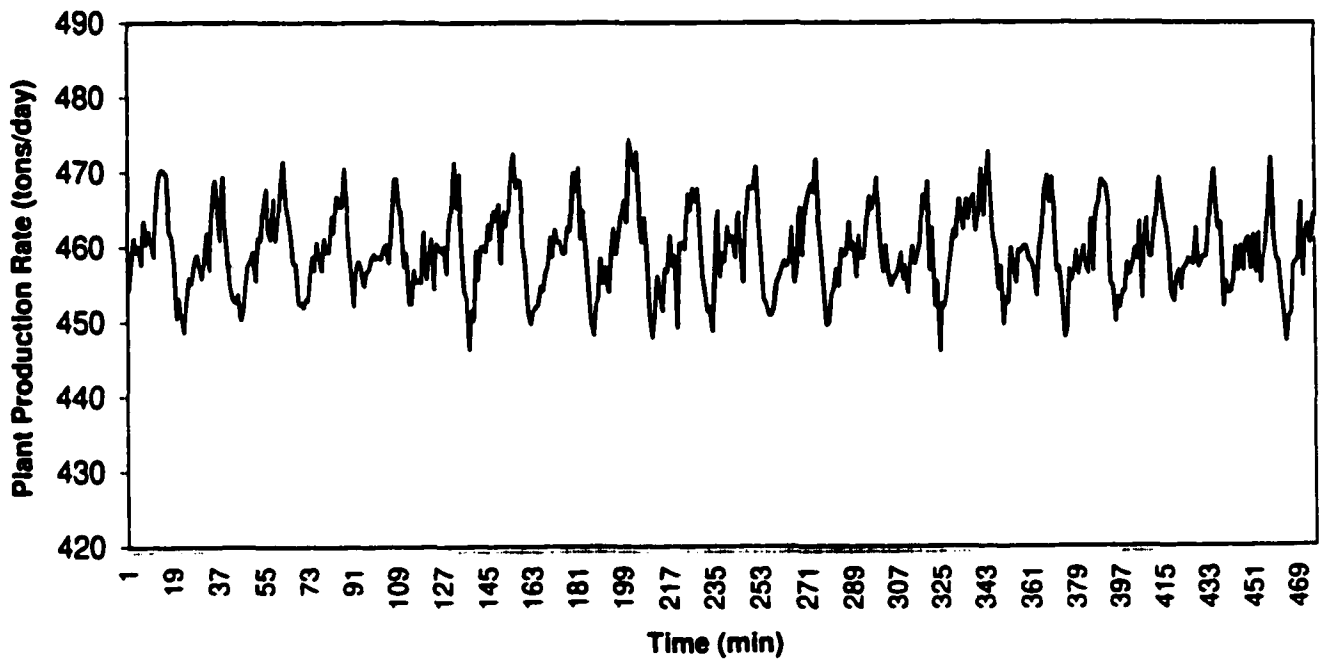

Figure 4.4 Retention Chest Production Rate Variation Under Conventional Pulper Discharge Consistency Controls

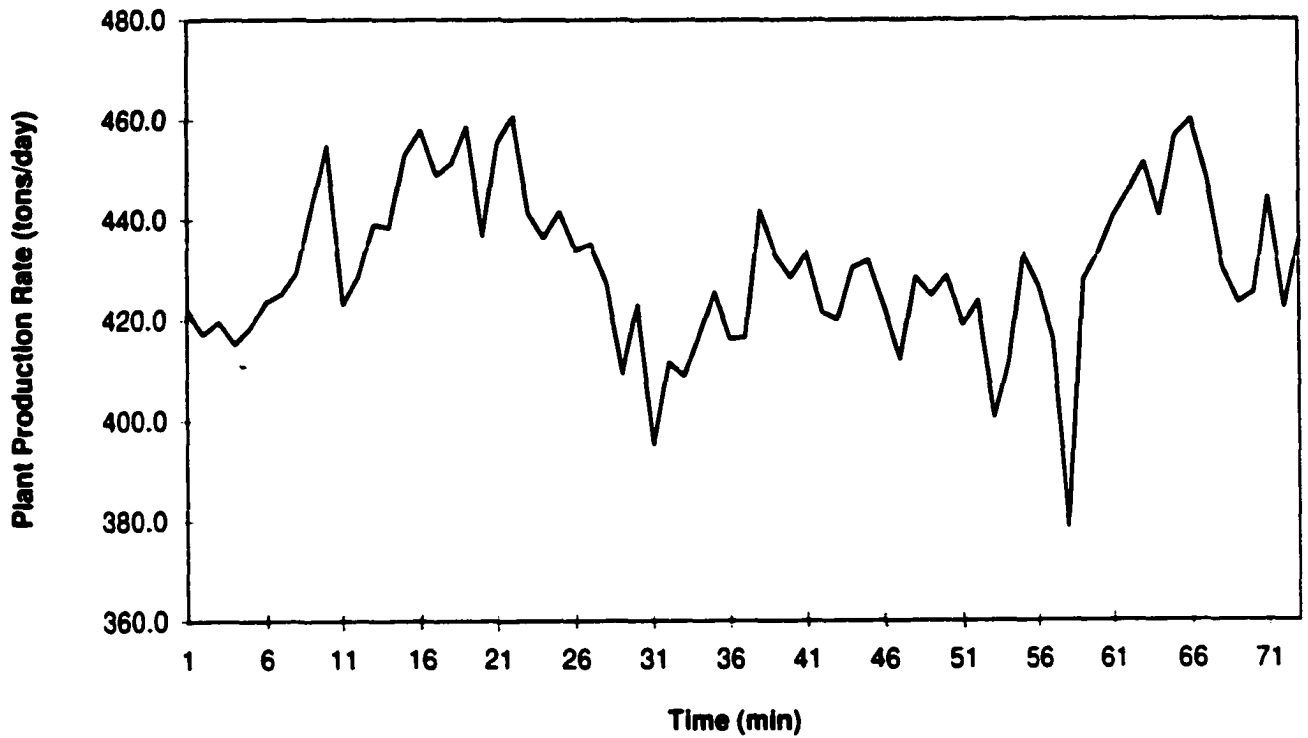

Figure 4.4a Production Rate Variation Problems Under Conventional Consistency Control

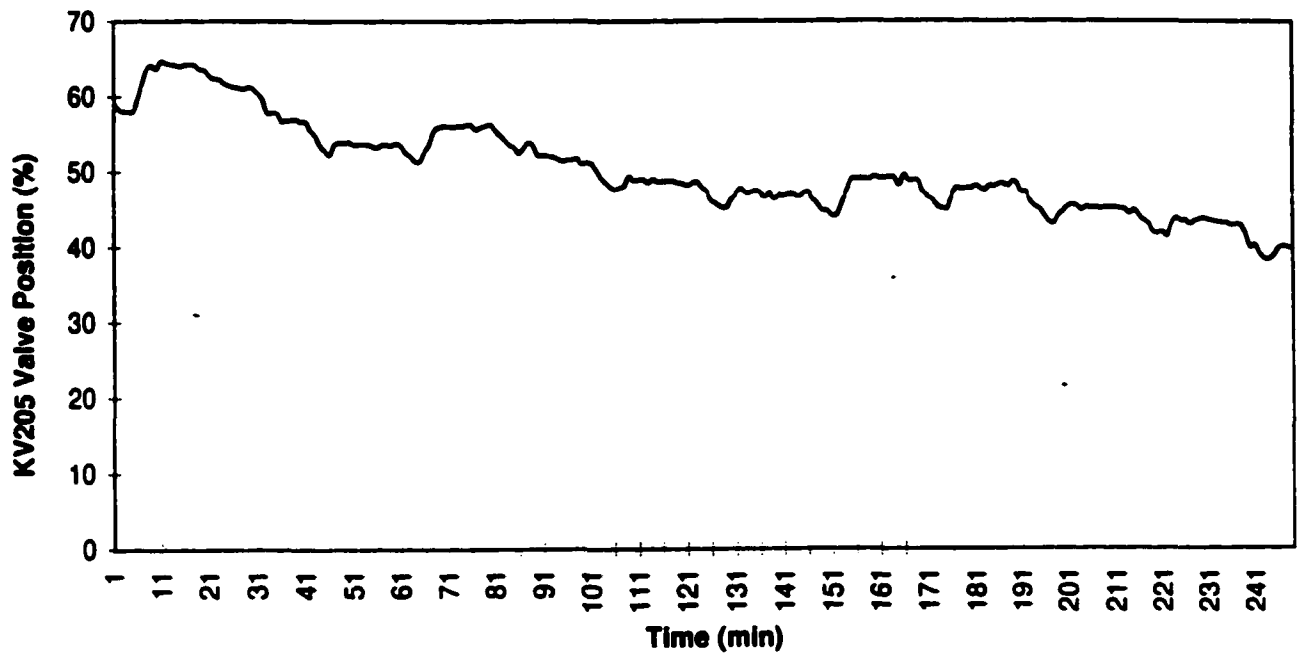

Figure 4.5 Retention Chest Outlet Minor Consistency Control Valve Position Under Supervisory Pulper Dilution Consistency Control

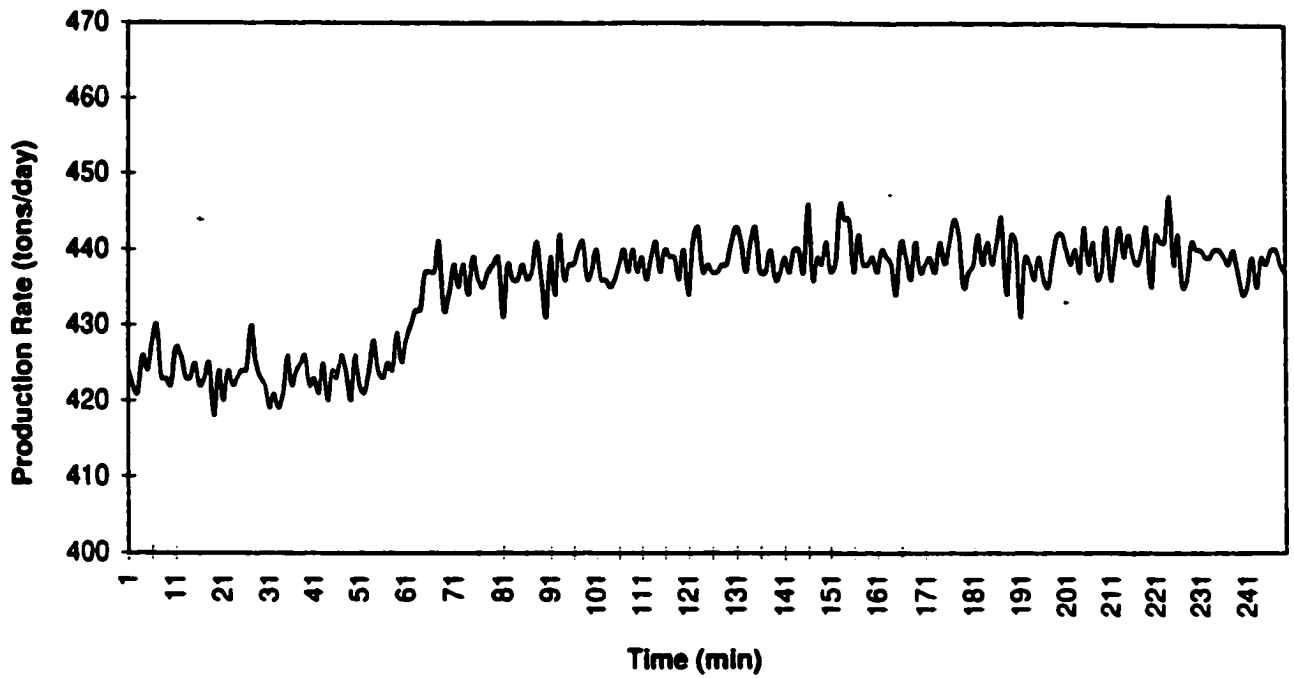

Figure 4.6 Retention Chest Production Rate Variation Under Supervisory Pulper Dilution Consistency Control

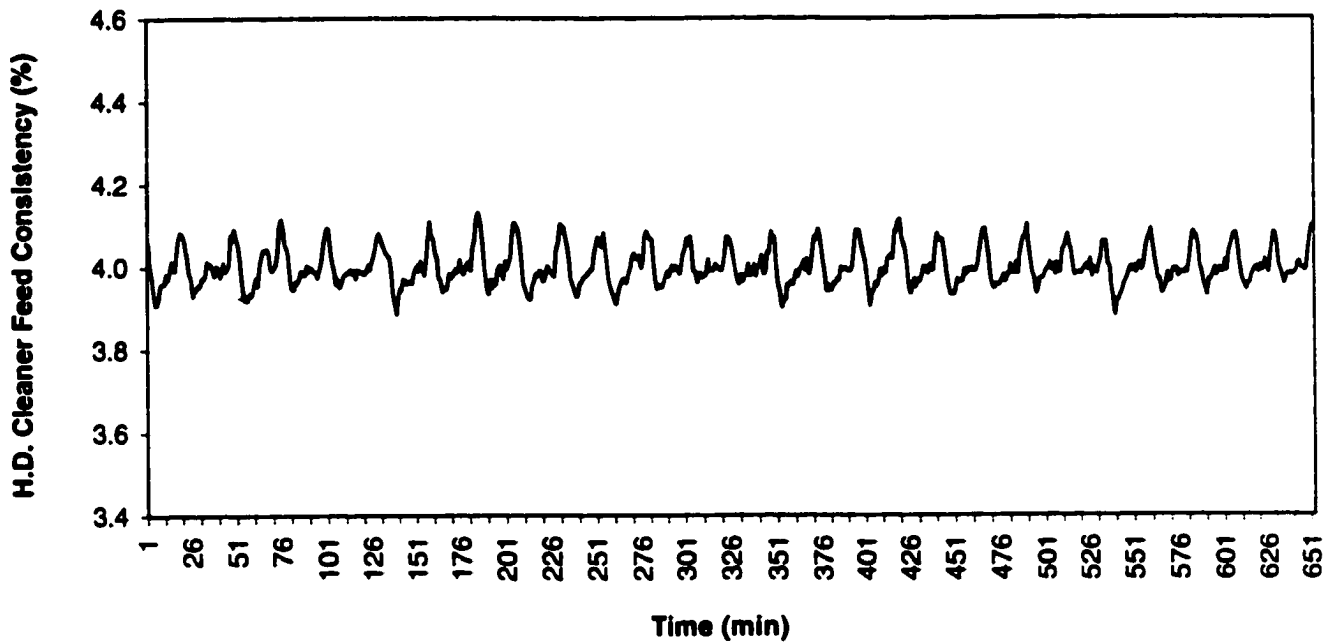

Figure 4.7 High Density Cleaner Feed Consistency Variation Under Conventional Pulper Discharge Consistency Control

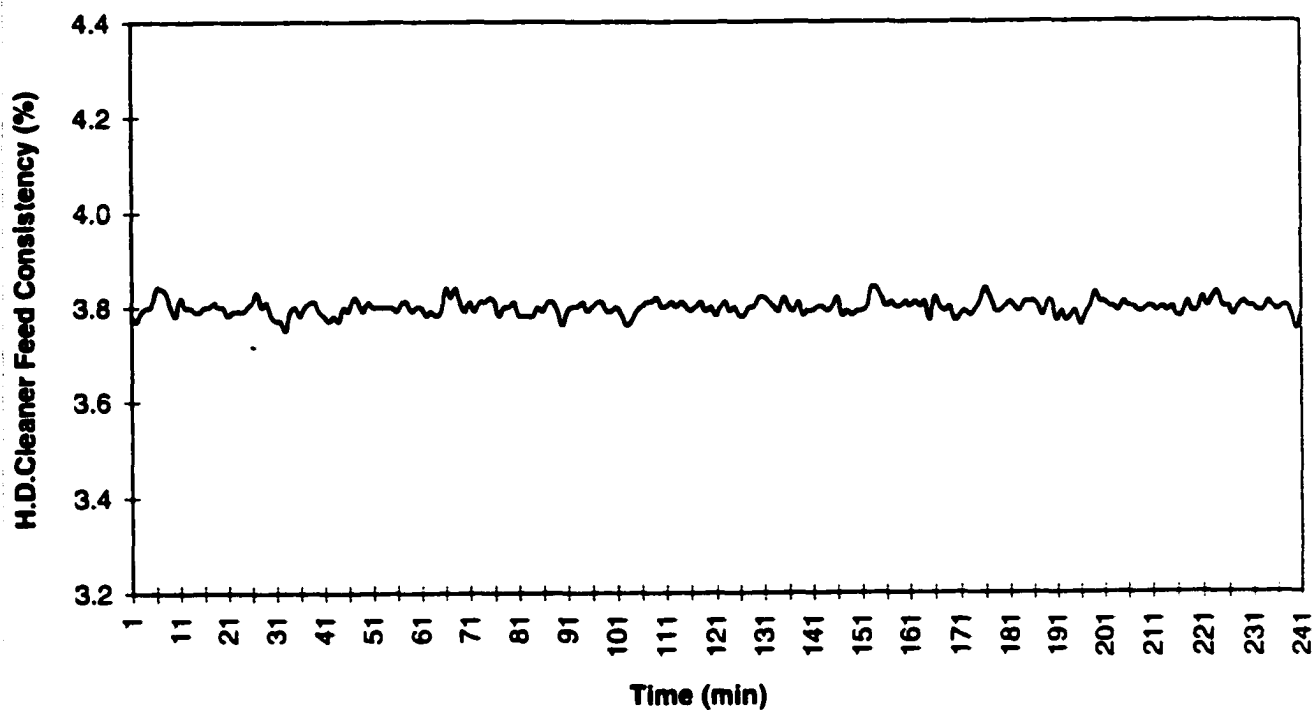

Figure 4.8 High Density Cleaner Feed Consistency Variation Under Pulper Supervisory Pulper Dilution Consistency Control

Table 4.1 Consistency Control Performance Under Supervisory and Conventional Controls

	Variance		Percent Change
	Conventional	Supervisory	
Retention Chest Outlet Minor Dilution Valve (KV205)	59.0	5.0	-91%
Retention Chest Production Rate	63.0	8.0	-87%
H.D. Cleaner Inlet Consistency (KIC205)	3.2×10^{-3}	2.2×10^{-4}	-93%
Batch Time	9-10 minutes	7-8 minutes	-20%

consistency control. The variance in the consistency dilution valve position has been reduced by 88%, and the maximum oscillation in control valve position during phase 5 has been decreased from 20% to under 5% of full scale. As shown in figures 4.7 and 4.8, the resultant consistency variation at the high density cleaner inlet has been reduced by 90%.

In addition, process operators have reported a significant decrease in the frequency of detrasher plugging problems [31], verifying that improvements in discharge consistency control has improved detrasher screening operation.

Table 4.1 summarizes the changes to retention chest consistency control after implementation of the pulper discharge consistency control block. The variance in KV205 position has been reduced by 88%, with corresponding reductions in the variance of the plant production rate and high density cleaner inlet consistency of 77% and 91%.

Figures 4.9-4.13 shows the behaviour of the consistency controls during phase 5. In addition to improved consistency control, phase 5 discharge time has been reduced from an average time of 10 to 7 minutes, which corresponds to a 20% reduction in batch time.

Figure 4.9 shows the pulper level change throughout the batch. Figure 4.9 shows that pulper discharge begins 46 seconds into phase 5, with discharge line dilution flow beginning 10 seconds after discharge begins to accommodate detrasher pre-dilution water from phase 4. Figures 4.11 and 4.12 show the pulper dilution water flow and the consistency in the pulper during phase 5. Dilution flow to the pulper begins at 160 s and continues until the pulper

consistency drops to 4.5%. Figure 4.13 shows the calculated phase 5 discharge consistency achieved during phase 5.

The major sources of error associated with the consistency control block include errors from the calculated pulper discharge flow, and offset between the discharge line setpoint flow and the output flow. Calculation of the discharge flow depends upon the accuracy of the level transmitter and pulper dilution flowmeter. Due to the greater accuracy attainable from calculating the pulper volume rather than the rate of change in pulper volume, and the better mixing available from the pulper impeller rather than in the discharge line, obtaining more phase 5 dilution in the pulper will improve consistency control. Currently, the pulper dilution addition begins approximately half way through phase 5. Beginning pulper dilution earlier in phase 5 would allow for greater dilution in the pulper, thereby reducing the demand on FT123 and improving stock-dilution water mixing.

Discharge consistency control could also be improved by better control of the batch tonnage with respect to the plant production rate. Currently, batch tonnage is typically set at 6.3 tons or more. For a batch time of 18 minutes, this corresponds to 504 tons/day. Because of the high batch tonnage, phase 4 pre-dilution is typically limited to 12% consistency to prevent exceeding pulper level constraints. However, with a plant production rate of 400 tons/day, this high batch tonnage is not required to maintain retention chest inventory, and must be accommodated by pausing between batches. By proportioning the batch tonnage to the long term plant production rate, lower batch tonnages could be obtained, which in turn allows for greater phase 4 pulper pre-dilution, and greater phase 5 dilution in the pulper.

Offset between the FT123 dilution flow setpoint and output dilution flow also impact on consistency control. The maximum dilution flow from FT123 is limited to 15000 L/min. However, with pulper consistencies above 10% or discharge setpoint consistencies below 4.5%, the initial dilution water demand FT123 can be greater than 18000 L/min. Therefore, should the setpoint dilution demand rise above 15000 L/min, the dilution flow will be unable to achieve the desired discharge consistency. The control valve for FT123 is currently limited to a maximum opening of 60% full span, and should Avenor choose to increase the maximum valve position, further improvements in consistency control could be obtained during the initial period of phase 5.

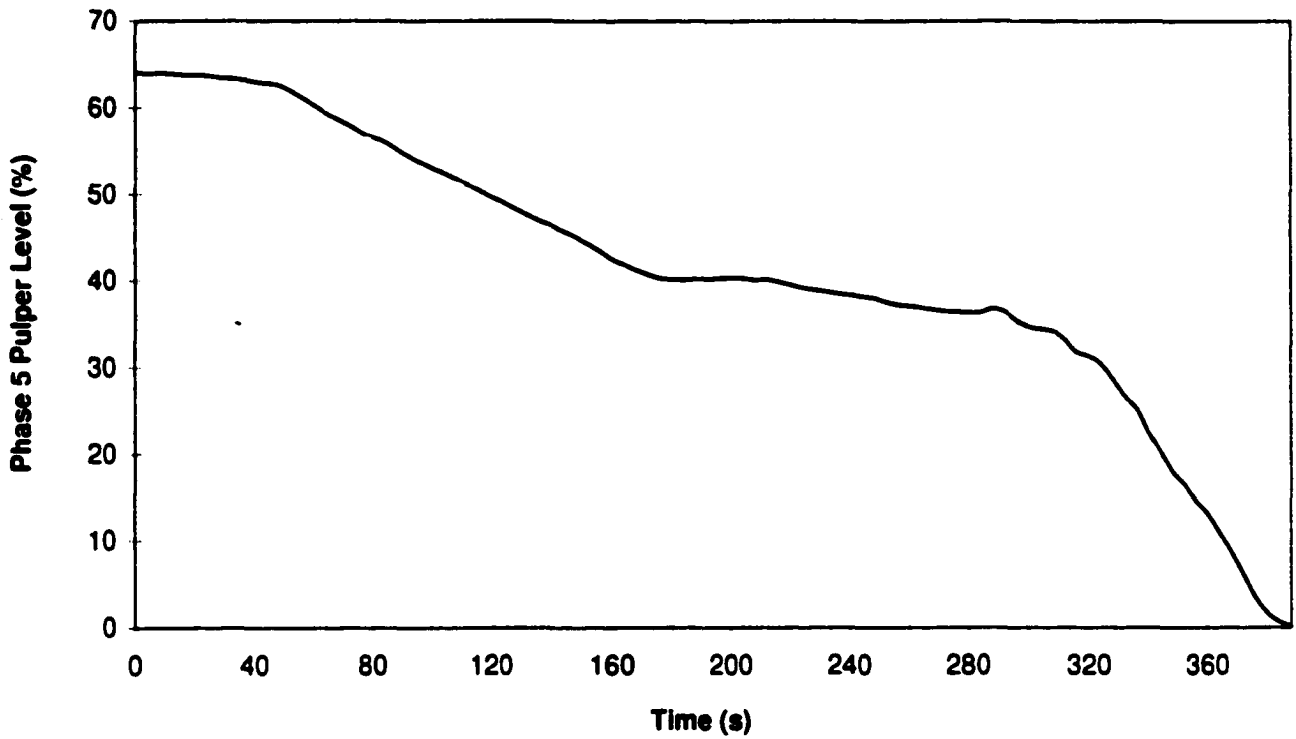

Figure 4.9 Pulper Level Change Under Supervisory Pulper Dilution Control

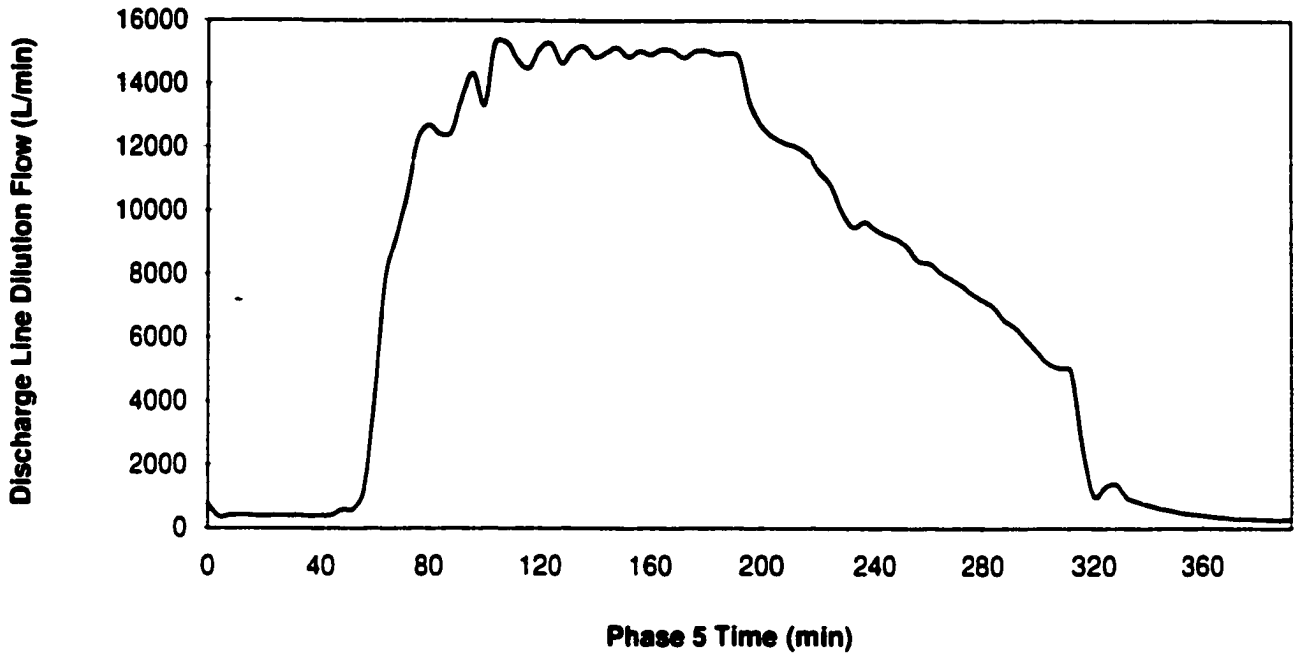

Figure 4.10 Phase 5 Discharge Line Grey Water Dilution Flow (FT123)

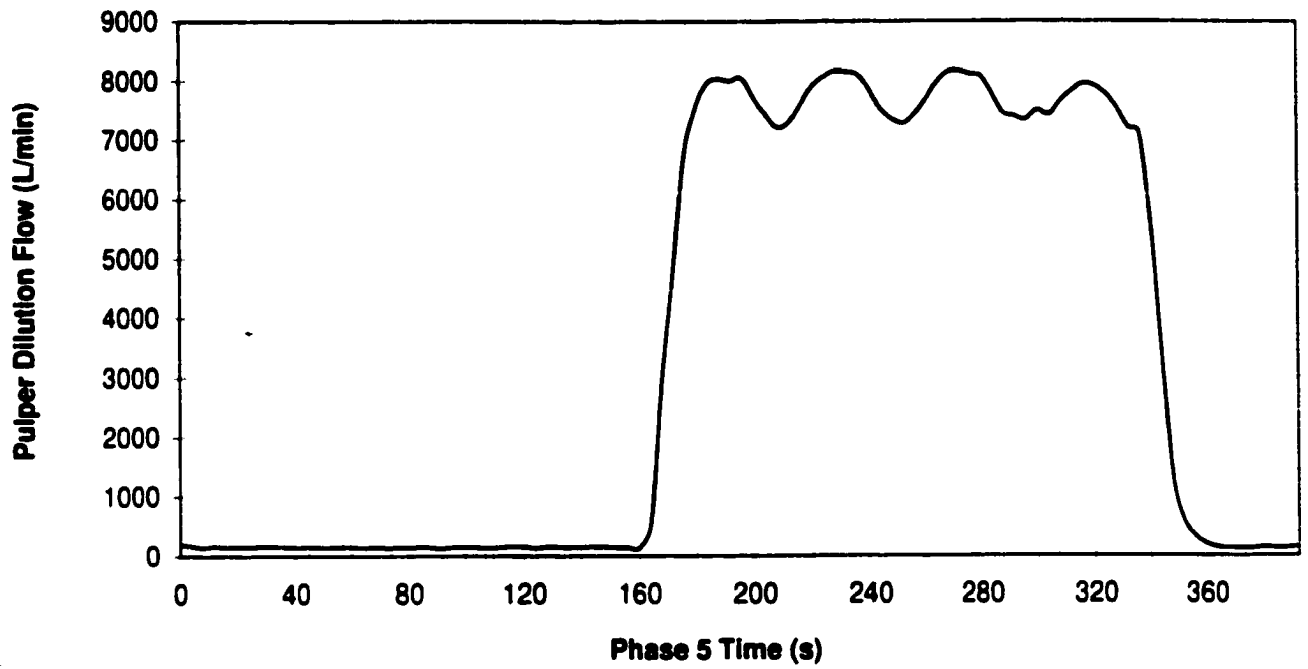

Figure 4.11 Phase 5 Pulper Dilution Flow (FT115)

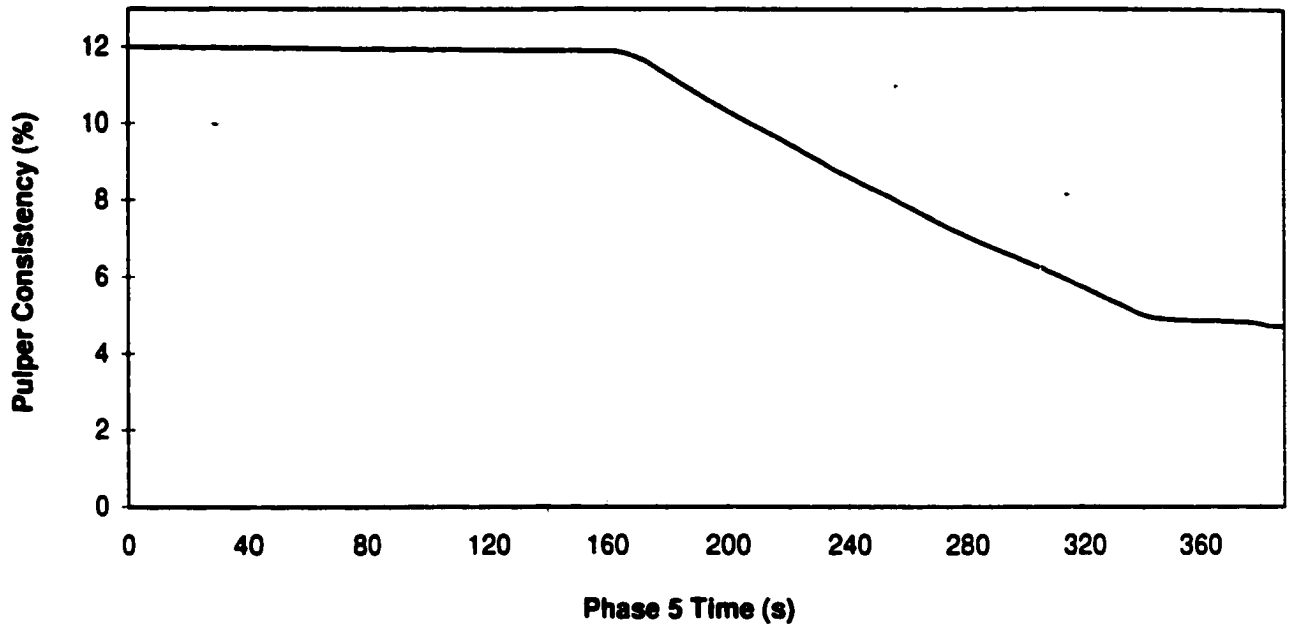

Figure 4.12 Calculated Phase 5 Pulper Stock Consistency

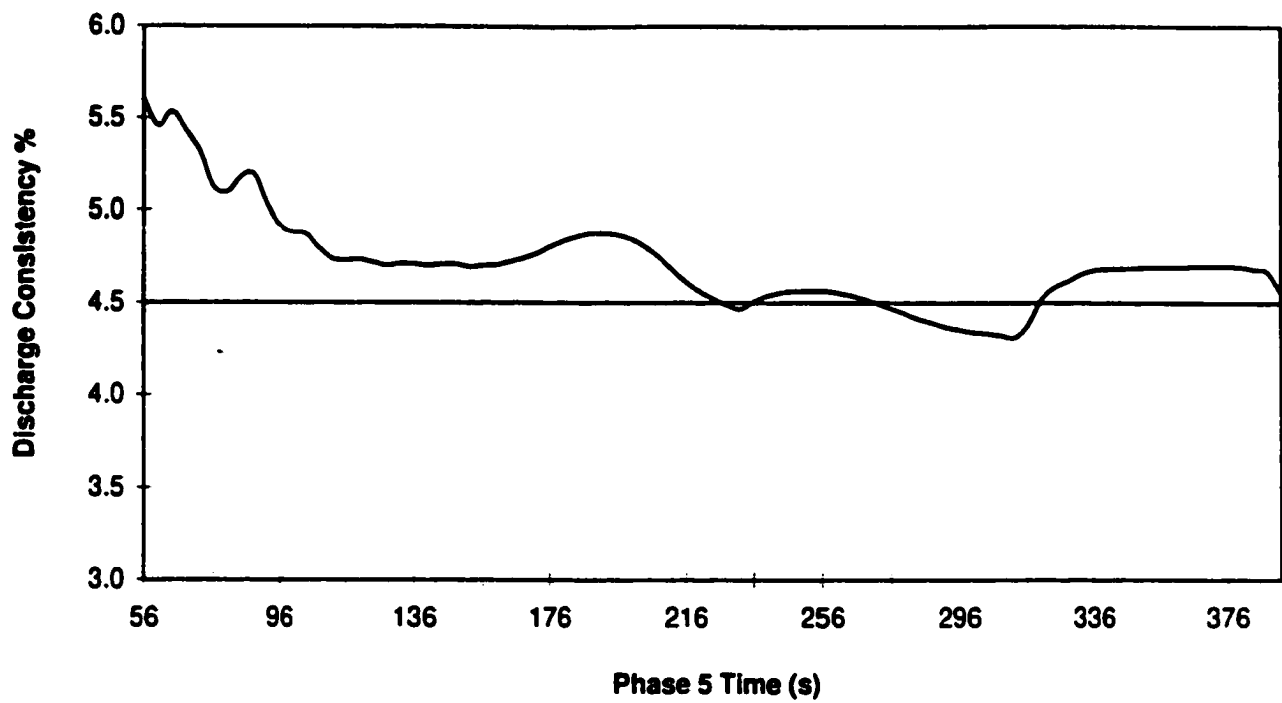

Figure 4.13 Calculated Phase 5 Pulper Discharge Consistency

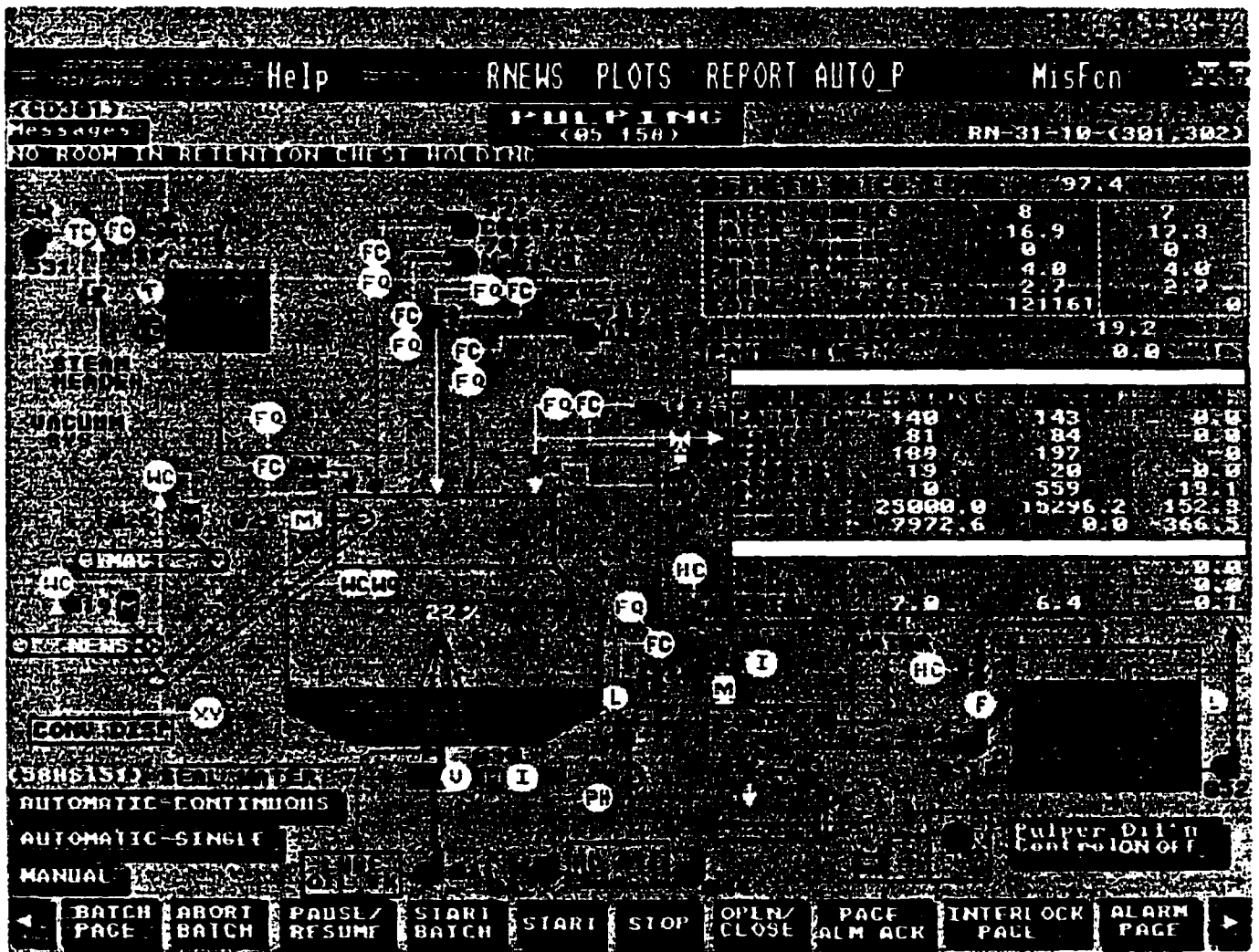

Figure 4.14 Operator Window Display Showing Pulper Discharge Consistency Control Toggle Point

Chapter 5

Feed Forward Pulper Head Tank Inventory Control

5.0 Introduction

Grey water is used as dilution water for consistency control and screening throughout the recycle process. During normal production, grey water used for dilution control returns to the grey water chest for re-use during stock thickening at the disc filter and twin wire press stages. Stock thickened to 30% consistency undergoes dispersion before further processing downstream. Subsequent dilution water demand is supplied by paper machine white water, and consequently does not normally impact on grey water inventory. During normal production, 500 L/min of grey water is lost in the pulp exiting the plant, while 2000 L/min is lost for contaminant removal. A constant purge of grey water is necessary to prevent the buildup of contaminants and metal ions in the system. The grey water loss is made up by paper machine white water or fresh water addition to the grey water chest.

The need for a continuous supply of makeup water impacts on grey water quality and mill operation [32]. Changing concentrations of calcium, magnesium, salts and other dissolved solids effect ink removal efficiency and fibre losses during flotation. The low pH of mill makeup water (pH 5) compared to the grey water pH of 9.0 can result in significant pH fluctuations in the grey water tank supplying the mill. The solubility of silicates present in the mill water, added to prevent hydrogen peroxide decomposition, is sensitive to mill pH. Below a pH of 9.0, silicates precipitate out of solution, resulting in hydrogen peroxide degradation and brightness problems due to alkaline darkening. Colloidal particles (also sensitive to pH) present in makeup water can interact with stickies and other particles present in waste paper, depositing on fibres and causing sudden degradation in pulp brightness. Thus the sudden change in grey water composition or pH caused by sudden changes in makeup water addition can result in unsatisfactory product before process adjustments can be made.

In order to minimize upsets associated with sudden changes in makeup water composition, it is important to control the addition of makeup water. Any change in the grey water inventory recirculated through the plant will change the concentration of contaminants present in the grey water, thereby acting as a perturbation on mill water chemistry. This can occur even during periods of constant makeup water composition. When the makeup water composition is highly variable, cyclic changes in the addition of makeup water to the process can result in sudden concentration changes in grey water composition in the grey water chest. The effect of variable makeup water flowrate increases the time for makeup water to mix with the grey water present in the system. The periodic addition of water of different composition from the mill grey water causes the grey water chest water composition to fluctuate with the changing makeup water flow, resulting in cyclic changes in the grey water composition throughout the plant.

Figure 5.0 shows the grey water chest control system. Grey water chest inventory supplies dilution water demand throughout the plant, acting as a holding tank for recirculating grey water recovered during pulp thickening. The grey water chest level is controlled by changing the makeup water flow line control valve position.

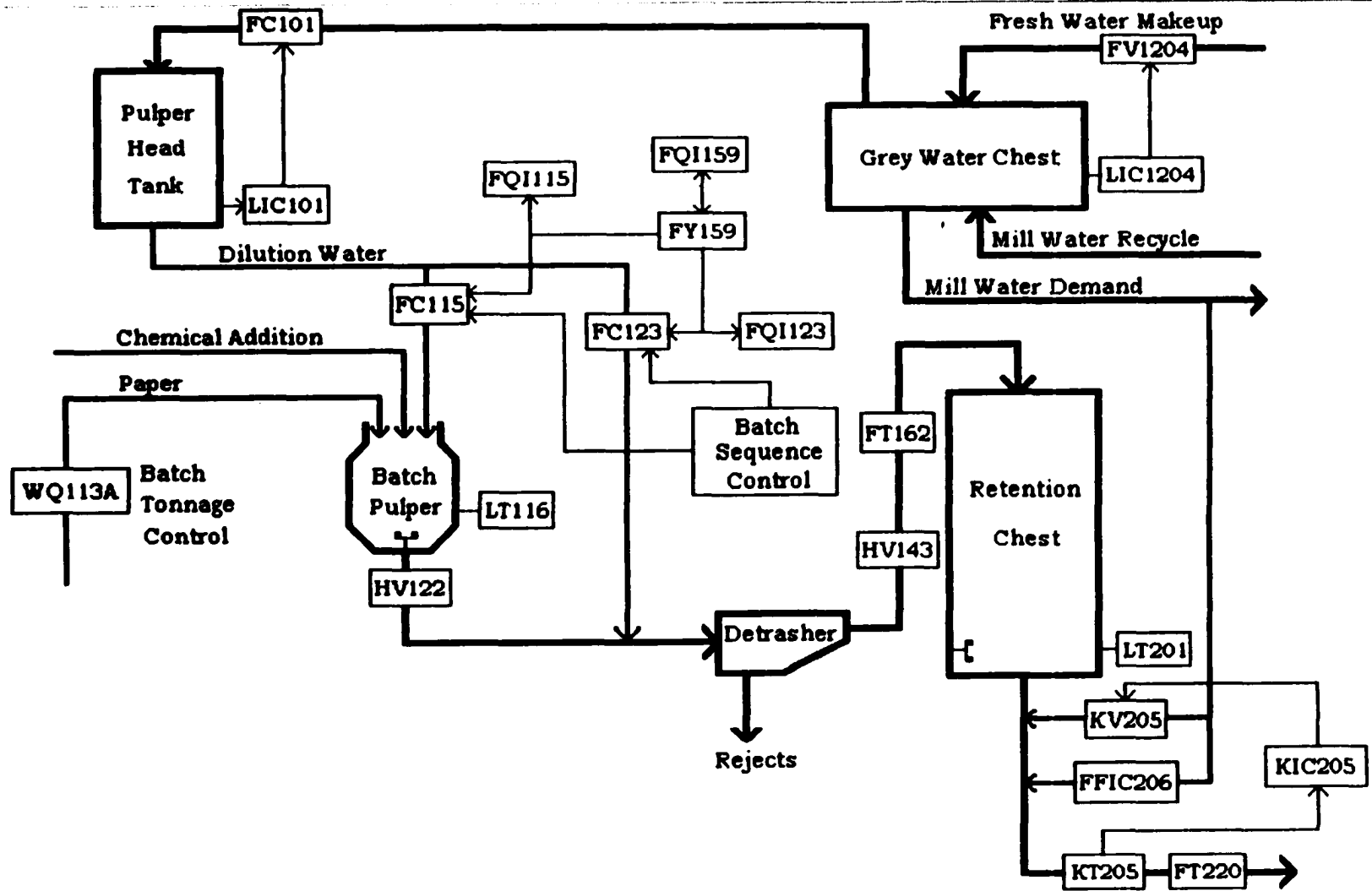

Figure 5.0 Grey Water Chest - Pulper Head Tank Control System

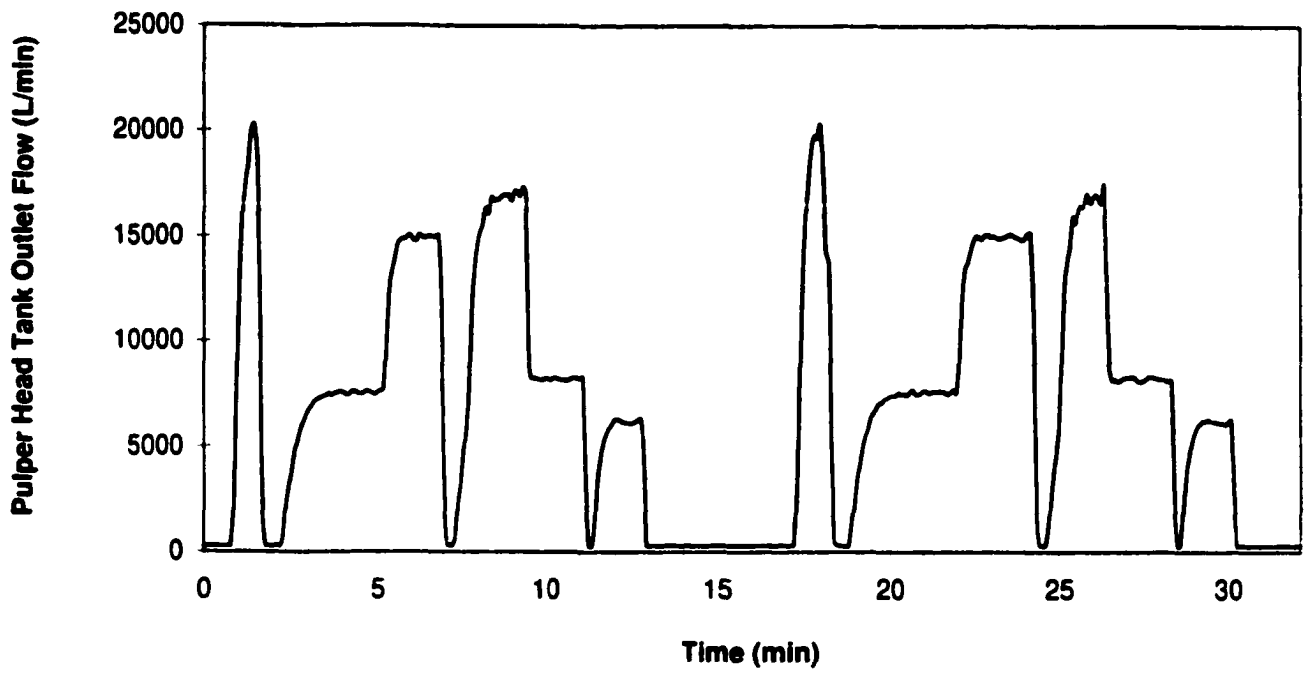

Figure 5.1 Batch Pulping Grey Water Demand Phase Variation

Control of grey water chest level is exacerbated by the cyclical nature of grey water demand for batch pulping. Figure 5.1 shows the grey water demand to the pulper during two batch pulping cycles. Typically a pulping batch requires approximately 140 000 litres of grey water, and lasts 22.0 minutes. However, as shown in Figure 5.1, the grey water demands varies considerably between phases. Phases 5 and 1, lasting approximately 12 minutes, typically use 110 000 litres of water for dilution, while phases 2, 3 and 4 require only 30 000 litres of water but last 10 minutes. This imbalance in dilution water demand throughout the pulping cycle impacts on grey water chest level control through the pulper head tank. As shown in Figure 5.2, the cyclic nature of grey water demand during pulping causes extreme level fluctuations in the pulper head tank. The high demand for dilution water in phases 5 and 1 produces a rapid drop in head tank level during phase 5, which subsequently recovers during phases 2 to 4. These rapid changes in head tank inventory produces a cyclical response in the PID controlled head tank feed flow FIC101, as seen in Figure 5.3. The rapid drop in head tank level during phase 5 causes the head tank feed flow to rapidly increase to the maximum flow. The controller maintains a high feed flowrate during phases 2 and 3, consequently enabling a rapid rise in head tank level and causing the controller to drop the feed flow to its minimum value to avoid exceeding the high level constraints. In the event of a batch pause after phase 3, or a reduction in the phase 2 dilution water demand caused by a drop in batch tonnage, the feed flow may be completely shut off by high level alarm constraints.

The rapid changes in pulper head tank feed flow required for level control consequently impact on grey water chest level, resulting in regular grey water chest level fluctuations as shown in Figure 5.4. The oscillations in grey water chest level are compensated by changing the makeup water flow to the chest, as shown by the makeup water flow valve position in Figure 5.5. The large changes in makeup water flow consequently impact on grey water chemistry.

The cause of varying makeup water flow is a consequence of both the changing pulper head tank demand and the grey water chest level control system. The major source of grey water chest level fluctuations occurs from the variation in grey water demand to the pulper head tank. The maintenance of a constant flowrate to the pulper head tank would therefore significantly reduce disturbances to grey water chest level control and enable a constant makeup water flow to the grey water chest. However, the rapid changes in makeup water demand are also a consequence of the tight response of the grey water chest level controller. The cyclical variations in pulper head tank demand cause oscillations in the grey water chest level by no more than 15% of full scale. Adjusting the tuning parameters of the PID controller to reduce the integral action and derivative control response would allow for greater grey water chest level fluctuation, but reduce unwanted disturbances to the makeup water flow. Increasing the span for high and low level constraints on the grey water chest would also reduce the controller imposed oscillation in the grey water makeup flow, allowing for a more gradual adjustment of grey water inventory.

Grey water chest PID settings are currently set at 60% proportional band, an integral time of 2.5 min and a derivative gain of 10.0. The low integral time is responsible for the sharp changes to makeup water flow, and should be increased to allow the normal oscillation from the pulper head tank flow. By adjusting the PID settings to allow proportional control of the grey

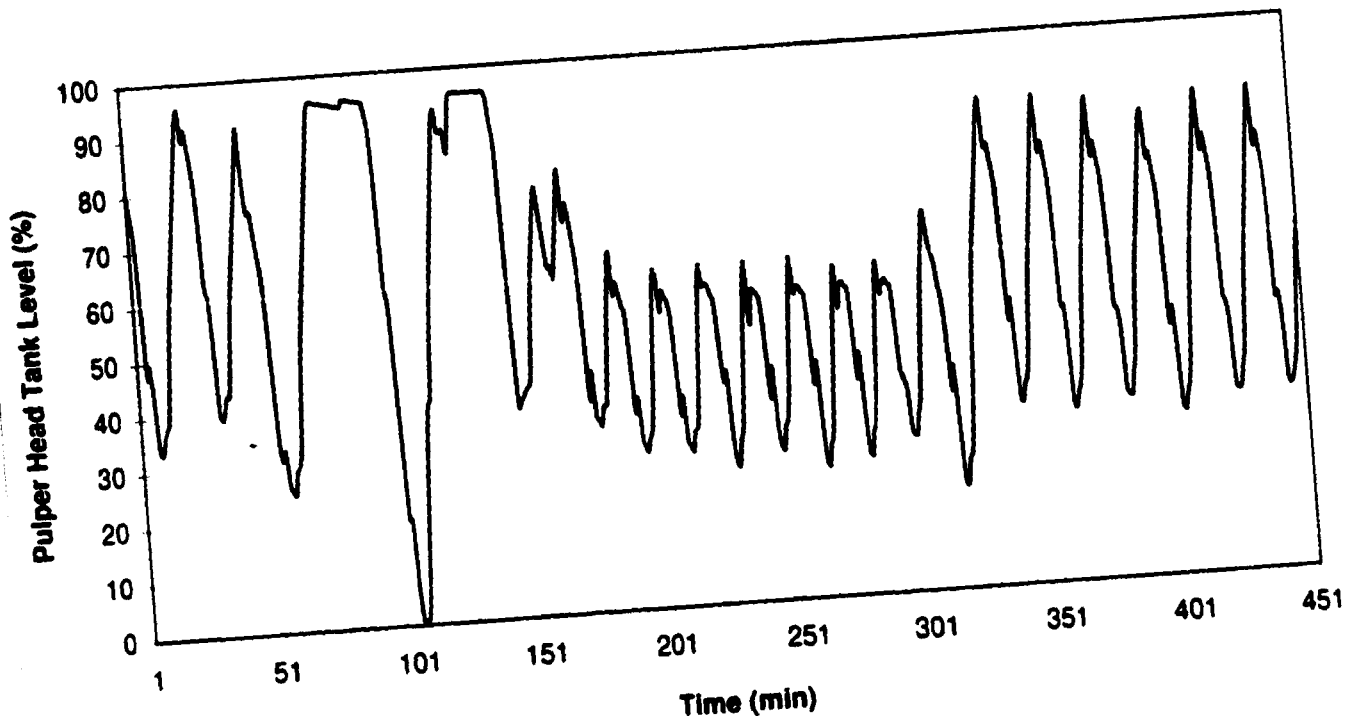

Figure 5.2 Long-Term Pulper Head Tank Level Variation During Plant Operation

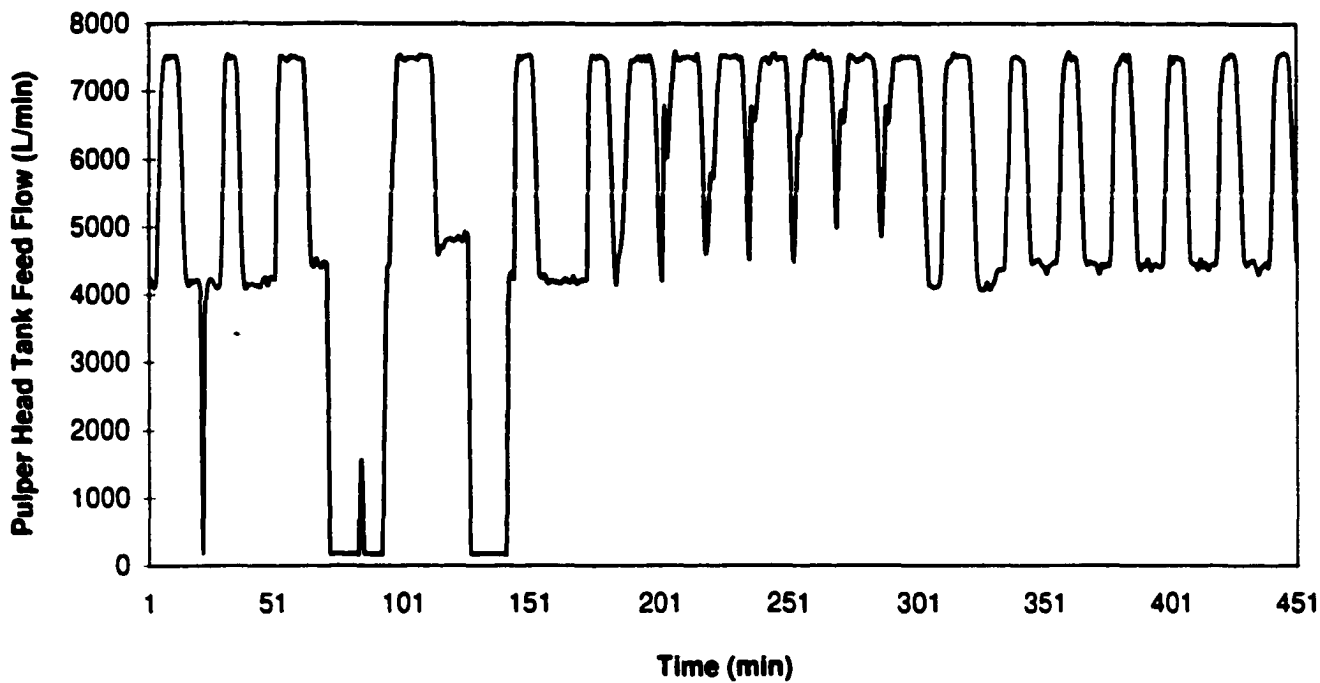

Figure 5.3 Long-Term Pulper Head Tank Feed Flow Variation During Plant Operation

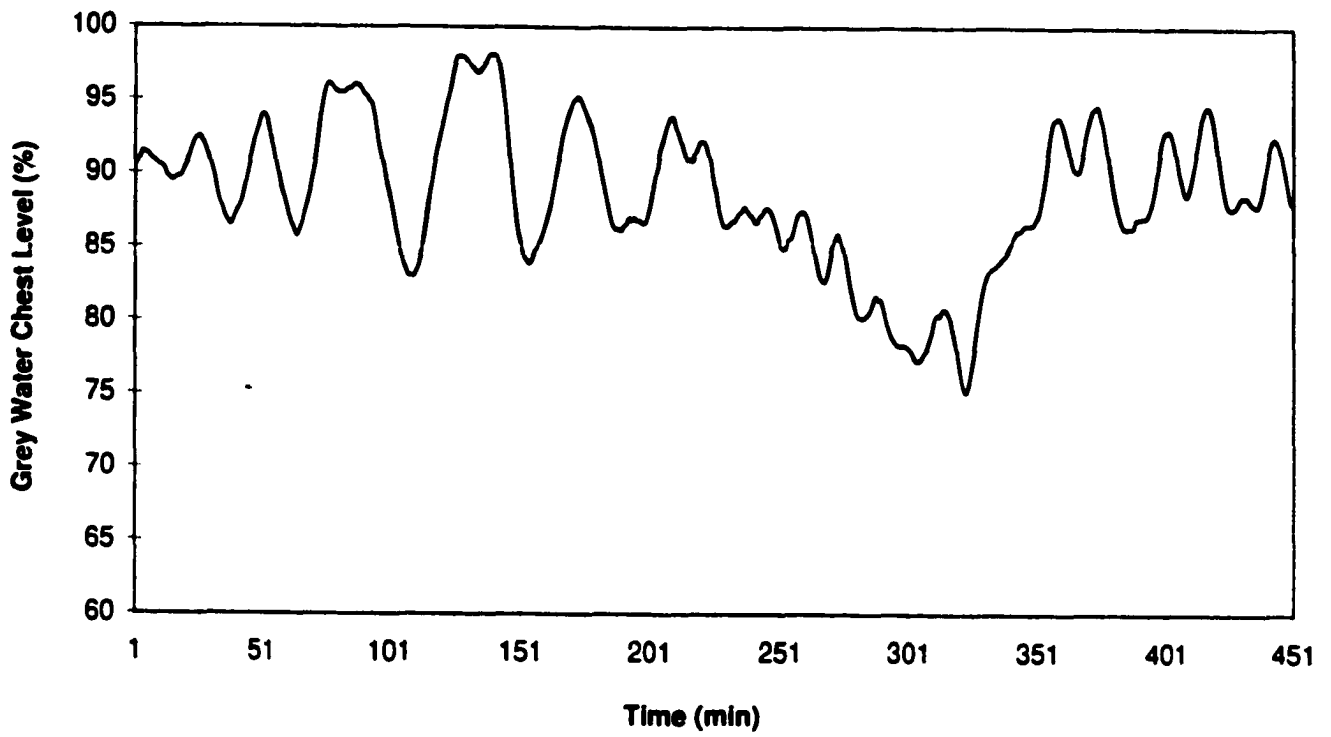

Figure 5.4 Long-Term Grey Water Chest Level Variation During Plant Operation

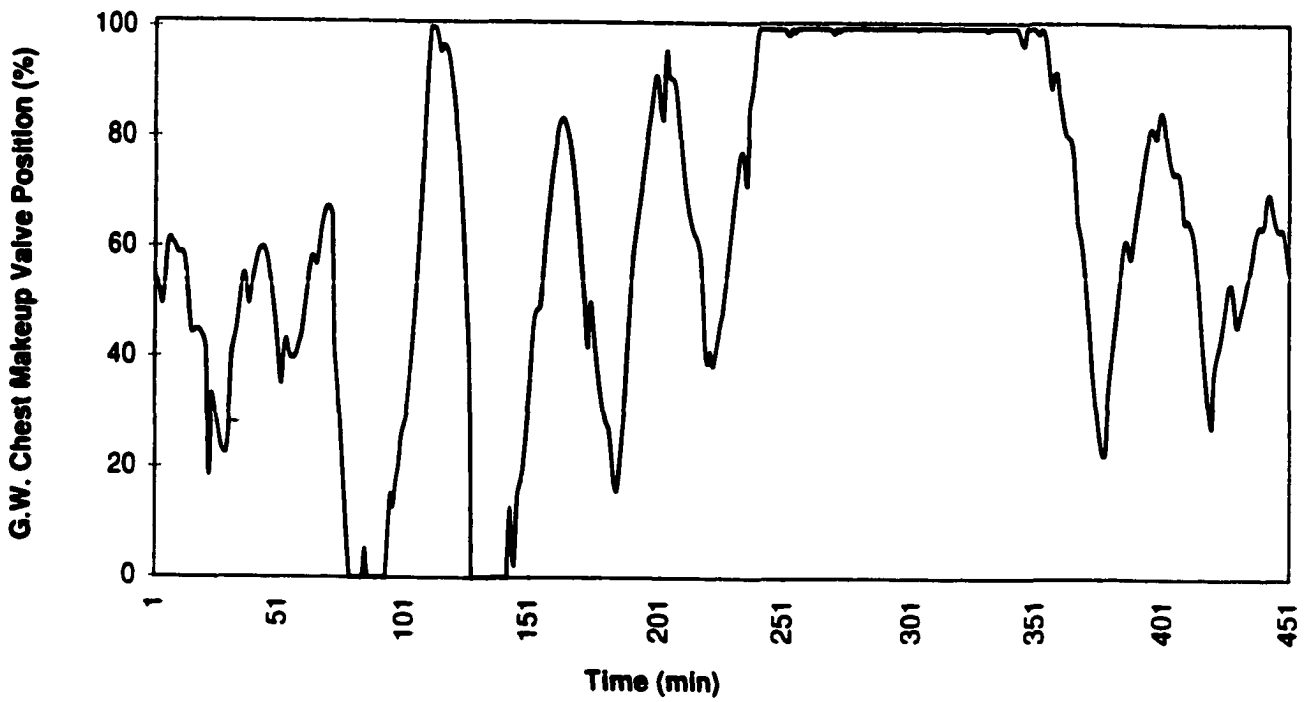

Figure 5.5 Long-Term Grey Water Chest Makeup Water Valve Position During Plant Operation

water chest level during normal tank level fluctuations, while setting the integral time to provide setpoint correction response, makeup water variation could be significantly reduced.

Avenor decided against making changes to grey water chest level control, primarily to protect the relatively small inventory reserve available in the chest. During normal production, the grey water chest supplies approximately 50 000 L/min dilution water demand from under 200 000 L of inventory. The relatively small tank size, coupled with a maximum grey water chest makeup flow of 10000 L/min, can only sustain grey water inventory for under 10 minutes. Therefore, tight control of the grey water chest level remained a priority.

A control strategy was therefore proposed to minimize the variation in pulper head tank feed flow while maintaining acceptable pulper head tank level control. The pulper head tank is undersized for the batch pulper. The maximum pulper capacity of 80000 L is inadequately sized to provide the phase 5 pulper demand of 85000-95000 L without addition from the grey water chest. For batch tonnages over 6.3 tons, the combination of head tank inventory and feed flow are inadequate to supply the dilution demand of 95000 L in phase 5 and 25000 L in phase 1, as shown in Figure 5.3 at 250 minutes. Consequently, head tank inflow must be increased during phase 1 to prevent the tank from emptying. However, the tank feed flow is now too high to prevent the head tank from over-flowing before the drawdown of dilution water begins again in phase 5. Thus the head tank inflow must be shut off again, repeating the cyclical oscillation in the feed flow.

Avenor attempted a material balance control procedure to regulate the head tank feed flow. Referring to Figure 5.0, a steady state water balance over the head tank, pulper and retention chest gives:

$$FC_{101} = FT_{220} * (1.0 - KT_{205}) \quad (5.1)$$

where KT_{205} is the consistency at flow transmitter FT_{220} .

With the head tank inflow in ratio to the plant production rate, the long term addition of dilution water compensates for the water lost from the retention chest.

This strategy failed to account for the actual production rate in the pulper, which sets the total batch grey water demand for the head tank. If the average pulper production rate, calculated as the batch tonnage/batch time, is less than the plant production rate, retention chest inventory will begin to fall. However, the lower pulper production rate will reduce the dilution water demand per batch, causing the pulper head tank to accumulate inventory while the plant production rate remains high. Because the retention chest can accommodate an imbalance between plant and pulper production rates for several hours, the head tank will eventually overflow if the head tank inflow remains ratioed to the plant production rate. Similarly, the pulper head tank will eventually empty if the pulper production remains greater than the plant production for extended periods of time.

To correct for this imbalance, the head tank feed flow was set according to the calculated

dilution water demand for the current batch tonnage and estimated batch time. The flow thus remains constant until tank level encounters a constraint violation. However, the absence of any feedback to monitor the tank level changes ensures that the tank level will not remain within the level constraints, eventually being controlled at one of the level constraint boundaries [33]. With this control, the natural oscillation of the pulper head tank level each batch (Figure 5.2) will eventually violate the high or low level constraints, causing a large and sudden change in the head tank inflow.

Also unaccounted for is the problem of batch pausing during the batch cycle. The batch pulper sequence execution is controlled by the retention chest inventory. Before beginning a new batch sequence, the batch controller determines if there is adequate room in the retention chest to hold a new batch. In the event of inadequate space, the batch pauses until the retention chest volume drops to allow addition of a new batch. The batch controller again determines if there is adequate room in the retention chest after phase 3, and remains paused in phase 3 until adequate space is available.

The controls on the head tank feed flow cannot compensate for these delays. Consequently, during an extended pause delay the head tank level will continue to increase, potentially resulting in a high level tank violation should the batch remain suspended for an extended period. The resultant drop in head tank feed flow again disturbs grey water chest level control and water quality. Figures 5.6 to 5.9 shows the head tank level controls and their impact on grey water chest control. The grey water chest level can be seen to oscillate in response to the changes in pulper head tank feed flow demand. It can be seen that the head pulper head tank level never drops below 50% throughout the phase, as a consequence of the high feed flow. However, because the tank level only falls to approximately 53% during phase 1, there is insufficient capacity left in the head tank to prevent it from overflowing before phase 5 if the present head tank feed flow is maintained. Thus the head tank rapidly reaches a level of 95%, at which point the feed flow is completely shut off. As Figures 5.7 and 5.9 show, changes in head tank feed flow directly impact on the flow of grey water chest makeup water.

Efforts to minimize changes in the head tank feed flow could be significantly improved by allowing greater fluctuation in the pulper head tank level throughout the batch. A lower feed flow to the head tank would enable the pulper head tank level to drop further during phase 5, enabling the maintenance of a constant head tank feed flow without overflowing the head tank before the next phase 5. With proper selection of the head tank feed flow, and allowing greater head tank level fluctuation throughout the batch while preventing level constraint violations, variations in the feed flow can be significantly reduced. The major limitation to maintaining a constant head tank inflow is the high grey water demand in phase 5.

With batch tonnages significantly above 6.3 tons, it is not possible to accumulate adequate head tank inventory to supply dilution water demand during phases 5 and 1 without significantly increasing pulper head tank feed flow. Depending on the batch time, the high feed flow in phase 5 cannot be maintained throughout the batch without overflowing the head tank at some point. Under such conditions, however, optimal selection of head tank feed flow would allow for further minimizing the variation in head tank feed flow while maintaining level control.

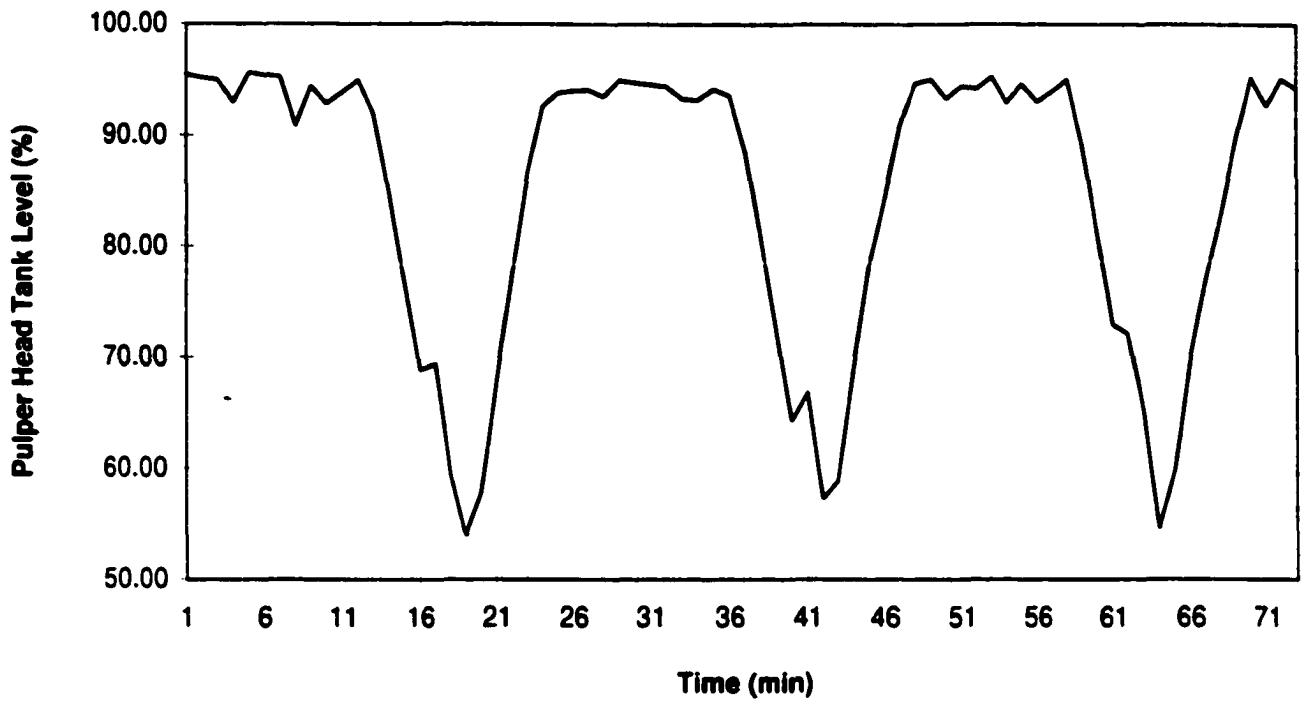

Figure 5.6 Pulper Head Tank Level Batch Variation

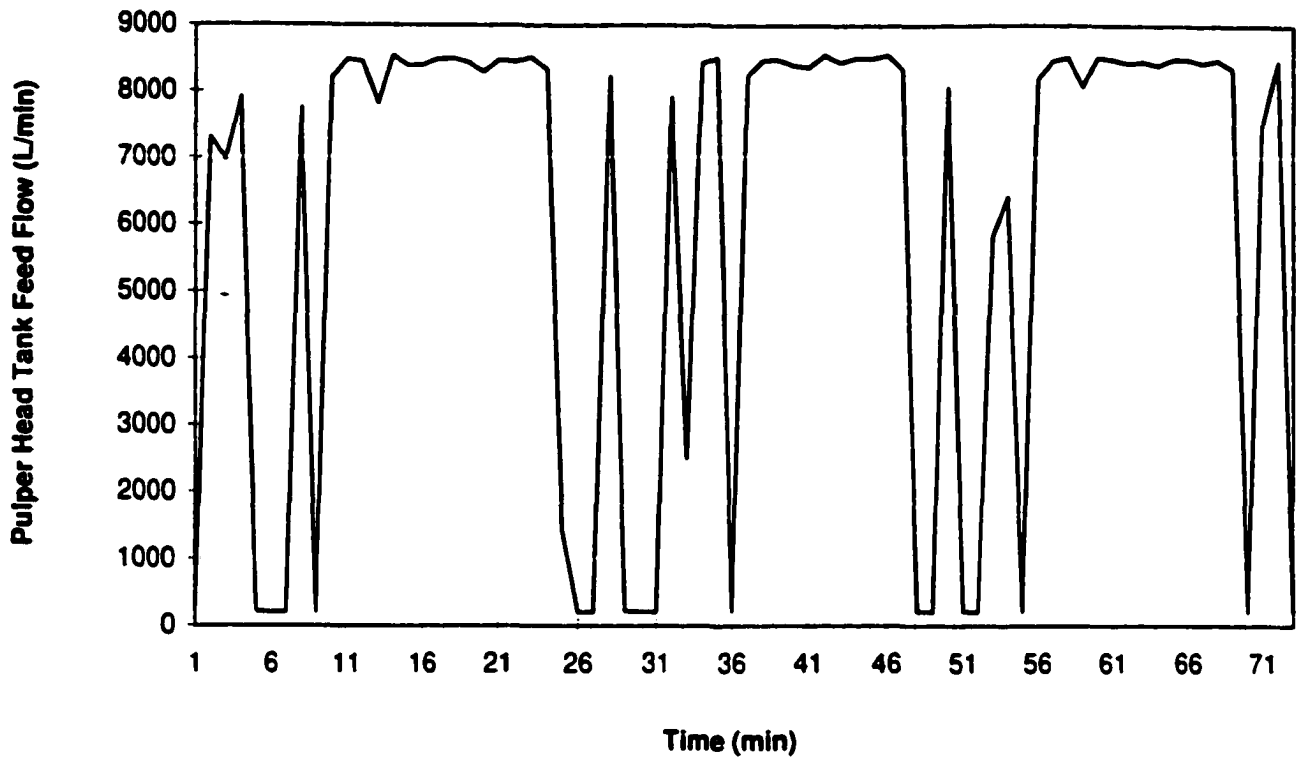

Figure 5.7 Pulper Head Tank Feed Flow Batch Variation

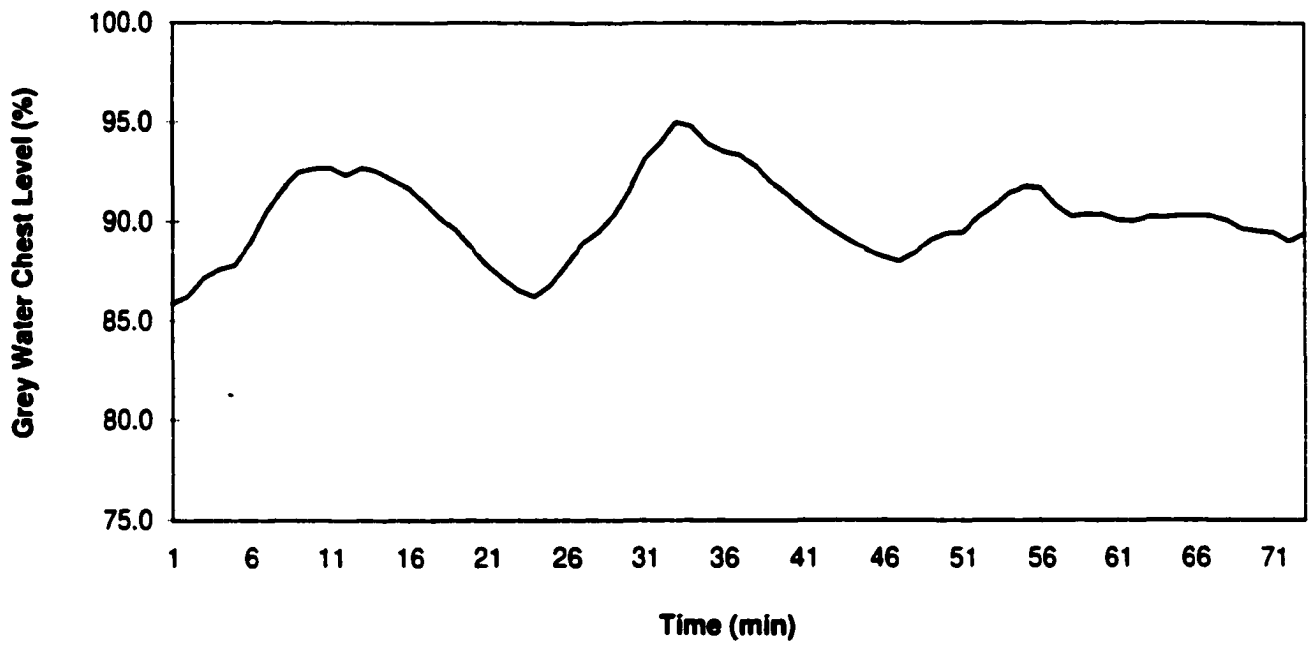

Figure 5.8 Grey Water Chest Level Batch to Batch Variation

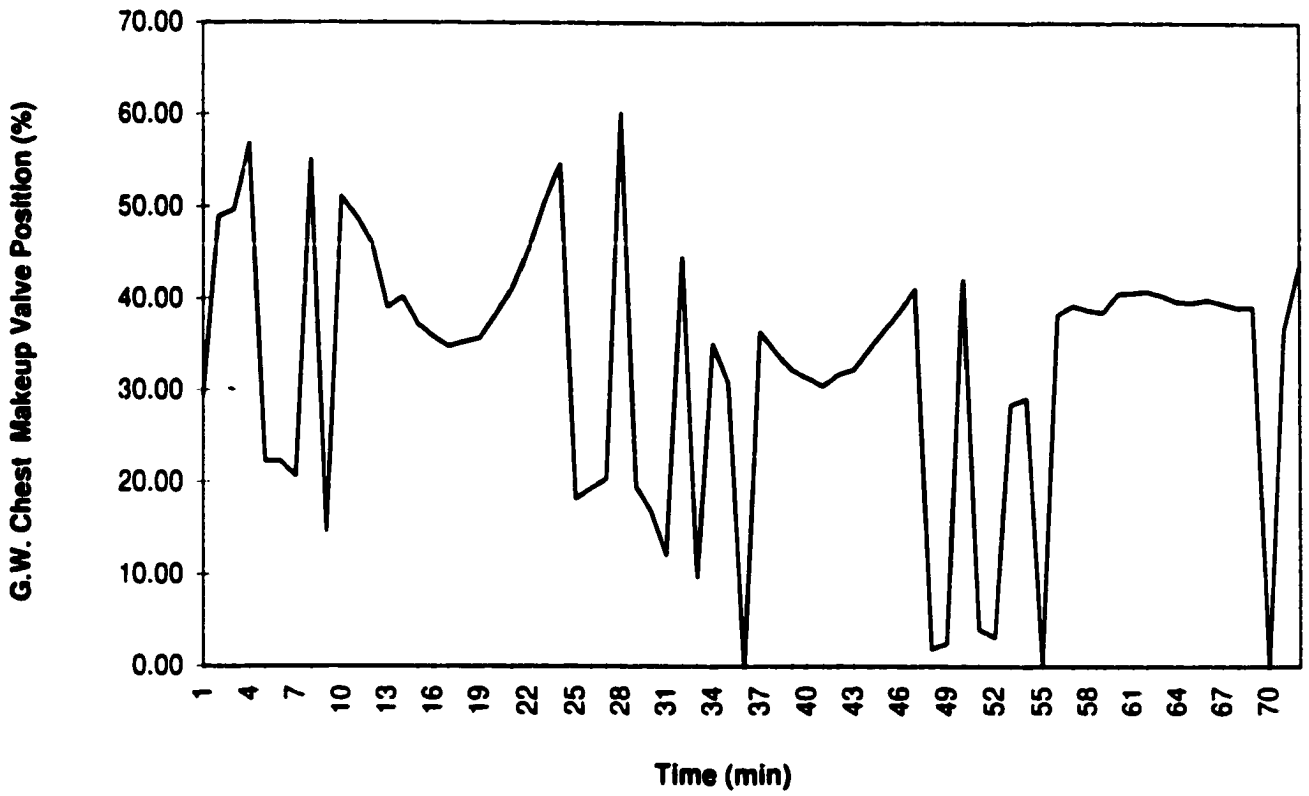

Figure 5.9 Grey Water Chest Makeup Water Valve Position Variation

Head tank feed flow variation can be minimized by better control of batch tonnage and head tank feed flow. The impact of pulping operations on pulper head tank inventory can be minimized by equalizing the pulper production rate to the retention chest production rate. During normal pulper operations, the batch pulping of 6300 kg in 20 minutes corresponds to pulper production rate of 454 tons/day. However, if the production rate out of the retention chest is 350 tons/day, the higher pulper production rate will cause stock accumulation in the retention chest. Once the retention chest is full, the continuation of a higher pulper production rate will cause between batch delays in pulping, until the retention chest level drops sufficiently to allow room for the next batch.

The extended pausing during pulping can last over 5 minutes, during which time the pulper head tank continues to accumulate inventory if the head tank flow is kept constant. If the head tank flow remains unchanged, the head tank will overflow before pulper dilution demand begins. Alternatively, the pause time could be used to calculate the total batch time and reduce the average head tank feed flow accordingly. However, during phase 5, the reduced flowrate will be insufficient to prevent the head tank from emptying, and will have to be increased. This effect of insufficient grey water supply for phase 5 is exacerbated as the batch tonnage is increased. The higher batch tonnage increases the demand on the head tank during phase 5, requiring a change in head tank feed flow to supply the demand. However, the prolonged batch pausing, required to prevent over supplying the retention chest, necessitates a decrease in the head tank flow after phase 5 to prevent the head tank from overflowing. Therefore a persistent fluctuation in head tank feed flow is required to maintain pulper head tank level control.

There is, however, no need for a greater pulper production rate than the retention chest can handle. The unnecessarily high batch tonnage causes a further imbalance in the distribution of grey water demand throughout the batch cycle, exacerbating level control problems in the pulper head tank. By setting the pulper production rate equal to the retention chest production rate, both the phase 5 dilution water demand and the need for batch pausing can be minimized.

To set the batch tonnage, automated as a CALC block, would correct this problem as outlined in the 4 steps below:

1. Calculate the retention chest capacity and current production rate. If the retention chest capacity falls below a low inventory level of 40%, set the pulper production rate greater than the current plant production rate to provide for stock accumulation in the retention chest at a controlled rate of 10% of retention volume per batch. If the calculated batch tonnage is greater than the maximum batch tonnage, set it equal to the batch tonnage limit.
2. Calculate the remaining retention chest capacity for new stock, and the volume of stock produced from the current pulper batch. If the remaining retention chest capacity is greater than 120% of the upcoming batch volume, continue with the current batch tonnage setpoint. If the remaining capacity in the retention chest is less than 120% of the current batch volume, set the next batch tonnage to provide a pulper production rate equal to the current average plant

production rate.

3. Maintain the current batch tonnage until the average plant production rate changes by more than 20%, or a setpoint change to plant production rate is made. This will avoid unnecessary changes in batch tonnage, which could exacerbate head tank level control by changing the pulper grey water dilution demand each batch.
4. Repeat steps 1-3 at the start of each batch.

To improve head tank inventory control, a strategy was developed to minimize the variance in the pulper head tank feed flow while preventing level constraint violations. To avoid the problem of unnecessary pulper head tank flow changes associated with using the pulper head tank level for feedback, the conventional PI feedback control was replaced with a feed forward control strategy. The feed forward controller employs the available information from the batch pulper to anticipate changes in the grey water dilution demand, thereby minimizing the need for drastic and sudden changes to the pulper head tank feed flow, which impact on grey water chest control.

The control algorithm was tested by simulating the operation of the batch pulper and pulper head tank. The control algorithm is shown in Appendix C, and discussed below. The on-line availability of batch grey water phase demands and phase times enables prediction of the head tank level from the current pulper head tank feed flow. Should the predicted head tank level remain within the level constraints, the head tank feed flow can be kept constant. By calculating the head tank level changes throughout the upcoming batch, adjustments can be made to the head tank feed flow to ensure that level constraints are not violated. However, the prediction of level constraint violations before they occur enables selection of the minimum change in head tank feed flow necessary for level control. This feed-forward strategy avoids the unnecessary reliance of PID or deadband controls on feedback, and enables use of available batch information to make compensations before excessive changes to head tank feed flow are required.

5.1 Pulper Head Tank Feed Forward Level Control Algorithm

The pulper head tank feed forward level control algorithm operates once per Batch phase to calculate the minimum pulper head tank feed flow change necessary to keep the Head tank level within the prescribed constraints. The head tank feed flow remains unaltered if the current feed rate will maintain level control.

1. Initialize the controller at the start of phase 1. Determine the Batch tonnage, phase water demands, predicted phase times, and current pulper head tank level. Set the initial head tank feed flow (FIC101) to FIC_MEAN, the average pulper head tank feed flow for the

last batch sequence.

2. Initialize the controller at the start of phase 1. Determine the batch tonnage, phase water demands, predicted phase times, and current pulper head tank level.
3.
 - a) At the start of the current phase, update the pulper head tank level, phase water demands, and current FIC101 flowrate.
 - b) Calculate the pulper head tank level expected at the start of phase 5 discharge from the current head tank feed flow, level and expected phase times. If, at the current value of FIC101, the head tank level will exceed its upper level constraint before the start of phase 5, calculate the minimum change in FIC101 necessary to prevent head tank overflow. Set FIC101 to avoid the high level constraint. Stop calculations for current phase. Goto step 4.
 - c) If the current FIC101 flow will not cause a high level violation before phase 5, calculate the head tank level at the start of phase 5. From the calculated head tank level at the start of phase 5 (or current measured head tank level during phase 5), project the head tank inventory at the end of phase 5 from the current FIC101 flow, phase 5 water demand and expected phase 5 discharge time.
 - i) If, at the current FIC101 flow, the head tank will violate the pulper head tank low level constraint by the end of phase 5, calculate the minimum increase in FIC101 flow necessary to ensure adequate phase 5 head tank feed flow to prevent a low level violation in phase 5. Return to step 3a.
 - ii) If, at the current FIC101 flow, the head tank level will remain within constraints for the rest of the batch, maintain current FIC101 flow and proceed to step 4.
4.
 - a) Calculate the current phase time and store.
 - i) If the phase time did not exceed the phase limit alarm time, assume the Phase execution performed without operating problems.
 - ii) If the Phase limit time alarm is exceeded, set the phase time to the phase limit alarm time.
5. Goto Step 3 at the start of the next phase period. If the next phase is 1, Goto step 2.

5.2 Results and Discussion

To demonstrate the potential of feed forward control to reduce the variation in pulper

head tank feed flow, simulations of the batch pulping sequence were performed with varying batch tonnages, unexpected delays between batches, and with flow controller offset error between the flow controller setpoint and actual feed flow. The batch pulping process was simulated with Matlab sequence code, and is shown in Appendix C. The code simulates the phase timing, phase water demand flowrates and water volumes drawn off the head tank to the pulper during batch execution.

Figures 5.10-5.12 shows the behaviour of the head tank level and feed flow with feed forward control and batch to batch tonnage variation. Figure 5.10 shows the batch tonnage, which varies between 5.8 and 6.9 tons. Figure 5.10 also shows the phase time and duration throughout the simulation. Figure 5.11 shows the pulper head tank level throughout the simulation. To demonstrate the control response to a high tank level, the simulation begins in phase 1 with the head tank at a high level of 63.0%. At this level, high for phase 1, the pulper head tank will overflow before phase 5 at the current head tank feed flow and batch tonnage. Figure 5.12 shows the head tank flow change correction to prevent head tank overflow before phase 5. After correction for the high initial head tank level, the head tank feed flow returns to a stable feed flow between 6600-6300 L/min for the duration of the simulation. Figure 5.11 shows that the head tank level reaches the high level limit of 95% at the start of phase 5, and remains controlled for the duration of the simulation. The feed forward controller low level limit is set at 20% at the end of phase 5 to guard against emptying the head tank. It was observed at Avenor, and verified in the simulations, that the head tank level never drops more than 10% from the level at the end of phase 5. Therefore, the controller limits the head tank level to 20% at the end of phase 5, which at worst will allow the head tank level to drop to 10% sometime in phase 1. However, the low tank level in phase 1 is not a concern because the demand on the head tank will not begin drawing down head tank inventory until phase 5, when the head tank level will have returned to above 60%.

Figures 5.13-5.19 shows the control response to a sudden change in the between batch pause time, caused by operating problems requiring temporary shut-down, delays from phase 5 discharge plugging, or by high retention chest inventory which prevents a subsequent pulping batch from beginning until there is sufficient room in the retention chest. Figure 5.13 shows the between batch delay times and phase periods for the simulation. The between batch delay time is initially set at 0.3 min, before encountering a pause delay of 2.4 minutes duration 163 minutes into the simulation. Figures 5.14 and 5.15 show the head tank level and feed flow throughout the simulation. As in the previous simulation, the head tank initial level in phase 1 is set at a high value which requires flow compensation to prevent overflow before phase 5.

As Figure 5.15 shows, the head tank flow drops to 5900 L/min in response to the pause delay at 163 minutes, thereby protecting against the high head tank level constraint. Upon return to normal pulping operation without delays at 278 minutes, the head tank flow returns to its previous value for the duration of the simulation.

Figures 5.16 and 5.17 show the head tank level control and flow response with a +5%

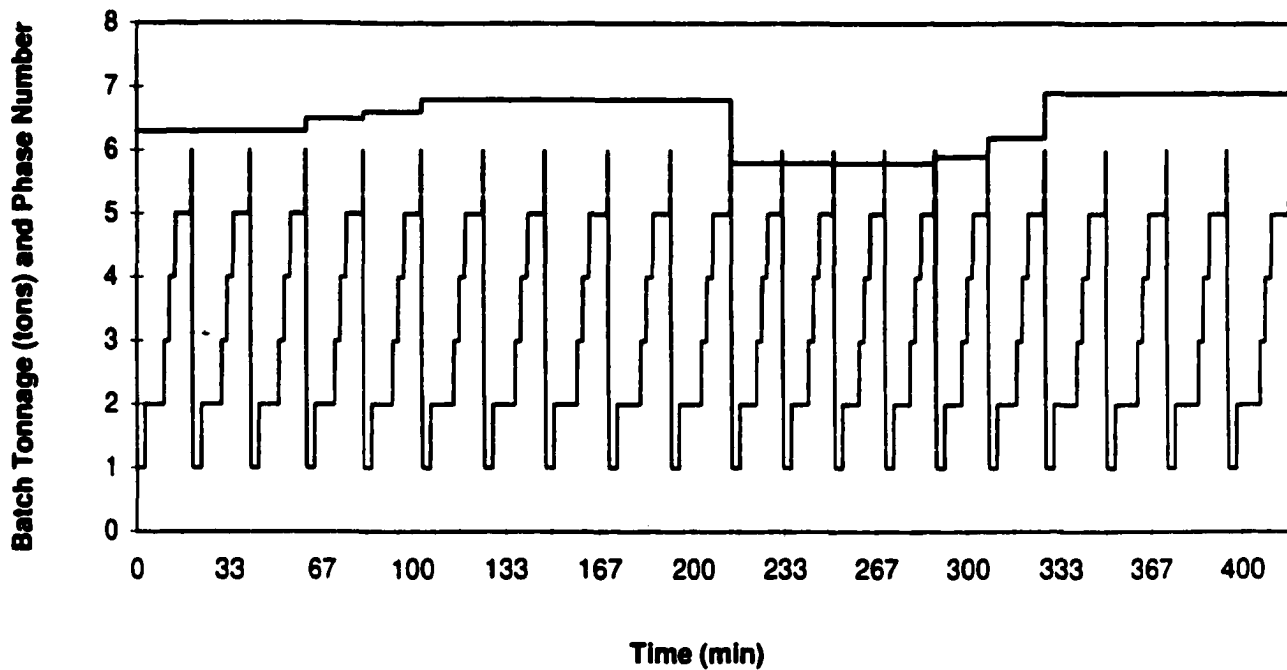

Figure 5.10 Batch to Batch Tonnage Variation and Phase Times for Figures 5.11 and 5.12
Initial Batch Tonnage = 6.4 tons; Initial Phase Number = 1.0

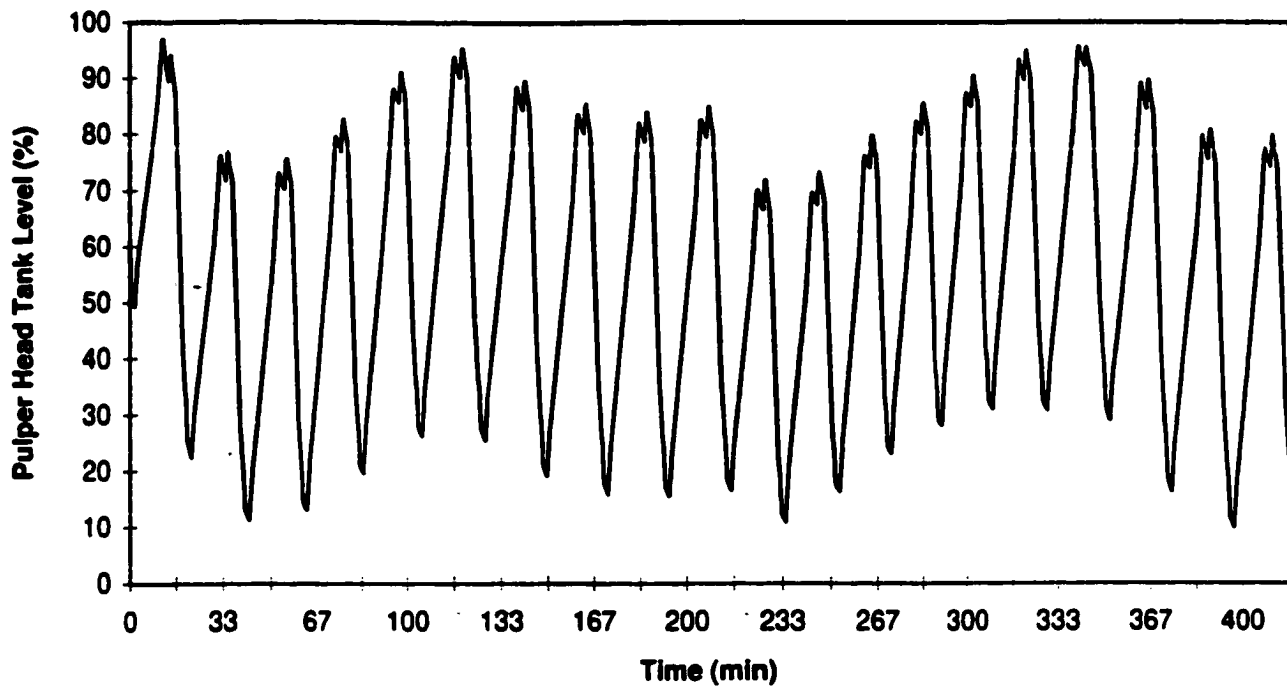

Figure 5.11 Simulated Pulper Head Tank Feed Forward Level Control With Batch to Batch Tonnage Variations From Figure 5.10

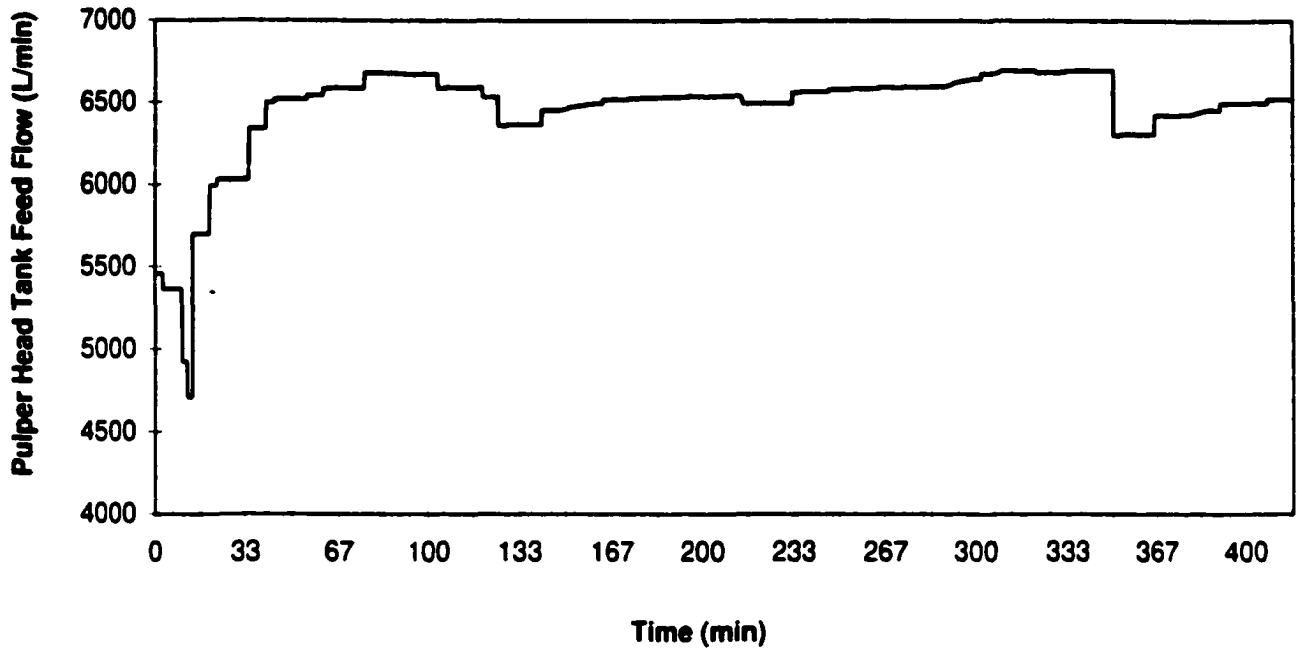

Figure 5.12 Simulated Pulper Head Tank Feed Flow Under Feed Forward Control With Batch to Batch Tonnage Variations From Figure 5.10

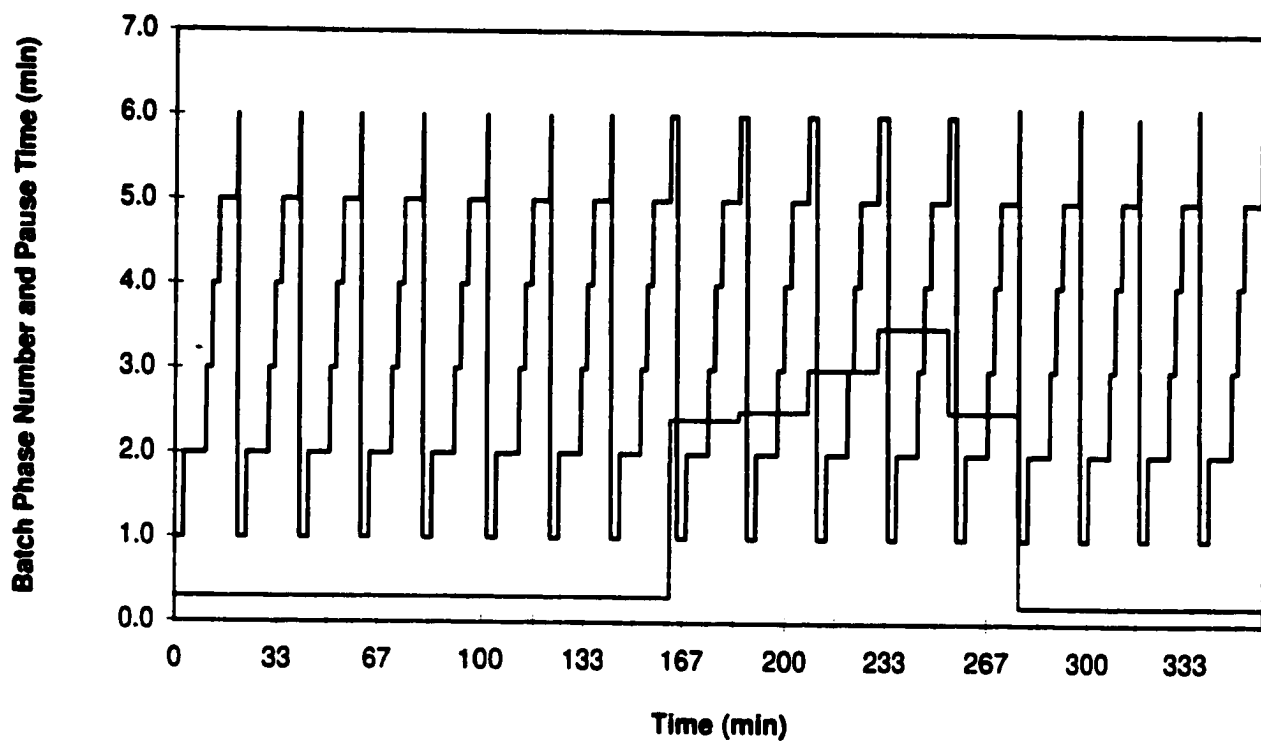

Figure 5.13 Between Batch Pause Times and Phase Times for Figures 5.14, 5.15, 5.16, 5.17, 5.18, and 5.19
Initial Batch Tonnage = 6.4 tons; Initial Pause Time = 0.3 min
Initial Phase Number = 1.0

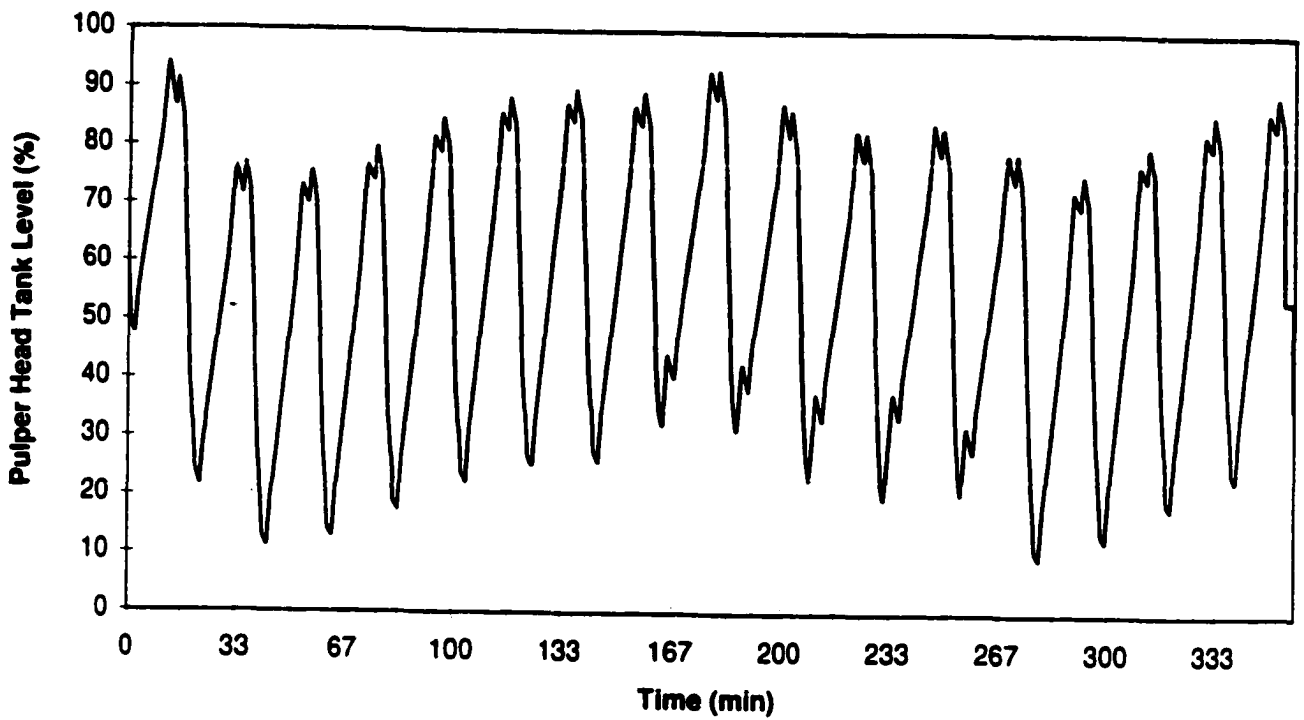

Figure 5.14 Simulated Pulper Head Tank Feed Forward Level Control With Between Batch Pause Delays

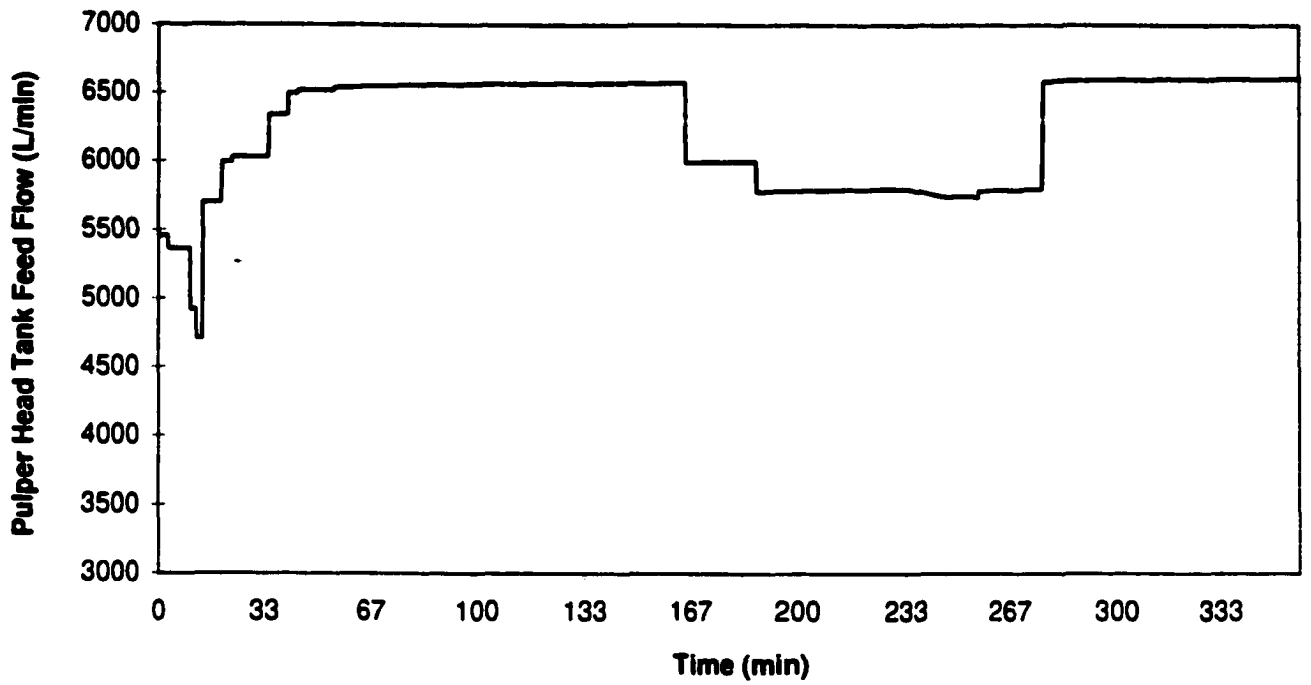

Figure 5.15 Simulated Pulper Head Tank Feed Flow Under Feed Forward Control With Between Batch Pause Delays

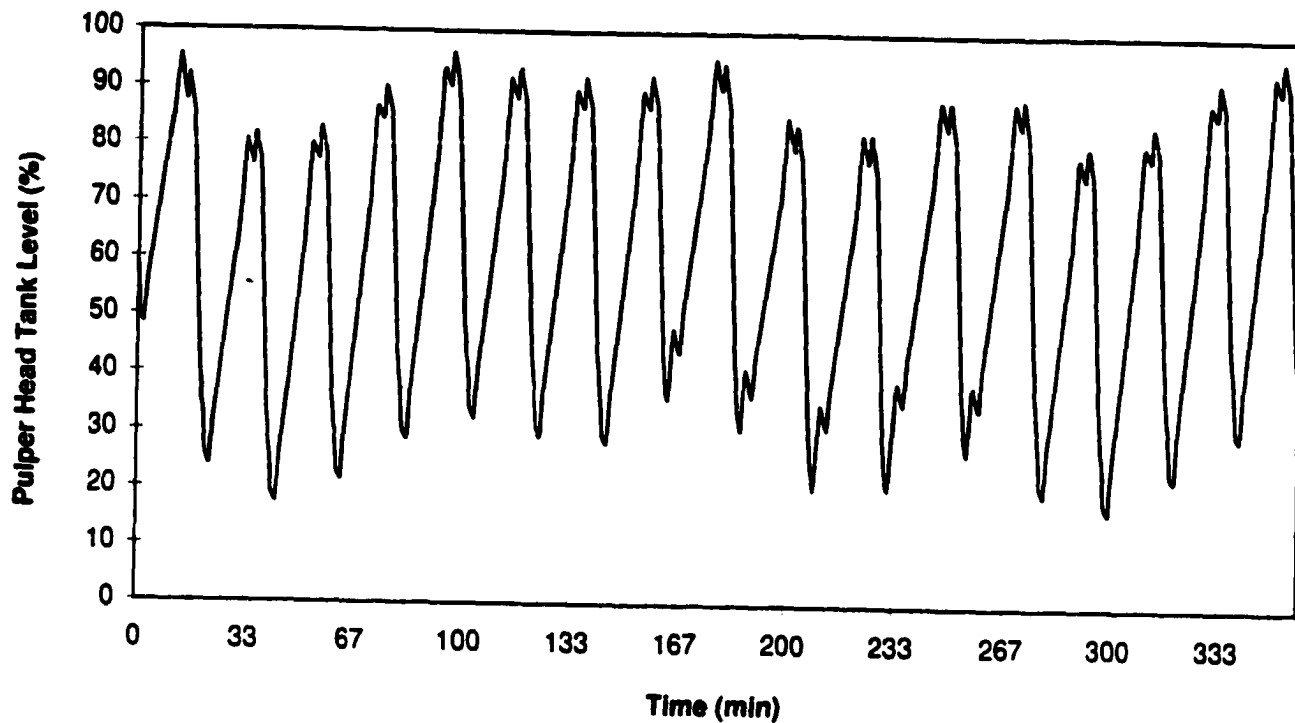

Figure 5.16 Simulated Pulper Head Tank Feed Forward Level Control With Between Batch Pause Delays and Under Conditions with a +5% Offset Between the Pulper Head Tank Setpoint Feed Flow and Actual Feed Flow

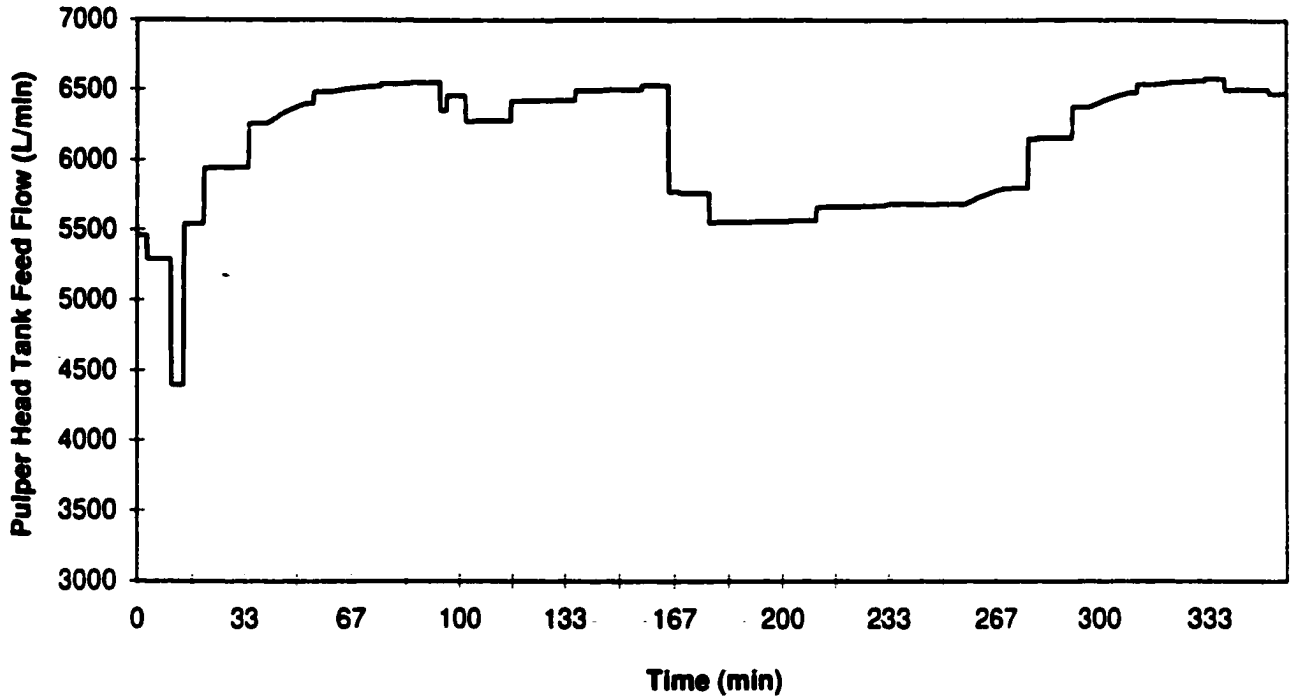

Figure 5.17 Simulated Pulper Head Tank Feed Flow Control With Between Batch Pause Delays and Under Conditions with a +5% Offset Between the Pulper Head Tank Setpoint Feed Flow and Actual Feed Flow

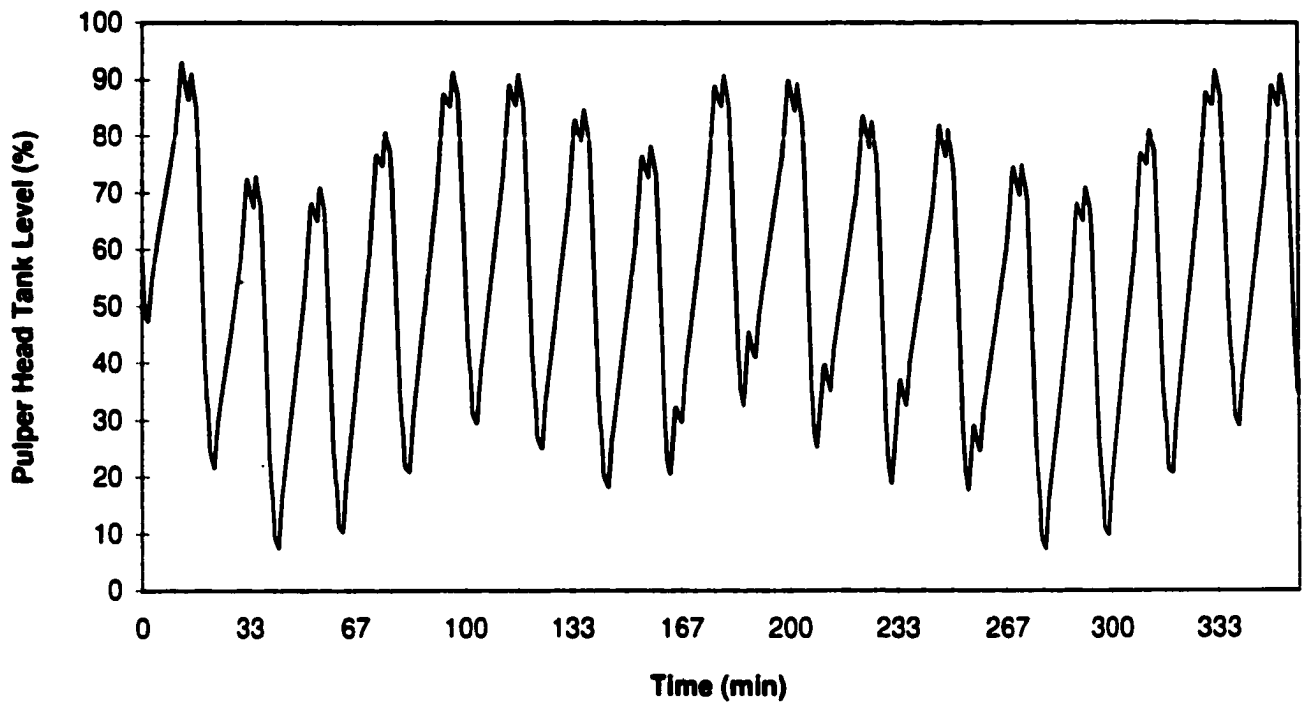

Figure 5.18 Simulated Pulper Head Tank Feed Forward Level Control With Between Batch Pause Delays and Under Conditions with a -5% Offset Between the Pulper Head Tank Setpoint Feed Flow and Actual Feed Flow

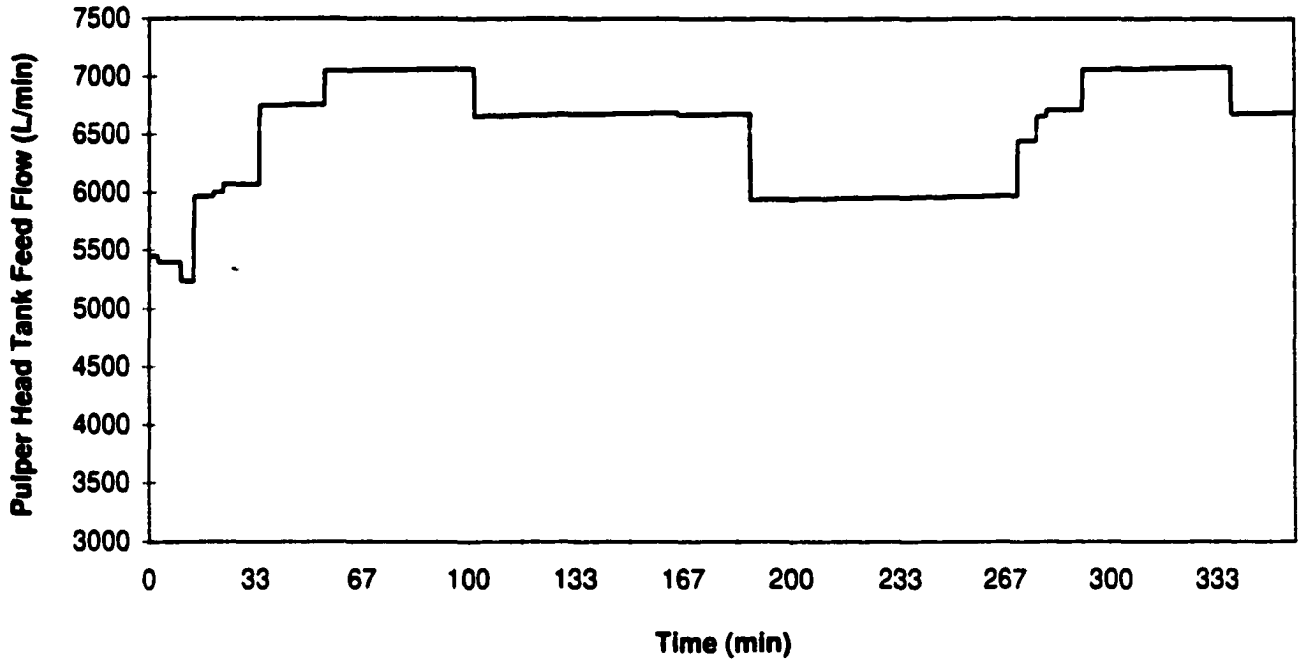

Figure 5.19 Simulated Pulper Head Tank Feed Flow Control With Between Batch Pause Delays and Under Conditions with a -5% Offset Between the Pulper Head Tank Setpoint Feed Flow and Actual Feed Flow

offset error between the head tank feed flow setpoint and the actual FIC101 flow obtained. The effect of the instrument offset or miscalibration causes an oversupply of dilution water to the head tank, as shown in Figure 5.16. The oversupply of dilution water causes the average head tank level to increase, and increases the variation in FIC101 to compensate accordingly. However, because flow compensation occurs at the start of each phase, the offset between the predicted level from the current head tank feed flow setpoint and the actual level change enables the feed forward controller to make compensation at the start of each phase by reducing the FIC101 flow setpoint if necessary.

Figures 5.18 and 5.19 shows the corresponding level control and FIC101 flow response with a -5% flow offset in flow controller FIC101, consequently causing undersupply of head tank feed water. The under supply of water reduces the concern with high level tank violations, and thereby minimizes the flow response and level fluctuation associated with the batch pause delays at 163 minutes. However, the undersupply of dilution water causes the head tank level to drop to a low level of 9% at 278 minutes in response to the sudden removal of the batch pause delay. The feed forward controller compensates for the low head tank level by increasing the FIC101 setpoint to 7100 L/min after the pause delay period before stabilizing at 6700 L/min, as compared to a flow setpoint of 6500 L/min for the feed forward controller without FIC101 flow offset.

Figures 5.20-5.24 compares the performance of the feed forward controller with the conventional level control system at Avenor using on line process data from mill operation. Figure 5.20 shows the batch tonnage, between batch pause time and phase times during a 4 hour period of mill operation.

The between batch pausing and excess level control response causes the pulper head tank level to reach its high level limit, shutting off the head tank feed flow every batch. As shown in Figure 5.22, the rapid initial drop at the start of the next batch causes the controller to respond with the maximum flow available, causing the head tank level to remain high (Figure 5.21). By allowing greater head tank level variation while controlling within the high and low level constraints, the pulper head tank feed flow variation can be significantly reduced. Figure 5.23 shows the pulper head tank level under feed forward control. The head tank level is permitted to vary within the level constraint boundaries, allowing for a steady flowrate with minimum variation as shown in Figure 5.24.

Table 5.0 summarizes the performance of the feed forward head tank level controls with reference to the variation in pulper head tank feed flow. Measurement offset error in the FIC101 flowmeter increases the flow variation by between 5-15%. Comparing the feed forward control performance with the conventional controls at Avenor shows a significant reduction in head tank feed flow standard deviation from 3203 to 338, corresponding to a decrease in the head tank feed flow variance by over 95%. By protecting against the need for drastic reductions in head tank feed flow associated with oversupplying the pulper head tank during phases 1-4, significant improvement in minimizing the impact of pulper head tank operation on grey water chest level control and makeup water flow can be achieved.

It is difficult to assess the impact of improved pulper head tank level control on overall mill water chemistry and brightness control. The feed forward pulper head tank level control

system has been in operation at Avenor (Avenor Inc. became Bowater Inc. on August 22, 1998) from August 15, 1998. Any reduction in the frequency of mill grey water chemistry upsets would be anticipated to reduce the variation in mill brightness. Flotation inlet brightness measurements sampled at two hour intervals were collected from May 18, 1998 to September 30, 1998 and examined to assess the effect of the feed forward pulper head tank level controls after August 15, 1998. Comparison of the brightness variation from May 18 to August 14 and from August 15 to September 30 showed a reduction in flotation inlet brightness variance from 5.8 to 3.4 ISO². An F-test comparing the variances of the two sets of data can be used to test the null hypothesis $H_0: \sigma_1^2 = \sigma_2^2$ versus the alternative hypothesis $H_a: \sigma_1^2 \neq \sigma_2^2$, where σ_1^2 and σ_2^2 are respectively the flotation inlet brightness variance before and after implementation of the pulper head level controls [34]. If $F > F_{0.05}(v_1, v_2)$, where $F = s_1^2/s_2^2$ is the ratio of the variances of the brightness data sets from May 18 to August 14 and from August 15 to September 30, then the null hypothesis can be rejected at the 5% significance level. With $F = 5.8/3.4 = 1.7$ and $F_{0.05}(1000, 380) = 1.35$, $F > F_{0.05}$, the data tentatively support the conclusion that a reduction in flotation inlet brightness variation has been achieved after implementation of the pulper head tank level controls. The evidence for a significant reduction in mill brightness variation due to the operation of the pulper head tank level controls should be considered tentative at this time. Most mills have good and bad months of process operation, and it is difficult to assess the importance of monthly variations in incoming waste paper quality, operator performance, and overall mill operation on recycle brightness control. Observation of a similar reduction in flotation brightness variation over a period of several months would provide conclusive support that the pulper head tank level controls have significantly reduced mill brightness variation.

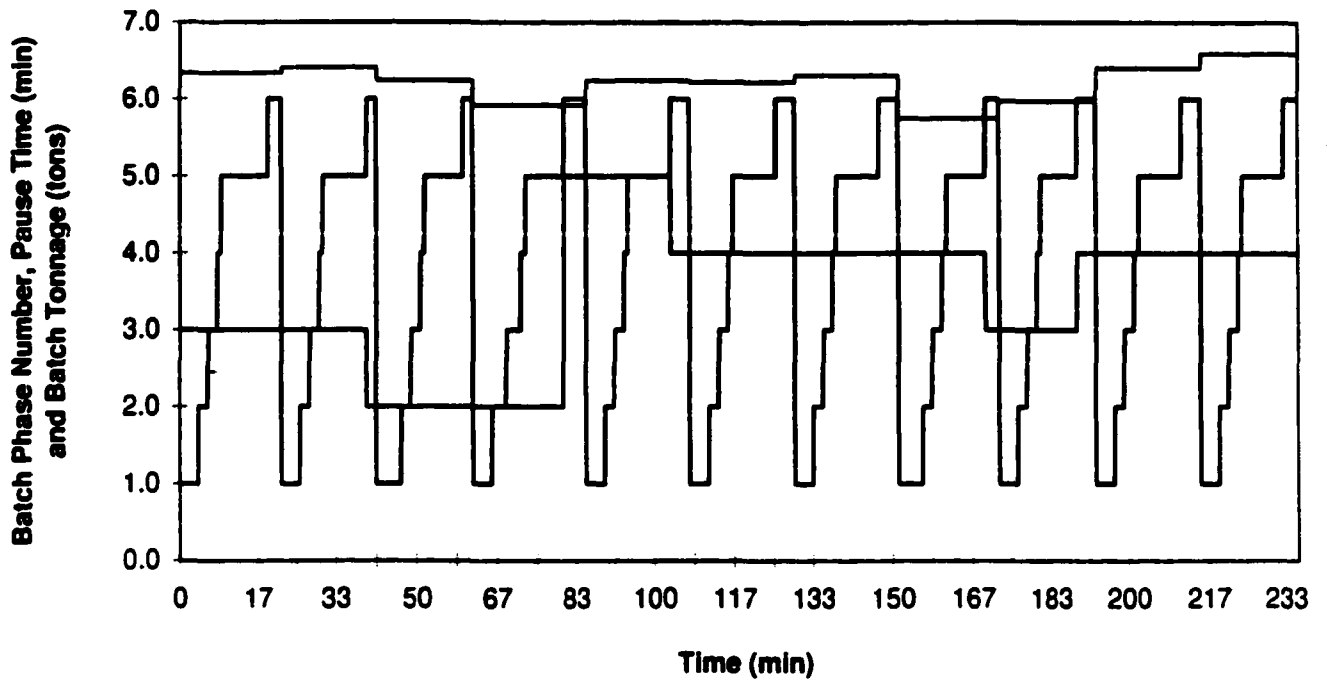

**Figure 5.20 Recycle Plant Process Data Showing Batch to Batch Tonnage Variation, Between Batch Pause Times and Phase Times for Figures 5.21, 5.22, 5.23 and 5.24
Initial Batch Tonnage = 6.4 tons; Initial Pause Time = 3.0 min**

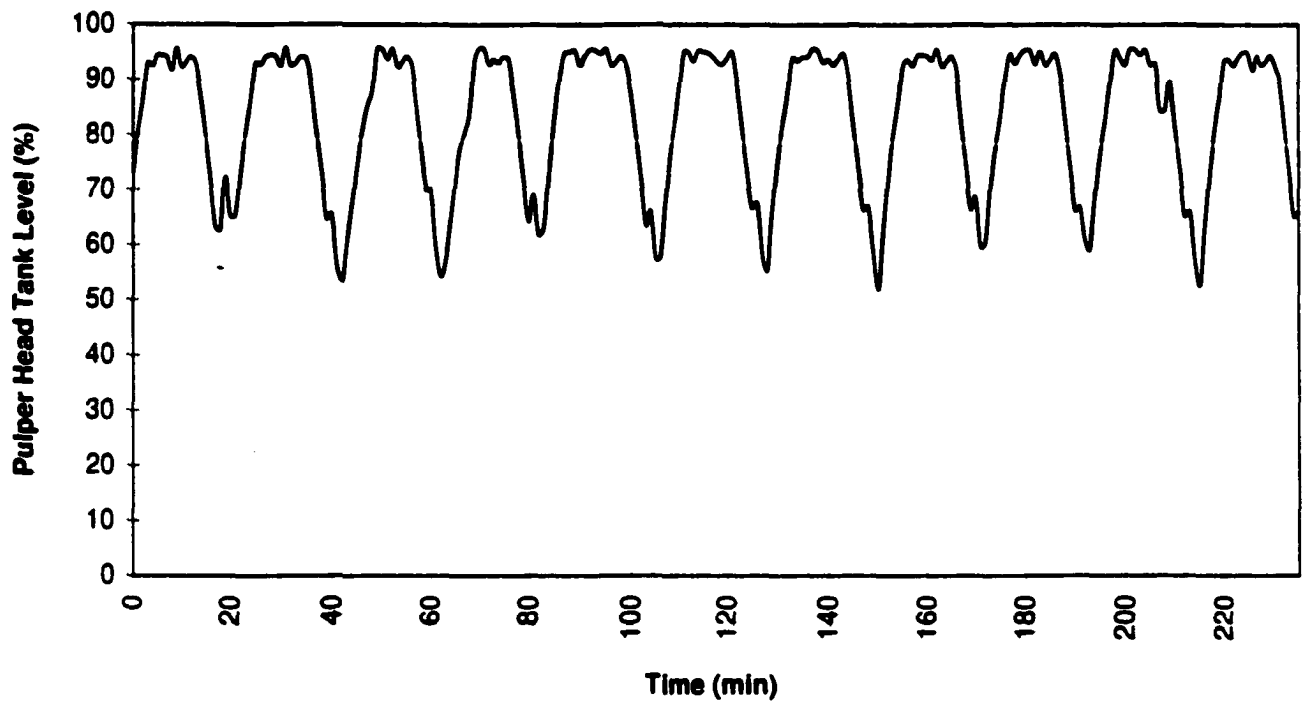

Figure 5.21 Avenor Pulper Head Tank Level Control With Between Batch Pause Delays and Batch Tonnage Variation

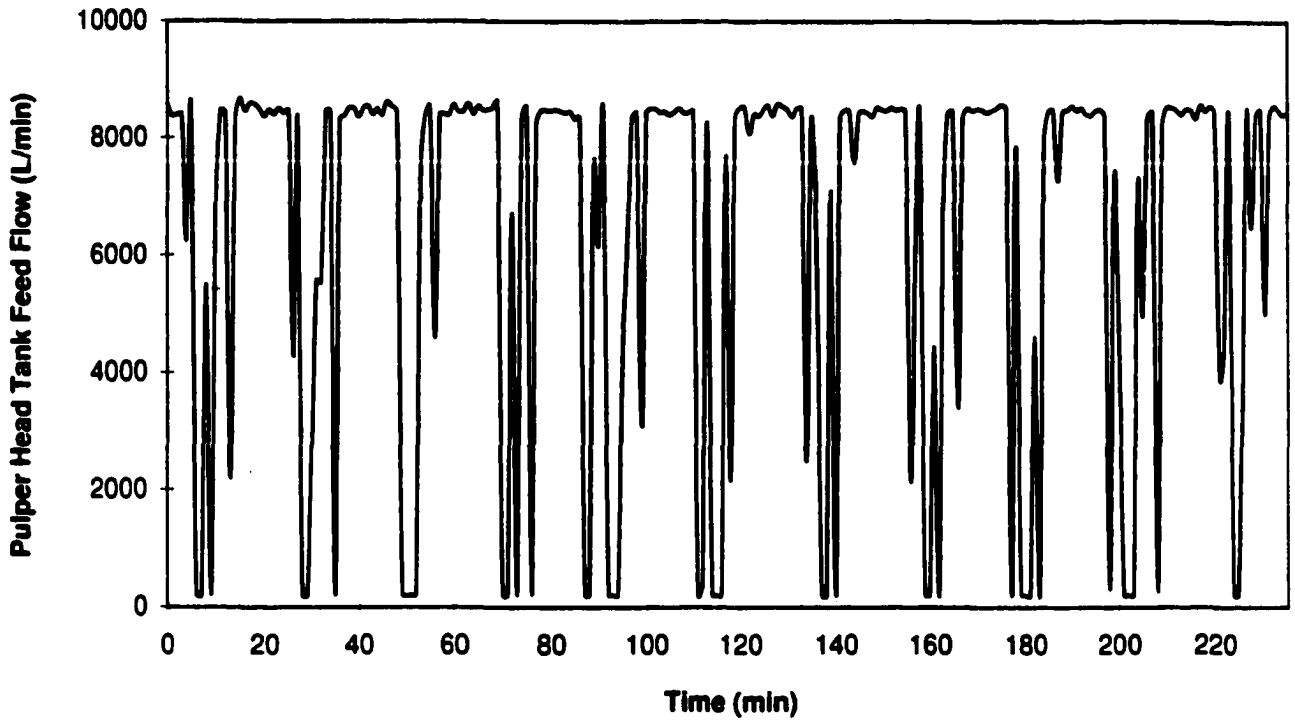

Figure 5.22 Avenor Pulper Head Tank Feed Flow Variation With Between Batch Pause Delays and Batch Tonnage Variation

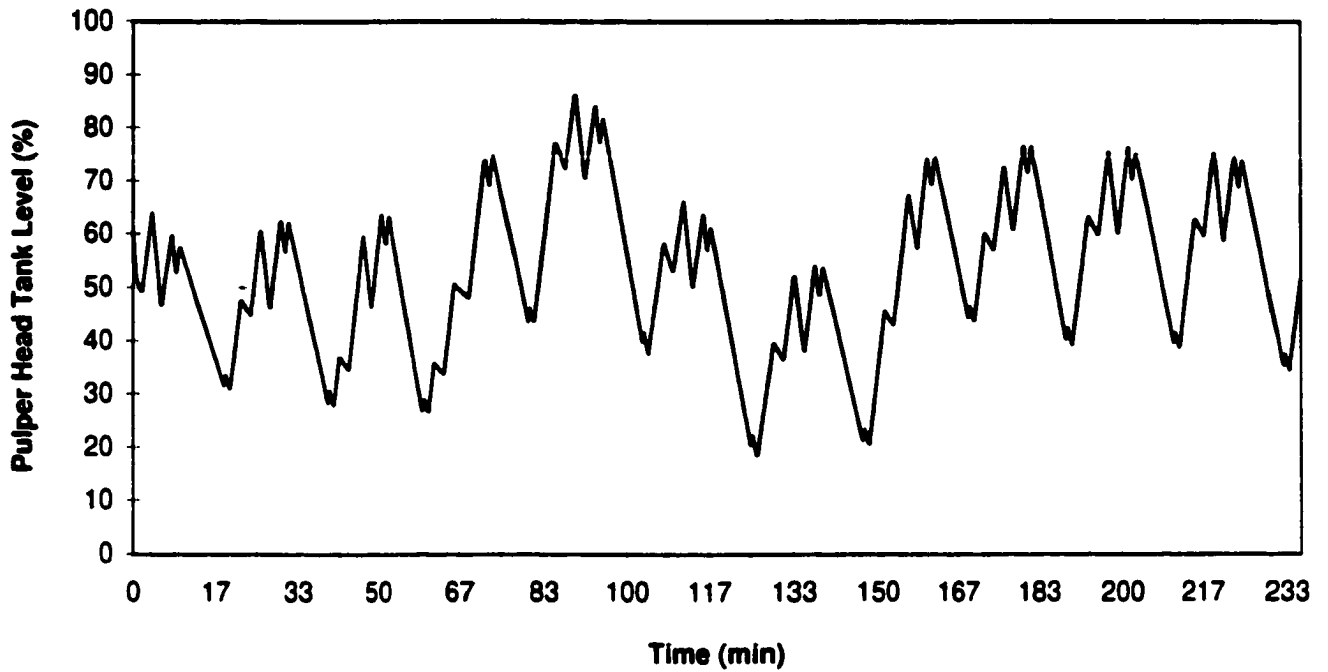

Figure 5.23 Feed Forward Pulper Head Tank Level Control With Between Batch Pause Delays and Batch Tonnage Variation

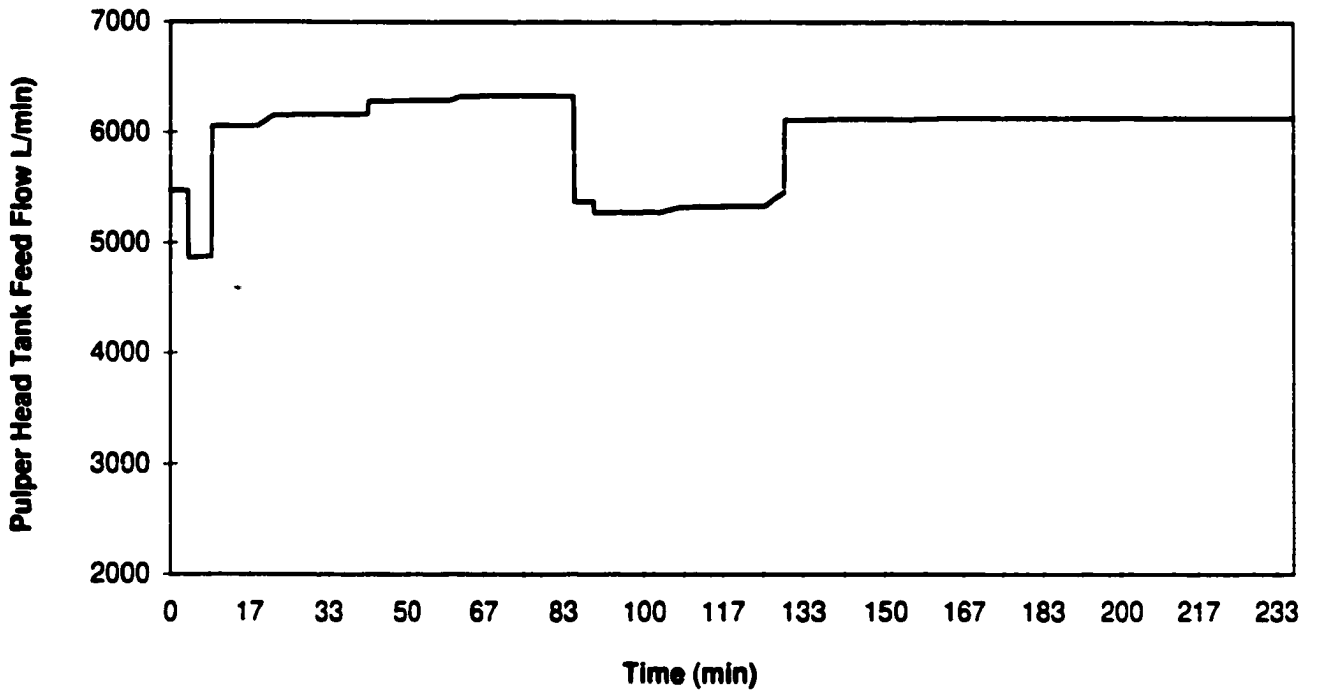

Figure 5.24 Feed Forward Pulper Head Tank Feed Flow Variation With Between Batch Pause Delays and Batch Tonnage Variation

Table 5.0 Summary of Pulper Head Tank Feed Flow Variation Under Standard and Feed Forward Control Strategies

	Standard Deviation In In Pulper Head Tank Feed Flow (FIC101) (L/min)	Average Flow (L/min)
Feed Forward Batch to Batch Tonnage Variation	291	6470
Feed Forward With Between Batch Pausing Delays:		
With no Flow Controller offset	414	6250
With +5% Flow Controller offset error (Over supply)	437	6110
With -5% Flow Controller offset error (Under supply)	480	6520
Comparison of Head Tank Level Control Strategies with Avenor Process Data		
Avenor Head Tank Level Controls	3203	6450
Feed Forward Level Controls	338	6010
Typical Pulper Head Tank Feed Flow Variation At Avenor (8 hour time period)	2600-3400	

Chapter 6

Conclusions and Future Directions

This thesis examined opportunities for improving process performance through the implementation of supervisory controls systems which enable better use of the available on-line process data. The availability of on-line distributed control systems enable real time monitoring and control of key process variables. In many situations however, process measurements are used for periodic process monitoring rather than for control purposes. As shown in the automation of the talc conveyor metering system, the batch pulper discharge consistency control system, and the feed forward pulper head tank level control system, many of these on-line measurements can be harnessed to make improvements in process operation and control.

Many key variables implicated in mill control remain uninvestigated for their potential to improve mill production quality and variance. In particular, the impact of process variables on brightness control remain largely unexamined. The measurement of chemical addition, changing waste paper quality and production rate provide real time information that could potentially be used to predict and compensate for low quality production or reduce chemical costs. The impact of major areas of mill operation such as screening, flotation, clarification and mill water quality, and pulping on key quality parameters such as brightness gain, contaminant removal, stock losses, stickies control remain largely unexplored. The optimal level of many parameters, currently available for measurement such as clarifier chemical addition and turbidity, screen reject rates, pulper chemistry, flotation chemical addition, and cleaner consistency, have not been investigated with reference to their interaction with overall mill performance. Available process data is therefore potentially being wasted except for occasional troubleshooting.

The ability to measure and control many of these parameters provides the opportunity for greater real time process experimentation with readily implemented factorial designed experiments. Presently process variables are measured with reference to controlling them at pre-determined values. However, such automated controls are not presently used to investigate the effects of process changes on mill performance. With a more systemic investigation of the potential use of currently available on-line process measurements, opportunities for better use of process information available with distributed control system technology will provide further opportunities for control automation and mill integration.

Appendices

APPENDIX A

Talc Metering Control Sequence Code Algorithm Independent Sequence Block: RN_TALC:TALC986.s

```

INDEPENDENT_SEQUENCE( *****
**                                                                 **
**          INDEPENDENT SEQUENCE                               **
**          CONTROL BLOCK                                     **
**          CONTROLS TALC FEEDRATE                           **
**          FROM SCREW CONVEYOR                               **
**          TALC986.s                                         **
**          HISTORY: REV.0 16/12/96                           **
***** )

CONSTANTS ( *****
*          specify any Constants                               *
*          in the following format:                           *
*****
*          12_char_name = value ;                             *
***** )

{
  N          = 150; }      {Maximum Array Size}
{
  VOL_RET    = 625000.0; } {Retention Chest Tank Volume In Litres}
{
  VOL_AERATION = 300000.0;
  VOL_CRSC    = 50000.0;
  CS_RET      = .046 }    {Consistency In Retention Chest}
{
  DIL_MAX    = 900.0; }   {Max Flow From Fv205}
  BAG_WT     = 1066.8 ;   {Talc Bag Wt in kg}
  UPDATE     = 0.6;      {An Adjustable Value -Takes(x*100)%}
                                     {Of The New Screw Parameter}
                                     {And 100-x% Of The Previous Screw
                                     Parameter}
  SMPL_TIME  = 3.0;      {Sampling and Update time = 3.0 min}

VARIABLES ( *****
*          specify any Block Local Variables                 *
*          in the following format:                           *
*****

```



```

*      12_char_name [ , 12_char_name ] : type;          *
*
*      where type is one of B, I, R, S, S12, S6          *
*****}

```

```

SC_PAR      : R ; { Adjusted Screw Constant: Relates The Talc
                Screw Speed To The Talc Feedrate }
SC_PAR_L    : R ; { Stored Previous SC_PAR Value }
INT_SC_SPEED : R ;
INT_TALC_RT : R ; { Integrated Talc Feedrate }
COUNT1     : R ; { Counter To Track Boolean Updates }
COUNT      : R ; { Counter To Track Operator Alerts }
TEMP        : R ; { A Temporary Storage Variable placeholder }
INT_TALC     : R ; { Total Talc Recycled To Disperger }
TALC_RATIO  : R ; { Talc/fibre Ratio When Correctly Estimated }
LT201_L     : R ; { Level From Previous Time Period }
LIC318_L    : R ;
LIC503_L    : R ;
{ LAG_TIME   : R ; } { Recirculation time Delay back to Disperger inlet }
{ LAG_TIME_L : R ;
TALC_RET    : RA; } { Declaring A Real Array }
{ I         : I ;
INDEX      : I ; }
LOOPS      : I ; { Sums No. of Time Periods Between Talc cycles }
LAST_BAG   : B ; { True if Prior Talc Bag Change Was Correctly
                Recorded }
RE_INIT    : B ; { Initialization for Program Start }

```

```

USER_LABELS { *****
*      specify any user labeled parameters          *
*      in one of the following formats:             *
*****}
* 10_char_name : BI00nn; n = 01 -- 24              *
* 10_char_name : BO00nn; n = 01 -- 16              *
* 10_char_name : BA000n; n = 1 -- 4                *
* 10_char_name : RI00nn; n = 01 -- 15              *
* 10_char_name : RO00nn; n = 01 -- 15              *
* 10_char_name : RA000n; n = 1 -- 2                *
* 10_char_name : II000n; n = 1 -- 8                *
* 10_char_name : IO000n; n = 1 -- 5                *
* 10_char_name : IA0001;                            *

```

* 10_char_name : SN00nn; n = 01 -- 10 *
 ***** }

SC_SP_SPT : RO0001; {Setpoint for talc screw speed controls}
 {LAG_TIME : RO0002;} {Talc Recirculation Lag time period}
 TALC_RAT : RO0004; {Talc/fibre ratio during Last talc Bag cycle}
 SC_SPEED : RI0001; {As Measured as a percent of Maximum}
 TALC_SPT : RI0002; {Typically 1.5% wt/wt on dry pulp}
 KIC905 : RI0003;
 FT906 : RI0004;
 HV910 : RI0005; {Recirculation Valve Position: 1=open}
 FY919 : RI0006;
 INT_TPD : RI0007; {Integrated production rate}
 LT201 : RI0008; {Retention Chest Level}
 KV205 : RI0009;
 FIC220 : RI0010;
 FY222 : RI0011; {Retention Chest Production Rate}
 LIC318 : RI0012;
 FT400 : RI0013;
 LIC503 : RI0014;
 RN_TPD : RI0015; {Twin-Wire Press Production Rate}
 FFIC206 : II0001;
 {HD_INFLOW : II0002;} {Feed Flowrate to H.D. Storage}
 BAG_CHG : BI0001; {Indicate a Talc Bag Change}
 BAG_CORR : BI0002; {Correct Bag Change?}
 AUTO_MAN : BI0003; {Auto Or Manual talc Metering Control}
 {TRUE when in AUTOMATIC}
 {PLANT_DOWN : BI0004;} {TRUE If Plant is Down}
 {CONVEY_ON : BI0005;} {TRUE If Conveyor Is on}
 TALC_CHK : BO0001; {OPERATOR ALERT}
 INT_RESET : BO0002; {Reset FQ986 To Zero}

{ *****
 * Specify any Subroutines *

 * *
 * SUBROUTINE name (formal arguments) ; *
 * VARIABLES subr. local variables ; *
 * STATEMENTS; *
 * ENDSUBROUTINE *
 ***** }

```

{ *****
*   Specify any                               *
*   Standard Block Exception Handlers         *
*****
*
* BLOCK_EXCEPTION exc_name [ DISABLE ]      *
* STATEMENTS;                               *
* ENDEXCEPTION                               *
***** }

```

```

STATEMENTS { *****
*   Specify the statements here             *
***** }

```

{ Initialize all variables on start-up }

```

INT_TALC_RT   := 0.0;      { Initialization }
INT_SC_SPEED  := 0.0;
INT_TALC      := 0.0;
BAG_CHG       := FALSE;
LAST_BAG      := FALSE;   { Assume initialization not done at a talc
                           change time -hence can't be used to update
                           screw calibration }

INT_RESET     := TRUE;    { Set Integrated TPD To Zero }
INT_RESET     := FALSE;
COUNT1       := 0.0;
COUNT        := 0.0;
LOOPS         := 0;
LT201_L       := LT201;
LIC503_L      := LIC503;
LIC318_L      := LIC318;
RE_INIT       := TRUE;    { Reinitialize to startup program }

```

{ Initialize storage array containing updated talc recirculation rates }

```

{
  I := N;
  WHILE (I > 0) DO
    TALC_RET[I] := 0.0;
  I := I-1;
}

```

```
ENDWHILE;  
HV910_LAST := HV910;}
```

```
<<START>>
```

```
{CHECK TO SEE IF PLANT IS RUNNING AND TALC CONVEYOR IS ON}  
{IF ( PLANT_DOWN) THEN  
    WAITUNTIL (PLANT_DOWN = FALSE);  
ENDIF;
```

```
IF (NOT (CONVEY_ON)) THEN  
    WAITUNTIL (CONVEY_ON =TRUE); {Wait until screw conveyor is activated}  
ENDIF;}
```

```
IF (RE_INIT=TRUE) THEN  
    IF (SC_SPEED < .1) THEN  
        RE_INIT :=TRUE;  
        GOTO START;  
    ENDIF;
```

```
SC_PAR := (RN_TPD*TALC_SPT)/(144.0*SC_SPEED);  
        { Assume screw is operating properly }
```

```
SC_PAR_L := SC_PAR;  
LAST_BAG := FALSE; {Initialization usually not done during a talc bag  
                    change}
```

```
RE_INIT := FALSE; {Reset Re_init to wait for next toggle}  
ENDIF;
```

```
IF ((NOT BAG_CHG) OR (COUNT1 > 0.1)) THEN  
    GOTO OK ; {Jump Out Of Screw Update Loop If No BAG_CHG}  
ENDIF;
```

```
COUNT1 := COUNT1 + 1.0; {Add To Counter To Protect Against  
                        Operator Double Toggling}  
WAIT 10; {Wait To Allow Operator To Toggle All  
         Controls}
```

```
IF (INT_TPD >0.0) THEN  
    TALC_RAT := (BAG_WT/(INT_TPD*1000.0))*100.0;  
ENDIF;
```

```

IF ((INT_TPD > 0.0) AND BAG_CORR AND LAST_BAG) THEN
  TALC_RAT1 := (!066.8/(INT_TPD*1000.0))*100.0;
  {TALC_RAT := ((1066.8+INT_TALC)/(INT_TPD*1000.0))*100.0;}
ELSE
  TALC_RAT1 := TALC_SPT;      {An Error In INT_TPD Has Occurred
                              Due to operator error during talc change}
ENDIF;

{IF (LOOPS > N) THEN
  LOOPS := N;}              {Protect Against Exceeding Array Size}
{ENDIF;}

IF (BAG_CORR AND LAST_BAG) THEN
  FOR I:= 1 TO LOOPS DO
    TALC_RET[I] := TALC_RET[I]*(TALC_RAT/TALC_SPT);
  ENDFOR;} {Adjusts For Error Between TALC_SPT And The Measured
           Talc/fibre Ratio}
{ENDIF;}
{LOOPS := 0;}      {Reset LOOPS Counter To Zero For Next Talc Bag}
{ENDIF;}

IF ((BAG_CORR ) AND (LAST_BAG)) THEN {Okay to recalibrate screw model}

  IF (INT_SC_SPEED > 0.0 )THEN
    SC_PAR := UPDATE*(BAG_WT/INT_SC_SPEED)+SC_PAR_L*(1-
                                         UPDATE);

  ELSE
    RE_INIT := TRUE; {INT_SC_SPEED Must Be > 0.0}
    GOTO START;
  ENDIF;

  LAST_BAG := TRUE;
ELSE
  LAST_BAG := BAG_CORR;
ENDIF;

IF (SC_PAR < 0.0001) THEN
  SC_PAR := SC_PAR_L;
ELSEIF (SC_PAR > 10.0) THEN
  SC_PAR := SC_PAR_L;
ENDIF;

```

```

SC_PAR_L      := SC_PAR;
INT_TALC      := 0.0;      {Reset Total Talc Recycled To Disperger To Zero}
INT_TALC_RT   := 0.0;      {Reset Talc Use To Zero For New Bag}
INT_SC_SPEED  := 0.0;      {Reset Screw Speed Integration To Zero}
INT_RESET     := TRUE;     {Reset The Integrator To Zero}
WAIT 1;
INT_RESET     := FALSE;

```

<<OK>>

```

IF (INT_TALC_RT >1069.0 ) THEN  {One Talc Bag weighs 1075 kg}
  IF (COUNT = 0.0) THEN
    TALC_CHK := TRUE; {ALERTING OPERATOR}
    WAIT 10;
    TALC_CHK := FALSE;
    COUNT := COUNT + 1.0;
  ENDIF;
  IF COUNT > 4.9 THEN {RE-ALERT OPERATOR EVERY 5TH PERIOD}
    COUNT := 0.0;
  ENDIF;
ENDIF;

{IF (HV910 = 0.0) OR (HV910_LAST =0.0) THEN
  RECYCLE := 0.0; {No pulp recirculation}
ELSEIF (HV910 >99.9) THEN }{If 100% Recycle Then Ignore HD_INFLOW}
{  RECYCLE := FT906;
ELSE
  RECYCLE := FT906-HD_INFLOW;
ENDIF;
IF (RECYCLE < 0.0) THEN
  RECYCLE := 0.0;
ENDIF;}

{Store Recycle Data in Array form and update the most recent measurment to array}
{I:=N;
WHILE (I>1) DO
TALC_RET[I] := TALC_RET[I-1];
I:= I-1;
ENDWHILE;
TALC_RET[1] := (KIC905/100.0)*RECYCLE*(TALC_SPT/100.0);}

```

{Calculate Current Process Lag Time from Current Plant Inventory and Production Rate}

```
{IF (FFIC206 < 100.0) THEN
    FFIC206 :=0.0;
ENDIF;

LAG_RET1 :=((LT201*VOL_RET*CS_RET)/(100.0*(FY222/1.440)));
LAG_CRSC :=(LIC318*VOL_CRSC/(100.0*(FIC220-VOL_CRSC*(LIC318-
    LIC318_L)/(100.0*SMPL_TIME)));
LAG_AER := LIC503*VOL_AERATION/(100.0*(FT400-
    VOL_AERATION*(LIC503-LIC503_L)/(100.0*SMPL_TIME)));

LAG_TIME :=LAG_RET1+ LAG_CRSC+LAG_AER+5.0;}

{IF ((FT400 < .1) OR (FY222 < 1.0)) THEN
    LAG_TIME := LAG_TIME_L;
ENDIF;

IF (LAG_TIME < 0.0) THEN
    LAG_TIME := 0.0;
ELSEIF (LAG_TIME > SMPL_TIME*N) THEN
    LAG_TIME := SMPL_TIME*N;
ENDIF;

LT201_L := LT201;
LT318_L := LT318;
LT503_L := LT503;
LAG_TIME_L := LAG_TIME;
INDEX := ROUND(LAG_TIME/SMPL_TIME);}
{INDEX determines the correct array position to read the talc recirculation flow now
feeding the disperger}

{IF (FY919 > 100.0) OR (FY919 <50.5) THEN
    FY919 := 100.0;
ENDIF;

INT_TALC := INT_TALC + (FY919/100.0)*TALC_RET[INDEX]*SMPL_TIME;
TEMP := ((RN_TPD/1.44)*(TALC_SPT/100.0)-(FY919/100.0)*TALC_RET[INDEX])/
    SC_PAR;}
TEMP := (TALC_SPT*RN_TPD)/(144.0*SC_PAR); {Used for variable storage}
```

```

IF (TEMP > 100.0) THEN
  SC_SP_SPT :=100.0;
  ELSEIF (TEMP < 0.0) THEN
  SC_SP_SPT := 0.0;
  ELSE
  SC_SP_SPT := TEMP;
  ENDIF;

```

{Monitor the talc screw speed and estimate the total addition of talc during the current talc cycle}

```

IF (AUTO_MAN ) THEN
  INT_TALC_RT := INT_TALC_RT + (SC_SP_SPT*SC_PAR*SMPL_TIME);
  INT_SC_SPEED := INT_SC_SPEED + (SC_SP_SPT*SMPL_TIME);
ELSE
  INT_TALC_RT := INT_TALC_RT + (SC_SPEED*SC_PAR*SMPL_TIME);
  INT_SC_SPEED := INT_SC_SPEED + (SC_SPEED*SMPL_TIME);

```

```

ENDIF;

```

```

IF (BAG_CHG AND (COUNT1 >.1)) THEN
  COUNT1 := COUNT1 +1.0; {Increment The Counter}
ENDIF;

```

```

IF (COUNT1 >9.0) THEN
  BAG_CHG := FALSE;      {The Booleans Are Only Reset After 9*3 Min to Prevent
                          the Operator from Double-Toggling the Reset Button}

```

{Reset BAG_CHG and BAG_CORR to False for next talc cycle}

```

BAG_CORR := FALSE;
COUNT1 := 0.0; {Count1 Is Set Back To Zero; Now Ready to Accept A New
                 Talc Bag Change As Legitimate}

```

```

ENDIF;

```

{LOOPS := LOOPS+1;} {Increment The Sample Periods/bag Counter}

```

WAIT 180;      {There is a 3 minute sampling and update period}

```

```

GOTO START;

```

ENDSEQUENCE

APPENDIX B

Pulper Discharge Consistency Control Sequence Code Algorithm Dependent Sequence Block: RN_PULPER:PULPER_CONS.s

```
DEPENDENT_SEQUENCE{*****
**                                     **
**   DEPENDENT SEQUENCE CONTROL       **
**     BLOCK REGULATES THE PULPER     **
**   DILUTION FLOWRATE                **
**   DURING PULPER EMPTYING.         **
**   IMPLEMENTED TO CONTROL           **
**   STOCK DILUTION CONSISTENCY      **
**   DURING PULPER DISCHARGE         **
**   HISTORY: REV.0 05/01/98         **
**   REV.1 30/03/98                  **
**   REV.2 09/04/98                  **
*****}
```

```
CONSTANTS {*****
*   specify any Constants             *
*   in the following format:          *
*****
*   constant_name = value ;           *
*****}
```

```
SAMP_T    = 4.0;      {Sampling Time For Loop, Sec.}
N         = 6;        {Array Size For Level Chg. Calc.}
SAMP_PTS  = 6.0;     {Number Of Samplings Pts Used}
```

```
VARIABLES {*****
*   specify any Block Local Variables *
*   in the following format:          *
*****
*   variable_name [, variable_name] : type; *
* * * * * * * * * * * * * * * * * * * * * * *
*   where type is one of B, I, R, S, S12, S6 *
* * * * * * * * * * * * * * * * * * * * * * *
```

***** }

PH5_TIMER_A : R;
VOL_CH_CAL : R; {Most Recent Estimate Of Pulper Volume Change}
NEW_DCHG_RT : R; {Calculation of Initial Pulper Discharge Flow}
DEN : R; {Least Squares Parameters}
NUM : R; {Least Squares Parameters}
K1 : R;
K2 : R;
DETR_TIME : R; {Detrasher Time - Set FT123 to Zero}
SUM_XY : R; {Least Squares Variables}
SUM_Y : R;
SUM_XSQD : R;
SUM_X : R;
TEST : R;
FLAG_143 : B; {Detects Opening Of HV143 To Retention Chest}
FT123_F : R;
FT115_F : R;
LT116_F : R; {Filtered Measurement of Pulper Level, LT116}
DETR_DIL : R; {Detrasher Pre_dilution Water Phase 4}
PULP_LEFT : R; {Calculates Amount of Pulp Left after dilution limit reached}
WATER_EXCESS : R; {Excess water added beyond dilution requirements}
FLAG1 : B;
flag_2 : B;
PULPVOL : I[N]; {Volume Of Stock In Pulper-Phase 5}
PH_NO_LAST : I; {To Keep Track Of Phase Changes}
TIMESTART : R; {Time From Which HV143 Opens}

USER_LABELS{*****}

* specify any user labeled parameters *
* in one of the following formats: *

* usr_label_name : BI00nn; n = 01 -- 24 *
* usr_label_name : BO00nn; n = 01 -- 16 *
* usr_label_name : BA000n; n = 1 -- 4 *
* usr_label_name : RI00nn; n = 01 -- 15 *
* usr_label_name : RO00nn; n = 01 -- 15 *
* usr_label_name : RA000n; n = 1 -- 2 *
* usr_label_name : II000n; n = 1 -- 8 *
* usr_label_name : IO000n; n = 1 -- 5 *
* usr_label_name : IA0001; *

* usr_label_name : SN00nn; n = 01 -- 10 *
 ***** }

PULPER_LVL	: RI0001;	{Pulper Level LT116}
PH5_TIMER	: RI0002;	{TMR_5A.TIMR1}
FQ115_A_5	: RI0003;	{Flow Accumulator}
FQ123_A_5	: RI0004;	{Flow Accumulator}
FT123	: RI0006;	{Pulper Dischg Line Dilution Flow}
PH4_CS	: RI0007;	{Final Pulp Consistency Entering Phase 5}
FT115	: RI0008;	{Pulper Dilution Flow}
PH5_CS	: RI0009;	{Setpoint Consistency For PH_5 Discharge}
FT162	: RI0010;	{Flow Into Retention Chest--poor}
WQ113A	: RI0011;	{Batch Tonnage Accumulator}
PH6_DIL	: RI0012;	{Dilution Water Left Over For Phase 6}
GW_A_5	: RI0013;	{Grey Water Addn Phase 5}
BATCH_TIMER	: RI0014;	{TMR_5A.TIMR2}
HV143	: RI0015;	{Detrasher Outlet LineValve Position}
PULPER_VLV	: BI0001;	{Pulping Discharge Valve Open}
OPER_TOGG	: BI0002;	{Operator Toggle To Activate Block}
ENABLE_DIL	: BI0024;	{If True, PULP_MAIN_5 is On Dilution control}
PH_NO_1_5	: II0001;	{Current Batch Phase Number}
FT123SP	: RO0001;	{Setpoint For FT123 In Phass 5}
FT115SP	: RO0002;	{Setpoint For FT115 In Phase 5}
INIT_DCHG_RT	: RO0003;	
PUL_CONS	: RO0004;	{Consistency In Pulper-Phase 5}
VOL_RT_CH	: RO0005;	
LOOPS	: RO0006;	
CORR	: RO0007;	{Correction To Dilution Addition Flow}
DETR_MAX	: RO0008;	{3100 L Standard Phase 4 Detrasher Pre-Dilution}
BATCH_TIME	: RO0009;	
DISCHG_FL	: RO0010;	{L/min Pulper Discharge Flow Phase 5}
FQA_115_123	: RO0011;	{Total Dilution Water Addition - Phase 5}
GW_AA_5	: RO0012;	{Total Dilution Water Demand - Phase 5}
DISCHG_LST	: RO0013;	{Clamp On Discharge Flow Noise}
FQ123_5_MAX	: RO0014;	{FQ123A Dilution Water Addition In Phase 5}
FQ115_5_MAX	: RO0015;	
BEGIN	: BO0001;	
RESET	: BO0002;	
ENDTIME	: BO0003;	
MEAS_INIT	: BO0004;	{Controls Calculation of INIT_DSCHG to Once/batch}

```

END_TIME      : BO0005;
CORR_TEST    : BO0006;
SCRN_PLUG    : BO0007;   { Test To Detect Screen Blockage -Not Active}
DIL_DONE     : BO0008;   { Phase 5 Diution Water Total Completed}
WINDOW_ON    : BO0009;   { Operator Console Windows Active for Phase 5}
i            : IO0001;
PULPER_V1    : IO0002;
PULPER_V2    : IO0003;
PULPER_V3    : IO0004;

```

```

{ *****
* Specify any Subroutines                               *
*****}
*
* SUBROUTINE name ( formal arguments ) ;               *
* VARIABLES subr. local variables ;                   *
* STATEMENTS                                           *
* ENDSUBROUTINE                                       *
*****}

```

```

{ *****
* Specify any                                         *
* Standard Block Exception Handlers                   *
*****}
*
* BLOCK_EXCEPTION exc_name [ DISABLE ]               *
* STATEMENTS;                                         *
* ENDEXCEPTION                                       *
*****}

```

```

STATEMENTS { *****
* Specify the statements here                         *
*****}

```

```

{INITIALIZATION}
SUM_Y      :=0.0;
SUM_XY     := 0.0;
BEGIN      := TRUE;

```

```

FLAG1           := TRUE;
DETR_DIL        := 0.0;
DETR_MAX        := 0.0;
LOOPS           := 0.0;
CORR            := 1.0;
NEW_DCHG_RT     := 0.0;
FT115SP         := 55.0;
SCRN_PLUG       := FALSE;
TEST            := 0.0;
TIMESTART       := 0.0;
FLAG_143        := TRUE;
flag_2          := TRUE;

```

```
<<START>>
```

```

IF (BEGIN = TRUE) THEN { Initialize Value For Pulper Discharge Rate }
    INIT_DCHG_RT := 4000.0;
ENDIF;

```

```

N := TRUNC(30.0/SAMP_T);    { Number Of Sampling Periods For Calculation of
                             Pulper Dishcarge Rate }

```

```
FOR i := 1 TO N DO
```

```

    SUM_X := SUM_X + (i)*SAMP_T;
    SUM_XSQD := SUM_XSQD + (i)*(i)*SAMP_T*SAMP_T;

```

```
ENDFOR; { X Values Only Need To Be Calculated Once }
```

```
{ ACTIVATE BATCH TIMER }
```

```
:RN_PULPER:TMR_5A.TIMR2V :=0.0;
```

```
START_TIMER (:RN_PULPER:TMR_5A.TIMR2);
```

```
<<DIL_LOOP>>
```

```

IF (FT115_F > 12000.0) THEN
    FT115_F := 12000.0;
ENDIF;

```

```

IF (FT115_F < 100.0) THEN
    FT115_F := 0.0; { Eliminate Noise Bias }
ENDIF;

```

```

DETR_DIL := FQ123_A_5;
PH5_TIMER := PH5_TIMER; {Update The Tracking Timer}
BATCH_TIME := BATCH_TIMER;
IF (PH_NO_1_5=1) THEN
  IF (FLAG1=TRUE) THEN
    STOP_TIMER (:RN_PULPER:TMR_5A.TIMR2);
    :RN_PULPER:TMR_5A.TIMR2V := 0.0;
    BATCH_TIME := 0.0;
    START_TIMER (:RN_PULPER:TMR_5A.TIMR2);
    FLAG1 :=FALSE;
  ENDIF;
ENDIF;

```

```

IF (PH_NO_1_5 =4) AND (DETR_DIL > DETR_MAX) THEN
  FLAG1 := TRUE; {Reset BATCH_TIMER Flag}
  DETR_MAX := DETR_DIL;
  DETR_TIME := 10.0*(DETR_MAX/3000.0);
  IF (DETR_TIME >20.0) THEN
    DETR_TIME := 20.0;
  ENDIF;
ENDIF;

```

{Calculate Pulper Volume Change Rate}

```

IF ((PH_NO_1_5 = 4) OR (PH_NO_1_5 = 5)) THEN
  LT116_F := PULPER_LVL;
  {5 Second Noise Filter Placed On LT116 Transmitter Loop}
  FOR i := 1 TO N-1 DO

    PULPVOL[i] := PULPVOL[i+1];

  ENDFOR;

```

{PULPVOL[N] Is The Most Recent Estimate Of Pulper Volume}

```

PULPVOL[N] := TRUNC(3.24*(LT116_F)*(LT116_F)+598.8*(LT116_F)); {Litres}
PULPER_V1 := PULPVOL[N];
PULPER_V2 := PULPVOL[N-1];
PULPER_V3 := PULPVOL[N-2];

```

{Calculate Least Squares Data For Pulper Discharge Flow}

SUM_XY := 0.0;

SUM_Y := 0.0;

FOR i := 1 TO N DO

 SUM_Y := SUM_Y + PULPVOL[i];

 SUM_XY := SUM_XY + (PULPVOL[i])*(i)*SAMP_T;

ENDFOR;

NUM := N*SUM_XY-SUM_X*SUM_Y;

DEN := N*SUM_XSQD-SUM_X*SUM_X;

IF (DEN > 0.1) THEN

 VOL_CH_CAL := ((NUM/DEN)*60.0); {Litres/min}

ENDIF;

{Update Filtered Estimate Of Pulper Volume Change}

VOL_RT_CH := ((VOL_RT_CH*3.0 + VOL_CH_CAL)/4.0);

IF (PULPER_VLV = FALSE) THEN

 IF (FT115_F < 100.0) THEN

 VOL_RT_CH := 0.0;

 ENDIF;

ENDIF;

{Calculate Dilution Water Demand For Phase 5}

{Filter FT115 And FT123 with Simple Lag Before Calculation}

FT115_F := ((FT115_F*2.0)+FT115)/3.0;

FT123_F := ((FT123_F*2.0)+FT123)/3.0;

ENDIF;

IF (PH_NO_1_5 = 4) THEN

 GW_AA_5 := GW_A_5; {From PULP_MAIN_5}

 IF (RESET = TRUE) THEN

 PUL_CONS := PH4_CS/100.0;

 {Initialize Pulper Consistency For Phase 5}

```

        RESET := FALSE; {Initialize Once Per Batch Only}
    ENDIF;
ENDIF;

{BEGIN STEP CALCULATION}

{PULPER CONSISTENCY CHECK}

IF (PH_NO_1_5=5) THEN

    IF (PULPVOL[N] > 100) THEN {Pulper Volume Cannot Be Zero}
        PUL_CONS := PUL_CONS + (1.0/(PULPVOL[N]*(1.0+PUL_CONS/(1.0-
        PUL_CONS))))*((FT115_F/60.0)*SAMP_T*(0.002-PUL_CONS));
    ENDIF;

    IF ((PUL_CONS < 1.10*PH5_CS/100.0) AND (PULPER_VLV=TRUE) ) THEN
        FT115SP := 0.0;
        :RN_PULPER:FIC115.SPT := 0.0; {FT115 Must Be Zero To Prevent Over
        Dilution}
    ENDIF;

ENDIF;

IF (PH_NO_1_5 =5) THEN

    GW_AA_5 := GW_A_5;

    {Calculate Dilution Demand-FT123 Litres/min}
    DISCHG_FL := (DISCHG_FL*3.0 + (FT115_F-VOL_RT_CH))/4.0; {Flow To Be Diluted}
    IF (DISCHG_FL < -1500.0) THEN
        DISCHG_FL := -1000.0;
    ENDIF;
    IF (PH5_TIMER > 110.0)
        IF (DISCHG_FL < 100.0) THEN
            FT123SP := 0.0;           {Detrasher Screens Are Plugged}
            :RN_PULPER:FIC123.SPT := FT123SP;
        ENDIF;
    ENDIF;
    IF (FLAG_143 = TRUE) THEN
        IF (HV143 >= 20.0) THEN
            TIMESTART := PH5_TIMER;
        ENDIF;
    ENDIF;
ENDIF;

```



```

        FLAG_143 := FALSE;
    ENDIF;
ENDIF;

IF (ABS(DISCHG_FL-DISCHG_LST) < 30) THEN
    DISCHG_FL := DISCHG_LST;
ELSE
    DISCHG_LST := DISCHG_FL;
ENDIF;

IF (FLAG_143 =FALSE) THEN  {HV143 Is Now Open}
    IF (PH5_TIMER >=(TIMESTART + DETR_TIME)) THEN
        IF (PH5_TIMER < 80.0) THEN

            IF (INIT_DCHG_RT < 1000.0) THEN
                INIT_DCHG_RT := 1000.0;
            ENDIF;

            IF (DISCHG_FL > INIT_DCHG_RT) THEN
                INIT_DCHG_RT := DISCHG_FL;
            ENDIF;

            FT123SP := CORR*INIT_DCHG_RT*PUL_CONS*((1-
                PH5_CS/100.0)/(PH5_CS/100.0)-(1-
                PUL_CONS)/PUL_CONS);
            :RN_PULPER:FIC123.SPT := FT123SP;
        ENDIF;
    ENDIF;

    IF (PH5_TIMER < (TIMESTART + DETR_TIME)) THEN
        FT123SP := 0.0; {Zero Dilution Flow Until Detrasher Water Is Flushed}
        :RN_PULPER:FIC123.SPT := FT123SP;
    ENDIF;
ENDIF;

IF (PH5_TIMER >=80.0) THEN
    IF (CORR_TEST = TRUE) THEN
        IF (FQ123_5_MAX > (0.97*GW_AA_5-FQ115_5_MAX)) THEN
            CORR_TEST := FALSE;
            PULP_LEFT := PUL_CONS*(3.24*(LT116_F)*(LT116_F)+598.8*(LT116_F));
                                                    {Litres}
        ENDIF;
    ENDIF;
ENDIF;

```

```
WATER_EXCESS := PULP_LEFT*((100.0/PH5_CS)-(1.0/PUL_CONS));  
CORR := 1-(WATER_EXCESS/GW_AA_5);
```

```
IF (CORR < 0.85) THEN  
    CORR := 0.85;  
ENDIF;
```

```
IF (CORR > 1.20) THEN  
    CORR := 1.20;  
ENDIF;
```

```
FT123SP := 0.0; {Prevents Phase 5 Overdilution}  
:RN_PULPER:FIC123.SPT := FT123SP;  
DIL_DONE := TRUE;
```

```
ENDIF;  
ENDIF;
```

```
IF (BEGIN = TRUE) THEN  
    IF ((PH5_TIMER >70) OR (DISCHG_FL > 500.0)) THEN
```

```
        {Calculate Initial Discharge Rate For Next Batch}
```

```
            BEGIN := FALSE;  
            NEW_DCHG_RT := 0.0;  
            LOOPS := 0.0;  
            MEAS_INIT := TRUE;
```

```
        ENDIF;  
    ENDIF;
```

```
IF (MEAS_INIT =TRUE) THEN
```

```
    IF (LOOPS <= SAMP_PTS ) THEN  
        NEW_DCHG_RT := NEW_DCHG_RT + DISCHG_FL;  
        LOOPS := LOOPS + 1.0;  
    ELSE  
        NEW_DCHG_RT := (NEW_DCHG_RT)/SAMP_PTS;  
        MEAS_INIT := FALSE;  
        INIT_DCHG_RT := NEW_DCHG_RT;  
    ENDIF;
```

```
IF (INIT_DCHG_RT < 500.0) THEN
```

```

        INIT_DCHG_RT :=1000.0;
    ENDIF;

ENDIF;
{Initial Pulper Discharge Rate Calculation Complete}

IF (DIL_DONE = FALSE) THEN
    {Calculate FT123 Setpoint}

    FT123SP := CORR*DISCHG_FL*PUL_CONS*((1.0-PH5_CS/100.0)/(PH5_CS/100.0)-
        (1.0-PUL_CONS)/PUL_CONS);

        IF (PUL_CONS < (1.06*PH5_CS/100.0) ) THEN
            FT123SP := 0.0; {Implemented Because FT123 Setpoint Response Is Slow}
        ENDIF;

        IF (FT123SP < 0.0) THEN
            FT123SP := 0.0;
        ENDIF;

        :RN_PULPER:FIC123.SPT := FT123SP;
    ENDIF;
ENDIF;

ENDIF;

IF (PH_NO_1_5 =5) THEN {FQ115A AND FQ123A Flow Accumulators}
    IF (FQ115_A_5 > FQ115_5_MAX) THEN
        FQ115_5_MAX := FQ115_A_5;
    ENDIF;

    IF (FQ123_A_5 >= FQ123_5_MAX) THEN
        FQ123_5_MAX := FQ123_A_5;
    ENDIF;

ENDIF;

ENDIF;

IF (PH_NO_1_5 = 5) THEN
    IF (PH_NO_LAST =4) THEN
        FQ123_5_MAX := 0.0;
        FQ115_5_MAX := 0.0;
    
```

```

    ENDIF;
ENDIF;
    FQA_115_123 := FQ123_5_MAX + FQ115_5_MAX;

IF (PH_NO_1_5 = 0) THEN
    IF (PH_NO_LAST = 5) THEN
        IF (CORR_TEST = TRUE) THEN
            CORR_TEST := FALSE;

            IF ((FQ115_5_MAX + FQ123_5_MAX) < GW_AA_5) THEN

                CORR := (1.0 * GW_AA_5 - FQ115_5_MAX) / FQ123_5_MAX;
            ENDIF;

            {RATIO OF PULPER DILUTION DEMAND TO ACTUAL WATER USED (FT123+FT115)}
            IF (CORR > 1.20) THEN
                CORR := 1.20;
            ENDIF;

            IF (CORR < 0.85) THEN
                CORR := 0.85;
            ENDIF;
        ENDIF;
    ENDIF;
ENDIF;

PH_NO_LAST := PH_NO_1_5; {Update Phase Delay}

{Check To See If Compactor Screens Are Plugging}
IF ((PH_NO_1_5 = 5) AND (PULPER_VLV = TRUE)) THEN
    IF (HV143 > 30.0) THEN
        IF ((FT115_F-VOL_RT_CH) < -1000.0) THEN {Screens Plugged ?}
            TEST := TEST + 1.0;
            IF (TEST >= 6.0) THEN {Assume Pulper Is Backing up}
                SCRN_PLUG := TRUE; {Drop Rate To 4000 L/min Until
                                    Unplugged}
                {Make Changes To Correct Plugging...}
            ENDIF;
        ELSE
            TEST := 0.0;
            SCRN_PLUG := FALSE;
        ENDIF;
    ENDIF;
ENDIF;

```

```
        ENDIF;  
    ENDIF;  
ENDIF;
```

{ Boolean Controls for Operator Window Displays During Phase 5 }

```
IF (PH_NO_1_5 =5) THEN  
    IF (OPER_TOGG = TRUE) THEN  
        WINDOW_ON := TRUE;  
        FQA_115_123 := FQ123_5_MAX + FQ115_5_MAX;  
    ENDIF;  
ENDIF;
```

```
IF (PH_NO_1_5 =0) THEN  
    WINDOW_ON := FALSE; { Turn Windows Off After Phase 5 }  
ENDIF;
```

```
IF (PH_NO_1_5 =1) THEN  
    WINDOW_ON := FALSE; { Turn Windows Off After Phase 5 }  
ENDIF;
```

```
IF (PH_NO_1_5 =6) THEN  
    WINDOW_ON :=FALSE;  
ENDIF;
```

```
IF (PH_NO_1_5 = 3) THEN  
    RESET           := TRUE; { Reset The Initial Pulper Consistency Discharge }  
    ENDTIME         := TRUE; { Reset Phase 5 Counters }  
    DETR_DIL        := 0.0; { Reset Detrasher Phase 4 Pre-dilution Volume }  
    DETR_MAX        := 0.0;  
    BEGIN           := TRUE;  
    CORR_TEST       :=TRUE;  
    FQ123_5_MAX     := 0.0;  
    FQ115_5_MAX     := 0.0;  
    LOOPS           := 0.0;  
    FLAG_143        := TRUE;  
    TIMESTART       :=0.0;  
    FT115SP         := 2.0; { Used During Testing Only }  
    DIL_DONE        := FALSE;  
    FQ115_5_MAX     := 0.0;  
ENDIF;
```

{ Operator To Automatic Control - If ENABLE_DIL = True Then Switch To Auto }

IF (OPER_TOGG = FALSE) THEN

 flag_2 := FALSE;

 WINDOW_ON := FALSE;

 :RN_PULPER:PULP_MAIN_5.BI0024 := FALSE;

ENDIF;

WHILE (flag_2 = FALSE) DO

 IF (OPER_TOGG = TRUE) THEN

 IF (PH_NO_1_5 = 1) THEN

 CORR := 1.0;

 :RN_PULPER:PULP_MAIN_5.BI0024 := TRUE;

 flag_2 := TRUE;

 ENDIF;

 ENDIF;

ENDWHILE;

WAIT UNTIL (BATCH_TIMER >= (BATCH_TIME+4.0)) AFTER 4.0 GOTO DIL_LOOP;

GOTO DIL_LOOP;

GOTO START;

ENDSEQUENCE

APPENDIX C

Pulper Head Tank Feed Forward Control Algorithm And Simulation Code

%A FILE TO SIMULATE THE PULPER HEAD TANK - PULPER FILLING CYCLE

%Matlab Coded Simulation of the Pulper Head Tank-Batch Pulper Filling Cycle and Feed

%Forward Control Algorithm on the Pulper Head Tank Feed Flow

clear

%Variable Initialization

```
BATCHCOUNT=0;           %Counting the Number of Batches Run
SIMU_TIME=18.0;          %Number of Batches to Be Simulated in Cycle
pause_test=1.0;          %Indicate Whether Batch Delays Will Occur
ton_var=0.0;             %For Trials with Batch to Batch Tonnage Variation
flow_offset=1.0;         %For Trials with Flow Controller Offset
factor=0.95;             %Equals 1+percent Offset of FIC101 From Setpoint Demand
PROD_CONTRL=1;
TOTAL_TIME=0.0;
TIMESTEP=1.0/60.0;       %Discrete Time Step Period in Minutes
PH_NO_1_5=0.0;          %Current Batch Phase Number
store_loop=1.0;
store_time=0.0;
VHDTK=80000.0;           %Total Head Tank Capacity In Litres
MAX_LEVEL=95.0/100;      %High Level Alert Limit For Pulper Head Tank
MIN_LEVEL=20.0/100;      %Low Level Alert Limit For Pulper Head Tank
FIC101_MAX=10000.0;      %High Limits for Pulper Head Tank Feed Flow Capacity
FIC101=7500.0;           %Initialize FIC101 Flow Rate
FIC3_TEST=0.0;
FIC_5_4END=0.0;
FIC_5_3END=0.0;
FIC_loop5=0.0;
FIC_5_5END=0.0;
FIC_CAP5=7000.0;
FIC_CAP4=7000.0;
FIC_LOW=7000.0;
FIC_STORAGE=6600.0;     %Stores Pulper Head Tank Feed Flow FIC101
PULPER_FL=0.0;           %Dilution Water Demand Flow to the Pulper
WATER_ACCUM=0.0;        %Initialize Batch Water Accumulator
```

ENDCAP5_3=0.0;
CAP5_1=0.0;
ENDCAP5_1=20.0;
ENDCAP5=0.0;
CAP5_3=0.0;
CAP4=60.0;
CAP5_1=75.0;
CAP2=45.0;

BEGIN=1;

%Batch To Batch Tonnage Profile (PROD_PLAN)

PROD_PLAN=[6.3*ones(1,33) 6.5 6.6 6.8*ones(1,4) 5.8*ones(1,3) 5.8 5.9 6.2 6.9*ones(1,17)];

TONNAGE=6.30; **%Initial Batch Pulper Tonnage**

TONNAGE_L=6.3; **%Last Batch Stored Tonnage**

%Batch Consistencies and Timing

PH2CONS=16.0; **%Phases 2 and 3 Consistency (%)**

PH4CONS=12.0; **%Phase 4 Consistency (%)**

PH5CONS=4.5; **%Discharge Consistency in Phase 5 (%)**

PH6_WAIT=0.3; **%Between Batch Pause Time (minutes)**

PH1TIME=3.05; **%Maximum Times for Each Phase Unless Paused**

PH2TIME=7.2;

%Phase 3 Slushing Time Setpoint (min)

PH3SPT=2.0;

PH3TIME=1.95;

PH4TIME=2.1;

PH5TIME=7.0;

PH5TIME_L=7.0;

PH6TIME=2.0;

PH5_TIMER=0.0;

PH3TIMER=0.0;

PH6_TIMER=0.0;

timer1=0.0;

**%In Conjunction with Control Algorithm; Used to Measure
%Phase Times**

TOTAL_TIME=0.0;

BATCH_TIME=0.0; **%Initialize Batch Time**

BATCH_TIME_L=20.0; **%Initialize Batch Time From Previous Batch**

BATCH_TIME_T=1.0;

BATCH_FLOW=0.0;

%Boolean Flags

```

timer_11=0.0;
timer_12=0.0;
timer_13=0.0;
timer_14=0.0;
timer_15=0.0;
testing=0.0;           %Flag for Phase 1 Control Calculations
phase1=1.0;           %Flag to Indicate Active/Inactive Phase
phase2=0.0;
phase3=0.0;
phase4=0.0;
phase5=0.0;
phase6=0.0;
check1=0.0;
check3=0.0;
count2=0.0;
count3=0.0;
count4=0.0;
count5=0.0;
count6=0.0;           %Flag for Phase 6 Control Calculations
loops=1.0;
looping=1;
flg1=0.0;             %Flag to Initialize Transition From Phase 1 to Phase 2
END5_DONE=0.0;
END5_3_DONE=0.0;
ENDPH5_DONE=0.0;     %Flag to End Phase 5 Calculations

```

%initialise Tank Volume and Level in Percent

```

LT102=63.0;           %Pulper Head Tank Level
HDTK_VOL=VHDTK*LT102/100.0; %Pulper Head Tank Volume (Litres)
high_level=0.0;      %High Level Flag for Pulper Head Tank

```

%Batch Phase Water Demands

```

PH1DEMAND= 15000.0;
PH2DEMAND= TONNAGE*1000.0*( (1-PH2CONS/100.0)/(PH2CONS/100.0) )
            -PH1DEMAND;
PH4DEMAND= TONNAGE*1000.0*( (1-PH4CONS/100.0)/(PH4CONS/100.0) )
            -PH2DEMAND -PH1DEMAND+3000;
PH5DEMAND= TONNAGE*1000.0*( (1-PH5CONS/100.0)/(PH5CONS/100.0) )
            -PH4DEMAND-PH2DEMAND-PH1DEMAND-8000.0;

```

```

PH6DEMAND=      8000.0;
PH6_WATER=      8000.0;

FIC_MEAN=       (PH1DEMAND+PH2DEMAND+PH4DEMAND+PH5DEMAND+
                 PH6DEMAND)/21.0;
FIC101=FIC_MEAN;      %Initialize Flow to the Average Batch Value

```

```

%-----
%OUTER LOOP OF SIMULATION: LOOPS ONCE PER TIME STEP

```

```

while ((BATCHCOUNT < SIMU_TIME) & (BATCH_TIME < 37.4)),

```

```

TOTAL_TIME=TOTAL_TIME+TIMESTEP;

```

```

%TIME STEP CALCULATIONS

```

```

%Pulper Operation - Phases 1-6

```

```

if (BEGIN==1)

```

```

    BATCHCOUNT=BATCHCOUNT+1      %Increment Batch Counter

```

```

    if (BATCHCOUNT > 39)

```

```

        BATCHCOUNT=0;

```

```

    end

```

```

    BEGIN=0;

```

```

        %Phase 1 Beginning

```

```

    BATCH_TIME=0.0;

```

```

        %Reset Batch_Time to Zero

```

```

%Read Tonnage for New Batch

```

```

if (PROD_CONTRL==1)

```

```

    TONNAGE=PROD_PLAN(BATCHCOUNT);

```

```

end

```

```

%Calculated Water Demands for New Batch

```

```

PH1DEMAND=      15000.0;

```

```

PH2DEMAND= TONNAGE*1000.0*((1-PH2CONS/100.0)/(PH2CONS/100.0) )
            -PH1DEMAND;
PH4DEMAND= TONNAGE*1000.0*((1-PH4CONS/100.0)/(PH4CONS/100.0) )
            -PH2DEMAND-PH1DEMAND+3000;
PH5DEMAND= TONNAGE*1000.0*((1-PH5CONS/100.0)/(PH5CONS/100.0) )
            -PH4DEMAND-PH2DEMAND-PH1DEMAND-8000.0;
PH6DEMAND= 8000.0;

```

```

end                                     %End of Begin Loop

```

```

%Batch Phase Timers to Be Used by Feed Forward Control Block to Monitor Phase Periods

```

```

if (PH_NO_1_5==1.0)
  if (timer_11==0.0)
    timer1=0.0;
    timer_11=1.0;
  end
  timer1=timer1+TIMESTEP;
end
if (timer_11==1.0)
  if (PH_NO_1_5~=1.0)
    PH1TIME=timer1;
    timer_11=0.0;
  end
end

```

```

if (PH_NO_1_5==2.0)
  if (timer_12==0.0)
    timer1=0.0;
    timer_12=1.0;
  end
  timer1=timer1+TIMESTEP;
end
if (timer_12==1.0)
  if (PH_NO_1_5~=2.0)
    PH2TIME=timer1;
    timer_12=0.0;
  end
end

```

```

if (PH_NO_1_5==3.0)

```

```

if (timer_13==0.0)
    timer1=0.0;
    timer_13=1.0;
end
timer1=timer1+TIMESTEP;
end
if (timer_13==1.0)
    if (PH_NO_1_5==4.0)
        PH3TIME=timer1;
        timer_13=0.0;
    end
end

if (PH_NO_1_5==4.0)
    if (timer_14==0.0)
        timer1=0.0;
        timer_14=1.0;
    end
    timer1=timer1+TIMESTEP;
end
if (timer_14==1.0)
    if (PH_NO_1_5==5.0)
        PH4TIME=timer1;
        timer_14=0.0;
    end
end

if (PH_NO_1_5==5.0)
    if (timer_15==0.0)
        timer1=0.0;
        timer_15=1.0;
    end
    timer1=timer1+TIMESTEP;
end
if (timer_15==1.0)
    if (PH_NO_1_5~=5.0)
        PH5TIME=timer1;
        if (PH5TIME >10.0)
            PH5TIME=PH5TIME_L;    %To Account for Non-characteristic Phase 5 Delay Times:
                                   %use Previous PH5Time for Next Batch
        else
            PH5TIME_L=PH5TIME;    %Update PH5TIME measurement
        end
    end
end

```

```
end
timer_15=0.0;
end
end
```

%End of Batch Phase Timers

%BATCH PULPER PROCESS SIMULATION

%Phase 1 Simulation

```
if (phase1==1.0)
    flg1=1.0;
    PH_NO_1_5=1.0;    % 'Phase 1 On'

    if (PH6_WATER > 10.0)
        if (WATER_ACCUM < PH1DEMAND)
            if (LT102 > 5.0)
                PULPER_FL=7500.0+9000.0;    %Pulper Filling and Phase 6 Water Being Fed
                PH6_WATER=PH6_WATER-9000.0*TIMESTEP;
            else
                PULPER_FL=FIC101;    %Pulper Head Tank Can't Supply Demand
                PH6_WATER=PH6_WATER-FIC101*TIMESTEP;
            end
        else
            PULPER_FL=9000.0;
            %FT162=FIC101;

        end
    else
        if (WATER_ACCUM < PH1DEMAND)
            if ((LT102 > 5.0))
                PULPER_FL=7500.0;    %Pulper is Filling
            else
                PULPER_FL=FIC101;
            end
        end
    end
    WATER_ACCUM=7500.0*TIMESTEP+WATER_ACCUM;
```

```

end

if (WATER_ACCUM >=PH1DEMAND)

    phase1=0.0;
    if (PH6_WATER < 100)
        PULPER_FL=0.0;    %Shut Off Head Tank Flow When Accumulator Limit is Reached
    end
end

if (BATCH_TIME > 3.0)
    if (flg1==1.0)
        phase2=1.0;
    end
end

%Phase 2 Simulation

if (phase2==1.0)                                %Phase 2 is Running

    flg1=0.0;
    flg2=1.0;
    PH_NO_1_5=2.0;                                %'Phase 2 On'

    PH6_WATER=0.0;

    if (WATER_ACCUM <= (PH1DEMAND+PH2DEMAND))
        if (LT102 >5.0)
            PULPER_FL=2500.0;
        else
            PULPER_FL=2000.0;
        end

    elseif (WATER_ACCUM > (PH1DEMAND+PH2DEMAND))

        PULPER_FL=0.0;                                %Phase 2 Water Supplied

    end
    WATER_ACCUM=PULPER_FL*TIMESTEP+WATER_ACCUM;
end

```

```

if (phase2==1.0)
  if (WATER_ACCUM > (PH1DEMAND+PH2DEMAND))
    phase2=0.0;
    PULPER_FL=0.0;
  end
end

```

```

if (BATCH_TIME > (6.0))
  if (phase2==0.0)
    if (flg2==1.0)
      phase3=1.0;
    end
  end
end

```

%Phase 3 Simulation

```

if (phase3==1.0)
  flg2=0.0;
  PH3TIMER=PH3TIMER+TIMESTEP;
  PH_NO_1_5=3.0;
  PULPER_FL=0.0;
  WATER_ACCUM=PULPER_FL*TIMESTEP+WATER_ACCUM;
  if (PH3TIMER >= PH3SPT)
    phase4=1.0;
    phase3=0.0;
  end
end

```

%Phase 4 Simulation

```

if (phase4==1.0)

  PH_NO_1_5=4.0;                                %'Phase 4 Begins'
  if (WATER_ACCUM < (PH4DEMAND+PH2DEMAND+PH1DEMAND))
    if (LT102 > 5.0)
      PULPER_FL=7785.0;
    end
  end
end

```

```

else
    PULPER_FL=0.5*FIC101;
end
end
if (WATER_ACCUM > (PH4DEMAND+PH2DEMAND+PH1DEMAND))
    PULPER_FL=0.0;           %Phase 4 Discharge Pre-Dilution Complete
    phase5=1.0;             %Okay to Proceed with Phase 5
    phase4=0.0;
end

WATER_ACCUM=PULPER_FL*TIMESTEP+WATER_ACCUM;

end

%Phase 5 Simulation

if (phase5==1.0)
    %'Phase 5 Now On'
    PH5_TIMER=PH5_TIMER+TIMESTEP;
    %Pulper Begins Discharging
    PH_NO_1_5=5.0;

    if ((PH5_TIMER > 0.70))
        %'Discharge Valve OPEN'
        if (PH5_TIMER <= 2.4)
            PULPER_FL= 9000.0;
        end
    end
    if (PH5_TIMER > 2.4)
        PULPER_FL=8000.0+11500.0;
    end
    if (PH5_TIMER > 5.0)
        PULPER_FL = 7500.0+6000.0;
    end

    if (LT102 < 3.0)
        PULPER_FL=FIC101;           %In the Event of Low Pulper Head Tank Level
    end
    WATER_ACCUM=PULPER_FL*TIMESTEP+WATER_ACCUM;

    if (WATER_ACCUM >(PH5DEMAND+PH4DEMAND+PH2DEMAND+PH1DEMAND))

```



```

phase5=0.0;
phase6=1.0;
PH6_WATER=PH6DEMAND;           %Setting Phase 6 Water Demand Once Phase 5 is
                                %Done

PULPER_FL=0.0;
end

```

```
end
```

%Phase 6 (Between Batch if Prolonged Pause Delay Occurs) Simulation

```

if (phase6==1.0)

%'Phase 6 on'
PH_NO_1_5=6.0;
PH5_TIMER=0.0;                 %Reset Phase 5 Timer to Zero
PH1_PAUSE_T=0.0;
PH3TIMER=0.0;

if (PH6_WATER > 5.0)
  PULPER_FL=9000.0;
end
PH6_WATER=PH6_WATER-9000.0*TIMESTEP;   %Drawing Down Phase 6 Water
                                        %Demand

if (PH6_WATER < 5.0)
  PULPER_FL =0.0;               %Shut Off Phase 6 Pulper Flow
  PH6_WATER=0.0;
end
%'Phase 1 is on Pause Until Checked
WATER_ACCUM=0.0;               %Reset the Total Batch Water Accumulation for Next
                                %Batch
PH6_TIMER=PH6_TIMER+TIMESTEP;

```

%Simulate Between Batch Pausing Delays

```

if (pause_test==1.0)
  if (BATCHCOUNT==8)
    PH6_WAIT=2.4;
  end;
  if (BATCHCOUNT==9)
    PH6_WAIT=2.5;
  end;
end;

```

```

end;
if (BATCHCOUNT==10)
  PH6_WAIT=3.0;
end;
if (BATCHCOUNT==11)
  PH6_WAIT=3.5;
end;
if (BATCHCOUNT==12)
  PH6_WAIT=2.5;
end
if (BATCHCOUNT==13)
  PH6_WAIT=0.2;
end
end
if (PH6_TIMER > PH6_WAIT)
  phase6=0.0;
  TIMES(looping,1)=BATCH_TIME;
  looping=looping+1;
  BATCH_TIME_L=BATCH_TIME+TIMESTEP;
  BATCH_TIME_T=BATCH_TIME+TIMESTEP;
  BATCH_TIME=0.0;           %Reset Batch Time for New Cycle
  BEGIN=1.0;
  PH6TIME=PH6_TIMER;
  PH6_TIMER=0.0;
  if (PH6_WATER < 5.0)
    PULPER_FL =0.0;           %Shut Off Phase 6 Pulper Flow
    PH6_WATER=0.0;
  end
  phase1=1.0;           %Return to Phase 1 Start
end
end

```

%-----
%PULPER HEAD TANK FEED FORWARD CONTROL ALGORITHM

```

if (PH_NO_1_5==1)
  if (check1==0.0)
    %Account for Effects of Variations in Batch to Batch Tonnage on Filling Time
    PH2TIME=PH2TIME*(TONNAGE/TONNAGE_L);
  end
end

```

```

    PH4TIME=PH4TIME*(TONNAGE/TONNAGE_L);
    PH5TIME=PH5TIME*(TONNAGE/TONNAGE_L);
    check1=1.0;
  end
end

if (PH_NO_1_5==2)
  check1=0.0;
  check3=0.0;
  testing=0.0;
end

if (PH_NO_1_5==3)
  if (check3==0.0)
    TONNAGE_L=TONNAGE;
    %PHDemand= Adjust Actual Phase 4,5 Water Demands
    %PH5Demand= to Account for Actual Tonnage Added to Pulper
    check3=1.0;
  end
end

if (PH_NO_1_5==4)
  flg_CAP4=0.0;
  flg_LOW4=0.0;
  flg_CAP51=0.0;
  flg_5END=0.0;
end

```

%Phase 1 Feed Forward Control Calculations

```

if (PH_NO_1_5==1)
  count5=0.0;
  if (testing==0.0)
    testing=1.0;
    FIC_loop1=FIC101;

    FIC_MEAN= (PH1DEMAND+PH2DEMAND+PH4DEMAND+PH5DEMAND+
              PH6DEMAND)/BATCH_TIME_L;

    CAP4= (LT102/100.0*VHDTK-PH1DEMAND-PH6_WATER-PH2DEMAND+
           FIC_loop1*(PH1TIME+PH2TIME+PH3TIME))/VHDTK;
  end
end

```

```

if (CAP4 > MAX_LEVEL)

    FIC_CAP4= (MAX_LEVEL*VHDTK-LT102/100.0*VHDTK+PH1DEMAND+
              PH6_WATER+PH2DEMAND)/(PH1TIME+PH2TIME+PH3TIME);
    flg_CAP4=1.0;

end

CAP4_L=      (LT102/100.0*VHDTK-PH1DEMAND-PH6_WATER-PH2DEMAND+
              FIC_loop1*(PH1TIME+PH2TIME+PH3TIME))/VHDTK;
if (CAP4_L < 0.65)
    CAP4_L=0.65;

    FIC_LOW4= (CAP4_L*VHDTK-LT102/100.0*VHDTK+PH1DEMAND+PH6_WATER+
              PH2DEMAND)/(PH1TIME+PH2TIME+PH3TIME);
    flg_LOW4=1.0
end

CAP5_1=      (LT102/100.0*VHDTK-PH1DEMAND-PH6_WATER-PH2DEMAND-
              PH4DEMAND+FIC_loop1*(PH1TIME+PH2TIME+PH3TIME+
              PH4TIME))/VHDTK;

if (CAP5_1 > MAX_LEVEL)
    CAP5_1=MAX_LEVEL;

    FIC_CAP51= (CAP5_1*VHDTK-LT102/100.0*VHDTK+PH1DEMAND+
              PH6_WATER+ PH2DEMAND+PH4DEMAND)/(PH1TIME+
              PH2TIME+PH3TIME+PH4TIME);

    flg_CAP51=1.0;
end

if (CAP5_1 < MAX_LEVEL)
    ENDCAP5_1=(CAP5_1*VHDTK-PH5DEMAND+FIC_loop1*PH5TIME)/VHDTK;
end

if (ENDCAP5_1 < MIN_LEVEL)
    FIC_TEST=FIC_loop1;
    while (END5_DONE==0.0),
        FIC_TEST=FIC_TEST+5.0;

```

```

CAP5_1= (LT102/100.0*VHDTK-PH1DEMAND-PH6_WATER-PH2DEMAND-
PH4DEMAND+FIC_TEST*(PH1TIME+PH2TIME+PH3TIME+
PH4TIME))/VHDTK;

if (CAP5_1 < MAX_LEVEL)
  ENDCAP5_1=(CAP5_1*VHDTK-PH5DEMAND+FIC_TEST*PH5TIME)/VHDTK;
end

if (ENDCAP5_1 > MIN_LEVEL)
  ENDS_DONE=1.0;
  FIC_5END=FIC_TEST;
end

if (CAP5_1 > MAX_LEVEL)
  FIC_TEST=FIC_TEST-10.0;
  FIC_5END=FIC_TEST;
  ENDS_DONE=1.0;
end

end                                     %End of Inner While Loop ENDS_DONE
  flg_5END=1.0;

end

if (flg_CAP4 ==1.0)
  if (flg_CAP51 ==0.0)
    FIC_loop1=FIC_CAP4;
  end
end
if (flg_CAP51 ==1.0)
  FIC_loop1=FIC_CAP51;
end
if (flg_LOW4 ==1.0)
  if (flg_5END==0.0)
    if (FIC_loop1 < FIC_LOW4)
      FIC_loop1 = FIC_LOW4;
    end
  end
end
if (flg_5END ==1.0)
  FIC_loop1=FIC_5END;

```

end

FIC101=FIC_loop1;

end
end

%testing loop
%PH_NO_1_5==1

%Phase 2 Feed Forward Control Calculations

```
if (PH_NO_1_5==2)
  if (count2==0.0)
    ENDS_DONE=0.0;                %Flag for Phase 1 Only
    count2=1.0;
    FIC_loop2=FIC101;
    ENDS_2_DONE=0.0;

    while (ENDS_2_DONE==0.0),

      FIC_loop2=FIC_loop2+5.0;

      CAP5_2=      (LT102/100.0*VHDTK-PH2DEMAND-PH4DEMAND+
                   FIC_loop2*(PH2TIME+ PH3TIME+PH4TIME))/VHDTK;

      if (CAP5_2 < MAX_LEVEL)
        ENDCAP5_2=(CAP5_2*VHDTK-PH5DEMAND+FIC_loop2*PH5TIME)/VHDTK;

        if (ENDCAP5_2 > MIN_LEVEL)
          ENDS_2_DONE=1.0;
          FIC_5_2END=FIC_loop2;
        end
      end

      if (CAP5_2 > MAX_LEVEL)
        CAP5_2=MAX_LEVEL;
        FIC_5_2END=      (CAP5_2*VHDTK-LT102/100.0*VHDTK+PH2DEMAND+
                          PH4DEMAND)/(PH2TIME+PH3TIME+PH4TIME);

        flg_CAP52=1.0;
        ENDS_2_DONE=1.0;
      end
    end
  end
end
```

```

    FIC101=FIC_5_2END;
end                                     %End of Phase 2 While Loop

end
end

%Phase 3 Feed Forward Control Calculations

if (PH_NO_1_5==3)
if (count3==0.0)
    count2=0.0;
    ENDS_2_DONE=0.0;
    count3=1.0;
    ENDCAP5_3=      (LT102/100.0*VHDTK-PH4DEMAND-PH5DEMAND+FIC101*
                    (PH3TIME+PH4TIME+PH5TIME))/VHDTK;
    FIC3_TEST=FIC101;
while (ENDS_3_DONE==0.0),
    FIC3_TEST=FIC3_TEST+5.0;

    CAP5_3=      (LT102/100.0*VHDTK-PH4DEMAND+FIC3_TEST*(PH3TIME+
                    PH4TIME))/VHDTK;

    if (CAP5_3 < MAX_LEVEL)
        ENDCAP5_3=(CAP5_3*VHDTK-PH5DEMAND+FIC3_TEST*PH5TIME)/VHDTK;

    if (ENDCAP5_3 > MIN_LEVEL)
        ENDS_3_DONE=1.0;
        FIC_5_3END=FIC3_TEST;
    end
end

    if (CAP5_3 > MAX_LEVEL)
        FIC3_TEST=      (MAX_LEVEL*VHDTK-LT102/100.0*VHDTK+PH4DEMAND)/
                        (PH4TIME+PH3TIME);

        FIC_5_3END=FIC3_TEST;
        ENDS_3_DONE=1.0;
    end
end

end                                     %End of Phase 3 While Loop
    FIC101=FIC3_TEST;

```

end
end

%Phase 4 Feed Forward Control Calculations

```
if (PH_NO_1_5==4)
    if (count4==0.0)
        count4=1.0;
        count3=0.0;
        END_5_3_DONE=0.0;
        END4_DONE=0.0;
        FIC_loop4=FIC101;

        while (END4_DONE==0.0),
            FIC_loop4=FIC_loop4+5.0;
            CAP5_4=(LT102/100.0*VHDTK-PH4DEMAND+FIC_loop4*(PH4TIME))/VHDTK;

            if (CAP5_4 < MAX_LEVEL)
                ENDCAP5_4=(CAP5_4*VHDTK-PH5DEMAND+FIC_loop4*PH5TIME)/VHDTK;
                if (ENDCAP5_4 > MIN_LEVEL)
                    END4_DONE=1.0;
                    FIC_5_4END=FIC_loop4;
                end
            end

            if (CAP5_4 > MAX_LEVEL)
                FIC_loop4= (MAX_LEVEL*VHDTK-LT102/100.0*VHDTK+PH4DEMAND)/
                    (PH4TIME);

                FIC_5_4END=FIC_loop4;
                END4_DONE=1.0;
            end

        end

        end                                     %End of Phase 4 While Loop
        FIC101=FIC_loop4;

    end
end
```

%Phase 5 Feed Forward Control Calculations

```
if (PH_NO_1_5==5)
  if (count5==0.0)
    count4=0.0;
    END4_DONE=0.0;
    count5=1.0;
    ENDPH5_DONE=0.0;

    if (FIC101 < 4000.0)
      FIC_loop5=FIC_MEAN;      %Low Flow Indicates Prior FIC101 Shut-Off to Prevent
                               %Head Tank Overflow
    else
      FIC_loop5=FIC101;
    end
    while (ENDPH5_DONE==0.0),
      FIC_loop5=FIC_loop5+5.0;
      ENDCAP5=(LT102/100.0*VHDTK-PH5DEMAND+FIC_loop5*PH5TIME)/VHDTK;

      if (ENDCAP5 > MIN_LEVEL)
        if (FIC_MEAN > FIC_loop5)
          if (PH6_WAIT < 0.5)
            FIC_loop5=(FIC_MEAN+FIC_loop5)/2.0;
          end
        end
      end
      ENDPH5_DONE=1.0;

    end
  end
  FIC101=FIC_loop5;          %End of Phase 5 While Loop
end
end
```

%Phase 6 Feed Forward Control Calculations

```
if (PH_NO_1_5==6.0)
  if (count6==0.0)
    count6=1.0;
    count5=0.0;
    ENDPH5_DONE=0.0;
    END6_DONE=0.0;
```

```

if (PH6_WAIT > 1.0)
    FIC_loop6=FIC101;
    while (END6_DONE==0.0),
        FIC_loop6=FIC_loop6+5.0;

        CAP5_0= (LT102/100.0*VHDTK-PH6_WATER-PH1DEMAND-PH2DEMAND-
                PH4DEMAND+FIC_loop6*(PH6_WAIT+PH1TIME+ PH2TIME+
                PH3TIME+ PH4TIME))/VHDTK;

        if (CAP5_0 > 0.95)

            FIC_loop6= (0.95*VHDTK-LT102/100.0*VHDTK+PH6_WATER+
                PH1DEMAND+ PH2DEMAND+PH4DEMAND)/(PH6_WAIT+
                PH1TIME+ PH2TIME+PH3TIME+ PH4TIME);

            end
            END6_DONE=1.0;
            end                                %End of Phase 6 While Loop
            FIC101=FIC_loop6;
            end
            end
            end
end

```

%High Level Alert Limits and Response

```

if (LT102 > 97)
    if (high_level==0.0)
        FIC_STORAGE=FIC101;
        end
        FIC101=FIC101/1.4;
        high_level=1.0;
    end
    if (high_level==1.0)
        if (LT102 < 90.0)
            FIC101=FIC_STORAGE;        %Return to Setpoint Flow for Normal Operation
            high_level=0.0;
        end
    end
end

```

%END OF CONTROL ALGORITHM

%-----

%Limit Pulper Head Tank Flow to Maximum Allowable Value

```
if (FIC101 > FIC101_MAX)
  FIC101= FIC101_MAX;
end
```

%Simulate Offset in the FIC101 Setpoint

```
if (flow_offset==1.0)
  DVDT_HDTK=((factor*FIC101)-PULPER_FL);
end
if (flow_offset==0.0)
  DVDT_HDTK=(FIC101-PULPER_FL);
end
```

```
HDTK_VOL=HDTK_VOL+DVDT_HDTK*(TIMESTEP);
LT102=(HDTK_VOL/VHDTK)*100.0;
```

%Display Messages--Define Output

```
OUTPUT=[LT102 FIC101 PULPER_FL WATER_ACCUM];
INT(loops,1)=INT_LEVEL;
LTAV(loops,1)=LT102_AVE1*100;
TONS(loops,1)=TONNAGE;
BAT_TIME(loops,1)=BATCH_TIME_L;
```

%Store Key Variables Every 10 Seconds

```
if (store_time >= ((10/60)))
  LEVEL(store_loop,1)=LT102;
  FLOW(store_loop,1)=FIC101;
  PH(store_loop,1)=PH_NO_1_5;
  BATTON(store_loop,1)=TONNAGE;
  PAUSE(store_loop,1)=PH6_WAIT;
  store_time=0.0;
  store_loop=store_loop+1;
end
store_time=store_time+TIMESTEP;
```

```
A102(loops,1)=LT102;
F101(loops,1)=FIC101;
WAIT(loops,1)=PH6_WAIT;
phase(loops,1)=PH_NO_1_5*1000;
```

```
loops=loops+1;
```

%Control of Display Period

```
if (BATCH_TIME < 0.08)
    DISPLAY_TIME=BATCH_TIME;
end
if (BATCH_TIME > (DISPLAY_TIME+3.0))
    DISPLAY_TIME=BATCH_TIME;
    out= [LT102 PULPER_FL WATER_ACCUM PH_NO_1_5 ]
end
```

```
BATCH_TIME=BATCH_TIME+TIMESTEP;
```

```
end
```

```
%END STATEMENT FOR OUTER WHILE LOOP WHICH EXECUTES ONCE PER  
%TIME STEP
```

```
%-----
```

%Plotting and Display Functions

```
plot(A102*100)
hold on
plot(phase)
plot(F101)
%plot(FAVE)
if (pause_test==1.0)
    plot(WAIT*1000);
end
if (ton_var==1)
    plot(TONS*1000);
end
hold off
```

REFERENCES

- [1] Clark, J., "Pulp Technology and treatment for Paper", Second Edition, Miller Freeman Publications, Inc., San Francisco (1985).
- [2] McKinney, R.W.J., "Wastepaper Preparation and Contaminant Removal", in "Technology of Paper Recycling", R.W.J McKinney, Ed., Blackie Academic & Professional, London, (1995).
- [3] Boegh, K., Head of Special Projects, Avenor Inc., December 1996, Private Communication.
- [4] Renders, A., "Recycling Fibre Bleaching", in "Technology of Paper Recycling". R.W.J. McKinney, Ed., Blackie Academic & Professional, London, (1995).
- [5] Ferguson, L.D., "Deinking Chemistry: Part 1", Tappi Journal, 75(7), 75-78 (1992).
- [6] Francis, R. and Paquet, R., "Deinking of Fresh and Aged ONP/OMG Papers: Study of Variables in Pulper Chemistry and Operation-Progress Report", Dupont Canada Inc., March 1997.
- [7] Ali, T., McLellan, J., Adiwinata, J., May, M., and Evans, T., "Functional and Performance Characteristics of Soluble Silicates in Deinking. Part I: Alkaline Deinking of Newsprint/Magazine", in "1st Research Forum on Recycling", Toronto, ON, Canada, Oct. 29-31, 1991.
- [8] Boegh, K., Head of Special Projects, Avenor Inc., January 1997, Private Communication.
- [9] Turvey, R.W., "Chemical Use in Recycling", in "Technology of Paper Recycling", R.W.J McKinney, Ed., Blackie Academic & Professional, London, (1995).
- [10] Ferguson, L., "Deinking Chemistry: Part 2", Tappi Journal, 75(8), 52 (1992).
- [11] Larsson, A., Stenius, P. and Odberg, L., "Surface Chemistry in Flotation Deinking", Svensk Papperstidning, 18, R158-R163 (1984).
- [12] Mak, N. and Stevens, J., "Characteristics of Fatty Acid as an Effective Flotation Deinking Collector", in "2nd Research Forum on Recycling", Ste-Adele, QC, Canada, Oct. 5-7, 1993.
- [13] Putz, H.J., Schaffrath, H.J. and Gottsching, L., "Deinking of Oil And Water-Borne Printing Inks: A New Flotation Model", in "1st Research Forum on Recycling", Toronto, ON, Canada, Oct. 29-31, 1991.
- [14] Putz, H.J., Schaffrath, H.J. and Gottsching, L., "Deinking of Oil And Water-Borne Printing Inks: A New Flotation Model", Pulp & Paper Canada, 94(7), 1993.
- [15] Turvey, R.W., "Why do Fibers Float?", in "1st Recycling Forum", Technical Section CPPA.

1991.

- [16] Paulsen, F.G., Pan, R., Bousfield, D.W., Thompson, E.V., "The Dynamics of Bubble/Particle Approach And Attachment During Flotation And The Influence Of Short-Range Nonhydrodynamic Forces On Film Rupture", in "2nd Research Forum on Recycling", Ste-Adele, QC, Canada, Oct. 5-7, 1993.
- [17] Boegh, K., Head of Special Projects, Avenor Inc., March 1998, Private Communication.
- [18] Schulze, H., "The Fundamentals of Flotation Deinking in Comparison to Mineral Flotation", in "1st Research Forum on Recycling", Toronto, ON, Canada, Oct. 29-31, 1991.
- [19] Fogarty, T.J., "Cost-effective, Common Sense Approach to Stickies Control", Tappi Journal, 76(3), (1993).
- [20] McKinney, R.W.J., "Water and Waste Water Treatment in Recycling Mills", in "Technology of Paper Recycling", R.W.J McKinney, Ed., Blackie Academic & Professional, London, (1995).
- [21] Oye, R., Okayama, T., Yamazaki, Y. and Yoshinaga, N., "Changes of Pulp Fibre Cell Wall by Recycling", in "1st Research Forum on Recycling", Toronto, ON, Canada, Oct. 29-31, 1991.
- [22] Howard, R.C., "Effects of Recycling on Pulp Quality", in "Technology of Paper Recycling", R.W.J McKinney, Ed., Blackie Academic & Professional, London, (1995).
- [23] Gratton, M.F., "The Recycling Potential Of Calendered Newsprint Fibres", in "1st Research Forum on Recycling", Toronto, ON, Canada, Oct. 29-31, 1991.
- [24] Box, G.E.P., Hunter, W.G and Hunter, J. S., "Statistics for Experimenters", John Wiley and Sons, Inc., New York, NY, (1978).
- [26] Boegh, K., Head of Special Projects, Avenor Inc., March 1997, Private Communication.
- [27] Boegh, K., Head of Special Projects, Avenor Inc., May 1997, Private Communication.
- [28] Boegh, K., Head of Special Projects, Avenor Inc., August 1997, Private Communication.
- [29] Boegh, K., Head of Special Projects, Avenor Inc., June 1997, Private Communication.
- [30] L'Italien, Y., Avenor Inc., June 1997, Private Communication.
- [31] Boegh, K., Head of Special Projects, Avenor Inc., June 1998, Private Communication.

[32] Schriver, K.E., "Mill Chemistry Must Be Considered Before Making Deink Line Decision", in "Paper Recycling", K.L. Patrick, Ed., Miller Freeman Publications, Inc., San Francisco, (1991).

[33] Shinskey, F.G., "Process Control Systems", Fourth Edition, The McGraw Hill Companies, Inc., New York, (1996).

[34] Schaeffer, R.L., McClave, J.T., "Probability and Statistics for Engineers", Third Edition, PWS-KENT Publishing Company, Boston, (1990).